

MOTAK

Project Name: _____

Location: _____

Item #: _____

Qty: _____

MoTak Narrow Depth Kegerator/Beer Dispenser with Double Tap Tower, in Black

MRDD-2S-2



Designed to take up less space than a standard kegerator, the MoTak Narrow Depth Kegerator/Beer Dispenser with Double Tap Tower is an easy way to offer up cold and refreshing draft beers to your patrons. Ideal for work areas with limited space, this narrow depth beer dispenser features one stainless steel tap tower with two taps that allow you to fill pint glasses and pitchers straight from the keg. The unit has a storage capacity of 11.8 cubic feet and holds two half barrel kegs.

FEATURES AND CONSTRUCTION

- Features 1 stainless steel tap tower with 2 taps that allows you to fill pint glasses and pitchers straight from the keg
- Holds 2 half barrel kegs
- 2 solid black locking doors with recessed handles conceal the contents inside and keep them secure after hours
- Includes 2 adjustable plastic coated wire shelves for additional storage of bottles and cans
- Narrow 24" depth is great for work areas with limited space
- Heavy-duty, wear resistant laminated black vinyl front and sides
- All stainless steel countertop, tap towers and drip trays
- Interior features all stainless steel floor and inner walls
- 3" diameter stainless steel insulated beer column
- Side mounted compressor optimizes interior space

ELECTRIC

115V / 60Hz / 1Ph

Cord Length (Inches): 110.20"

Plug Type: NEMA 5-15P

Cord set included

NEMA 5-15P



3RD PARTY APPROVALS



Intertek



Intertek

WARRANTY (USA / CANADA)

STORAGE CAPACITY

- Cubic Feet: 11.8 cu.ft.
- Half Barrel Keg: 2
- 12 oz Cans: 48 6-pks
- 12 oz Bottles: 60 6-pks

TEMPERATURE

- Holding Temperature (Fahrenheit): 33° - 40°

These models are designed to operate in an environment where temperature and humidity do not exceed 75°F (24°C) and 55% relative humidity

For warranty and non-warranty related issues and technical support call 1-877-368-2797



MoTak Narrow Depth Kegerator/Beer Dispenser with Double Tap Tower

MRDD-2S-2

FRONT

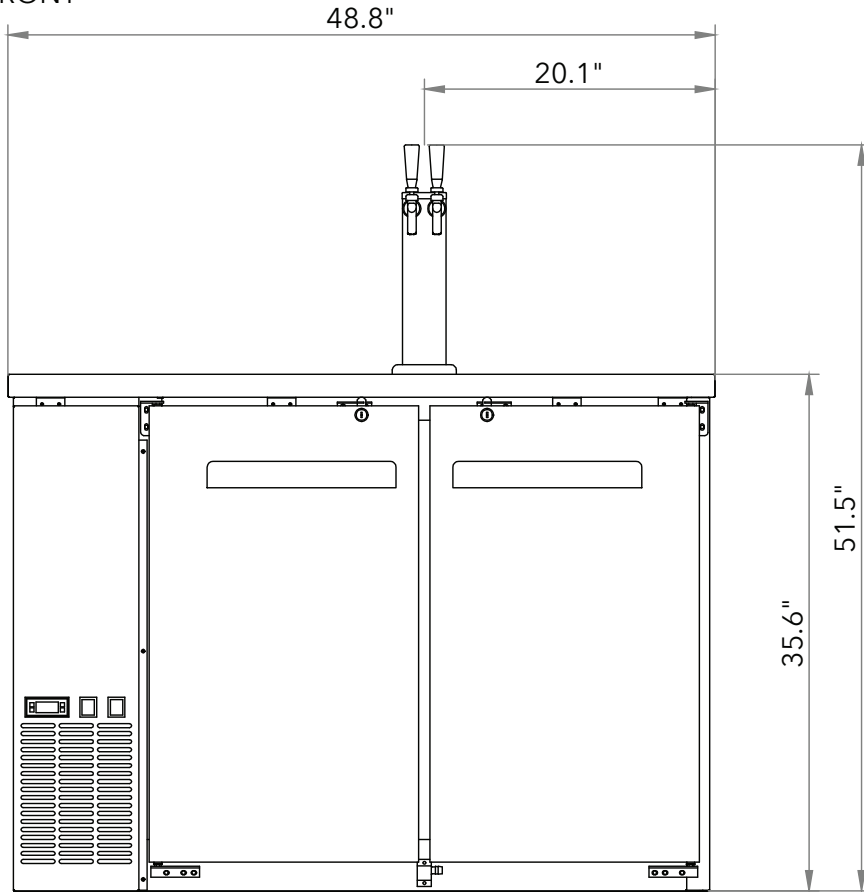

SIDE

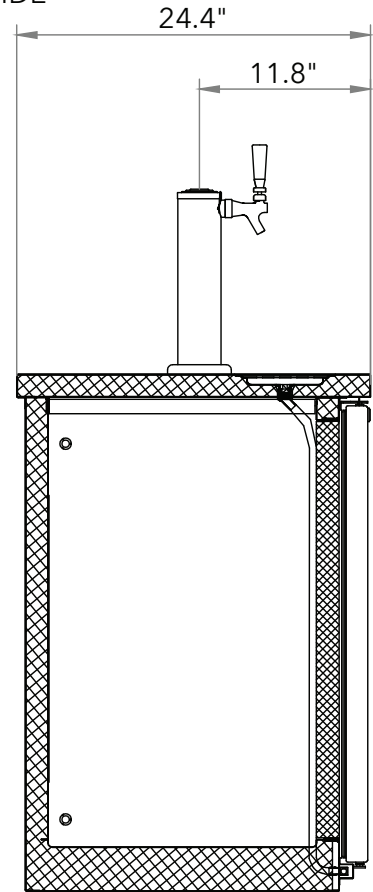

TOP

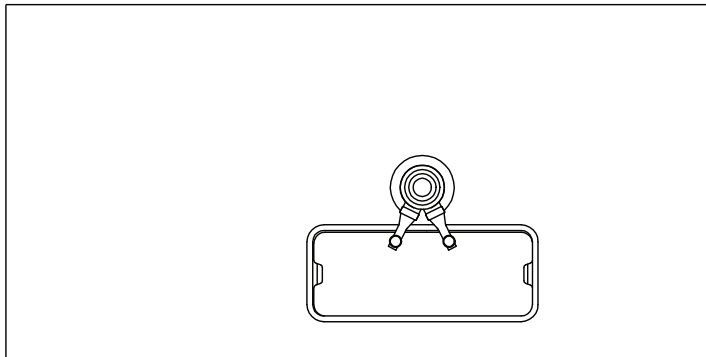

Beer Dispenser

Taps	Kegs (Half Barrels)	Doors	Shelves	Amps	HP	Refrigerant Type / Ounces	Assembled Dimensions (in)	Item Weight (lbs)	Shipping Weight (lbs)
2	2	2	2	3.5A	1/3	R290 / 2.469	24.40" x 48.80" x 35.6"	253.5	280.0

Due to periodic changes in designs, methods, procedures, policies and regulations, the specifications contained in this document are subject to change without notice. While we exercise good faith efforts to provide information that is accurate, we are not responsible for errors or omissions in information provided or conclusions reached as a result of using the specifications. By using the information provided, the user assumes all risks in connection with such use.