

MOTAK

Project Name: _____

Location: _____

Item #: _____

Qty: _____

MoTak Straight Glass Refrigerated Bakery Case, 60"W, 25.3 sq ft Capacity, in Stainless Steel/Black

MCDC-59-2



Designed to showcase and preserve baked goods at a chilled temperature, the MoTak Straight Glass Refrigerated Bakery Case offers a modern, attractive look that's ideal for cafes, bakeries, coffee shops, and more. Present cakes, pies, and pastries while keeping them perfectly chilled with this commercial bakery display case. Designed with a clean, modern aesthetic, this refrigerated bakery case features a sleek glass front that offers customers a clear, enticing view of your signature baked goods. The unit offers a capacity of 25.3 sq ft and comes with three shelves for organization.

FEATURES AND CONSTRUCTION

- Offers 25.3 sq ft capacity for showcasing baked goods while keeping them fresh and organized
- Equipped with a powerful compressor for efficient cooling
- Constructed of polished stainless steel and glass
- Temperature range from 36° to 43°F ensures freshness of desserts
- Utilizes R290 refrigerant for an eco-friendly operation
- Operates on 115V with a NEMA-5-15P plug for standard electrical connections
- Includes 3 shelves to organize pastries, cakes, breads, desserts, and more
- Equipped with 4 casters for mobility
- Integrated locks provide added security for stored items

ELECTRIC

115 V / 60Hz / 1Ph
Cord Length (Inches): 98
Plug Type: NEMA 5-15P
Cord set included

NEMA 5-15P



3RD PARTY APPROVALS



WARRANTY (USA / CANADA)

STORAGE CAPACITY

- 25.3 Sq ft

TEMPERATURE

- Holding Temperature (Fahrenheit): 36 - 43

These models are designed to operate in an environment where temperature and humidity do not exceed 75°F (24°C) and 55% relative humidity

MOTAK MoTak Straight Glass Refrigerated Bakery Case

MCDC-59-2

FRONT

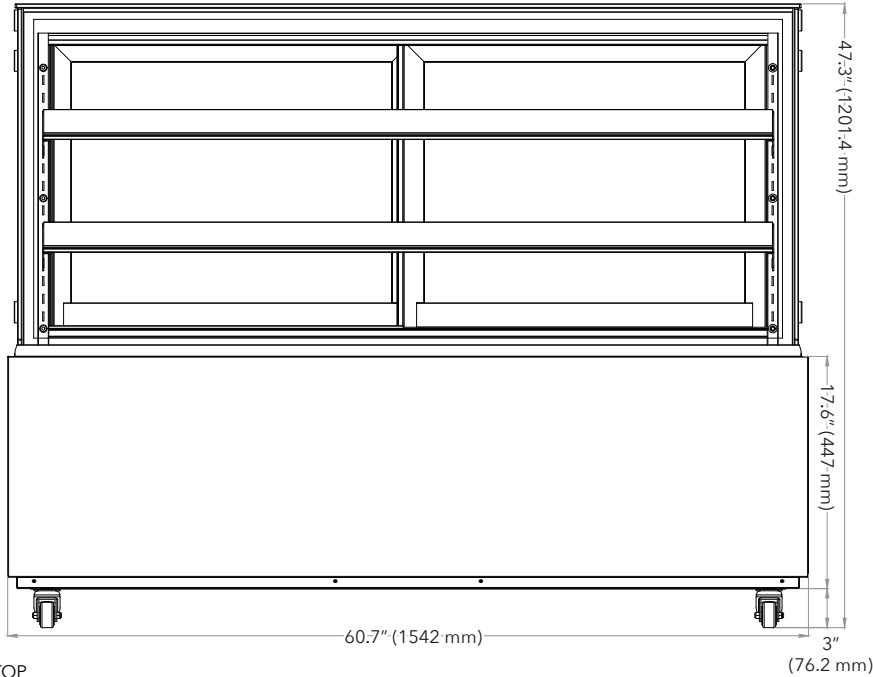

SIDE

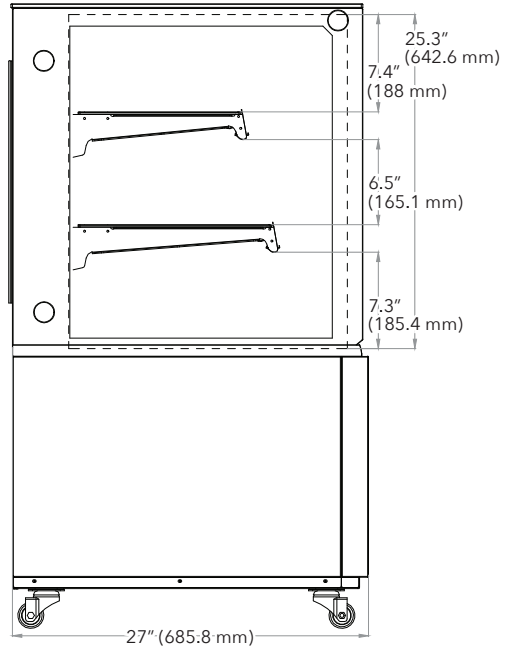

TOP

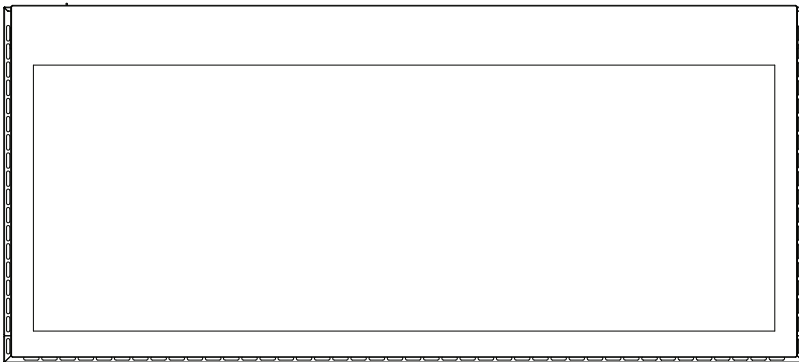

Cake Displays

Doors	Shelves	Amps	Capacity	Refrigerant Type	Assembled Dimensions (in)	Item Weight lbs	Shipping Weight lbs
2	3	8.4	25.3 Sq ft	R290	27.00" x 60.70" x 47.30"	190.0	507.0

Due to periodic changes in designs, methods, procedures, policies and regulations, the specifications contained in this document are subject to change without notice. While we exercise good faith efforts to provide information that is accurate, we are not responsible for errors or omissions in information provided or conclusions reached as a result of using the specifications. By using the information provided, the user assumes all risks in connection with such use.