

COMMERCIAL GAS RANGE

MOTAK



6 BURNERS - STAINLESS STEEL - MANUAL CONTROLS



Natural Gas



Liquid Propane

PRODUCT FEATURES

- 36" wide
- Natural gas (LP conversion kit included)
- (6) 30,000 BTU cast iron burners
- 12" x 12" removable grates
- Manual rangetop controls
- Full size 32,000-BTU convection oven
- Thermostatic oven control (250°F to 550°F)
- Removable crumb tray
- 24 $\frac{3}{4}$ "H back riser with shelf
- Stainless steel front
- (4) 4" swivel casters (2 with locks)

NOT SUITABLE FOR INSTALLATION IN NON-COMMERCIAL OR RESIDENTIAL APPLICATIONS.



PLAN VIEW

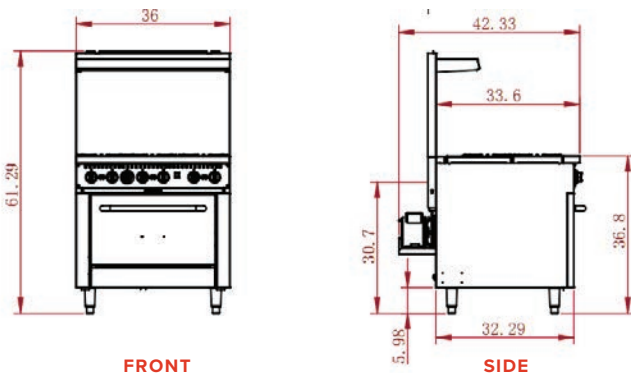

SPECIFICATIONS

MODEL	DIMENSION (WxDxH in inches)	OVEN SIZE (WxDxH in inches)	BTU (PER BURNER)	BTU (PER OVEN)	TEMPERATURE RANGE	BURNERS
MRC36	36 x 42.33 x 61.29	26.8 x 26.1 x 14	30,000	32,000	250-500°F	6

MoTak reserves the right to make changes to the design or specifications without prior notice.