



152 lb Undercounter Slab Ice Machine - Full Dice

MPN: KT-UIH-150-A

Special Features

- Stainless steel, black trim exterior
- Air-cooled compressor
- Programmable, user-friendly digital controls
- Digitally displays ice machine status
- Automatic cleaning cycle and bin overflow prevention
- Internal blue LED light
- 6" adjustable leveling legs
- Ice scoop included with internal scoop holder
- Energy Star approved
- Antimicrobial agent within polyethylene storage bin liner for improved sanitation

Specifications

Model	MI150H
Dimensions	24" x 24" x 39"
Daily Ice Production	152 lbs
Ice Bin Storage Capacity	75 lbs
Amp Draw	5.2A / 6.4A
Refrigerant / Charge Size	R290 (Hydrocarbon)
Electrical	115V / 60Hz / 1Ph

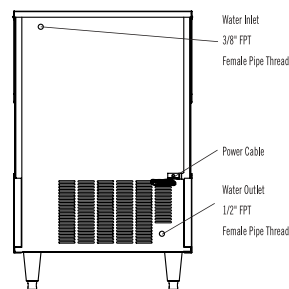
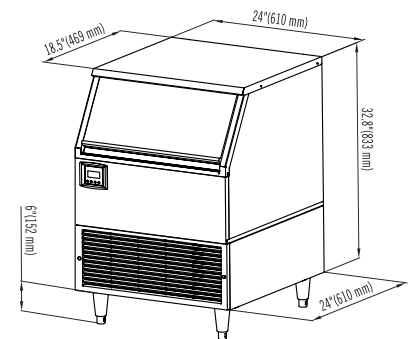
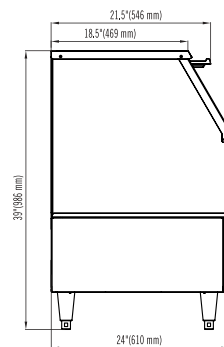

MOTAK reserves the right to make changes to the design or specifications without prior notice.