

Item No.:

Qty.:

Project:

EASYFRESH® NEXT XS



The propane EasyFresh® Next blast chiller can be customised based on individual needs and includes up to 8 functions and 14 cycles chosen for you by Irinox to preserve the freshness of the products for longer. Easy to use, it allows the parameters of each cycle - temperatures, times and ventilation - to be changed in a few simple steps.

Yield

Blast chilling (194°F/37°F) within 90 min 22 lb

Shock freezing (197°F/0°F) within 240 min 22 lb

*Tests carried out in compliance with the Irinox procedure using 2" thick beef.

Capacity

Number of trays: 3 18"x13" sheet pans

3 12"x20" steam table pans

Standard construction details

- Self-contained, air-cooled, energy efficient condensing unit, with R290 refrigerant gas in sealed system.
- Indirect air distribution and special airflow pattern to ensure perfect temperature uniformity.
- Door hinged Left.
- 4" stainless steel adjustable feet.
- Single point core temperature probe.
- One (1) stainless steel wire shelf 12 51/64" x 20 55/64".
- Front mounted USB Data port for data transfer to HACCP software.

Certification



Item No.:

Qty.:

Project:

Operation

Essential. This is the basic configuration that includes the most popular blast chiller functions: chilling, freezing, non-stop, cold holding and defrosting. Regardless of the temperature at which the product is introduced, it always guarantees excellent results in terms of quality and temperature uniformity inside the cell.

- EasyFresh® Next's chilling cycles lower to 37°F the core temperature of the food, introduced at any temperature, even as soon as it is out of the oven, and quickly cross the band of maximum bacterial proliferation, the cause of its natural ageing.
- The EasyFresh® Next's freezing cycles transform the water contained in food into microcrystals that preserve its structure and quality for longer.
- At the start of the cycle, the operator can choose whether to use the core probe (automatic mode) or to work in time mode (manual mode).
- The non-stop cycles continuously chill or freeze to the desired temperature quantities of food that are prepared and placed in the blast chiller in succession. Set a notification when the chosen temperature or cycle time is reached.
- The cold holding cycles allow the blast chiller to be transformed into an additional space for storage at the desired temperature for short periods of time.
- The defrost cycle removes ice and excess condensation. It has an adjustable duration of 30 minutes and must be run at the end of the day or after intensive use with a high number of door openings.

Performance

EasyFresh® Next guarantees a chilling and freezing capacity of 22 lb, thanks to the new propane refrigeration system.

In the Essential configuration, performance is ensured by a propane single circuit with reciprocating compressor, ventilated evaporator and single-speed condenser fan.

Thanks to its climate class 5 design, the blast chiller guarantees the stated performance up to an ambient temperature of 104 °F.

Interface

4.3" display with capacitive colour screen. With acoustic signal with adjustable intensity and fixed tone.

The operator has the possibility of customizing and/or creating new cycles, which are stored in the library.

Connectivity

FreshCloud® is Irinox's IOT technology that allows to control and interact with EasyFresh® Next at any time via an APP.

The functions included in the application are:

- Remote monitoring of the cycle in progress: connection status, cell temperature, core temperature, kitchen and machine name, cycle ID in progress, cycle and phase progress.
- Remote parameter modification (ventilation, cabinet temperature, core probe temperature, phase duration, cycle management).
- Machine status monitoring: connection status, machine ID, laboratory name, serial number, door status.
- Usage statistics viewing.
- Haccp report download.
- Software update.

Optional

- Locking castors with brake (2 with brake and 2 without).
- Extra Wire Shelf 12 51/64" x 20 55/64".
- Low Profile Legs – Height 2" 3/8 - 3" 5/32.

Product warranty

12 months from the date of receipt of the equipment; 24 months from the date of installation, subject to completion and submission of the installation report on FreshCloud®. For more details, see the sales conditions available at www.irinoxprofessional.com.

EASYFRESH® NEXT XS

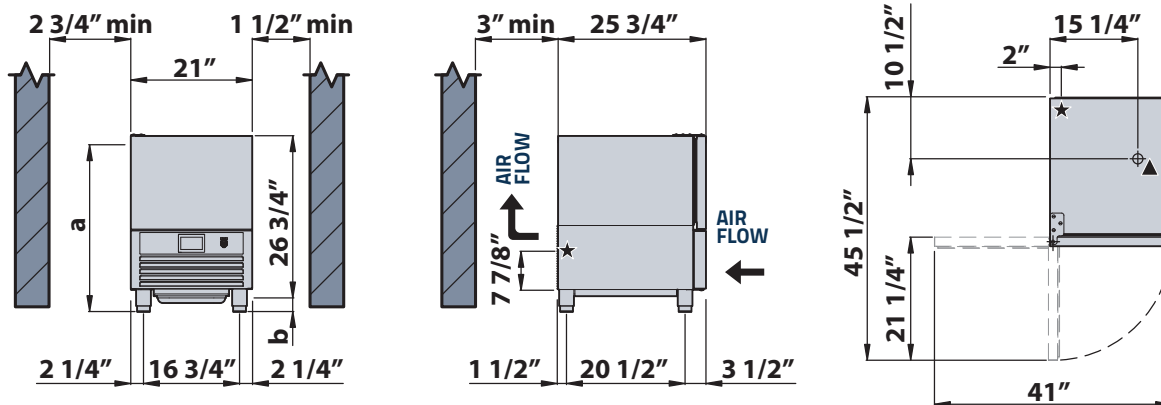

HEIGHT

		HEIGHT (a)	FEET RANGE (b)
Standard feet	in	30" 5/7 - 32" 5/64	4" + 5" 1/3
Castors option	in	30" 1/4	3" 3/7

★ Main power cable

▲ Water drainage (corrugated hose Ø32mm)

TECHNICAL DATA

Electric supply:	-	115V 1N+PE 60Hz	
Performance		ESSENTIAL	
Power rating	W	763	
Total Amps	A	7.7	
Minimum circuit amps (MCA)	A	10	
Max overcurrent protection device (MOPD)	A	20	
Rated load amps (RLA)	A	40	
Main power cable	AWG	3AWG14	
Refrigeration yield (-10/+40°C; Tsuct +20°C; Subcooling OK)	btu/h	4263	
Condenser rating (-10/+40°C; Tsuct+20°C; Subcooling OK)	btu/h	6309	
MIN air flow for ventilation	ft³/h	14124	
Refrigerant type	oz	R290 - 5.29 oz	
Min/max installation ambient temperature	°F	59 / 104	
Max installation elevation	ft	6560	
Internal cell dimension (WIDTH x DEPTH x HEIGHT)	in	12" 7/8 x 21" 5/8 x 12"	
Cabinet weight	Lb	159	

INSTALLATION

The blast chiller must be installed following and complying with what is stated in the appropriate installation manual. The contents of the manual must be carefully followed to ensure correct operation and to protect the user's rights under the warranty. Continuous product development may require changes to specifications without notice.

Irinnox North America Inc.

9990 NW 14th Street, Suite 107 - Miami, FL 33172 USA

Tel.: 786.870.5064 | customersupport@irinnoxnorthamerica.com | www.irinnoxprofessional.com/usa/