



DIGITAL HOT WATER DISPENSER

MODEL: WB5GT63000, WB5GT19000, WB5GT30000



WB5GT63000

5.0 Gallon Hot Water Dispenser

The Curtis G3 Hot Water Dispenser – Perfect for tea, soup, freeze-dried products, cleaning jobs and more!

With the latest in digital technology, these water boilers offer precise control over all critical functions. Curtis' digital Hot Water Dispensers deliver large volumes of piping hot water right at the preparation site. They are constructed of heavy gauge stainless steel and feature thermostatic controls and solid-state automatic refill systems.

ITEM NO

PROJECT

DATE

FEATURES AT A GLANCE

- **G3 Digital Control Module** – Provides precise control of temperature and aeration.
- **Agitation Pump** – Continuous or on demand aeration improves tea extraction and food flavor.
- **Large LED Display** – Easy to read, displays constant water dispense temperature.
- **Easy-To-Operate** – Simple graphic design with color coded buttons for all operating functions and ready lights.
- **Automatic Refill System**
- **Thermostatic Controls** – Programmable temperature range of 140°F to 210°F.
- **On Board Diagnostics** – Continually senses water level & temperature for proper operation.
- **Common Parts and Side Access** – Creates an easy to service unit.
- **Standard 120/220VAC Dual Voltage Operation.**

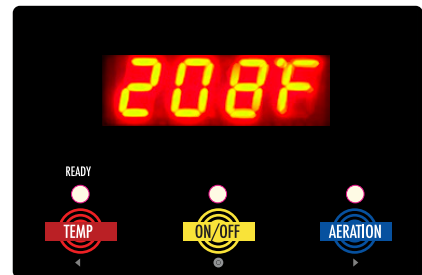

Large LED Display - 140°F - 210°F

WB5GT63000
WB5GT19000
WB5GT30000

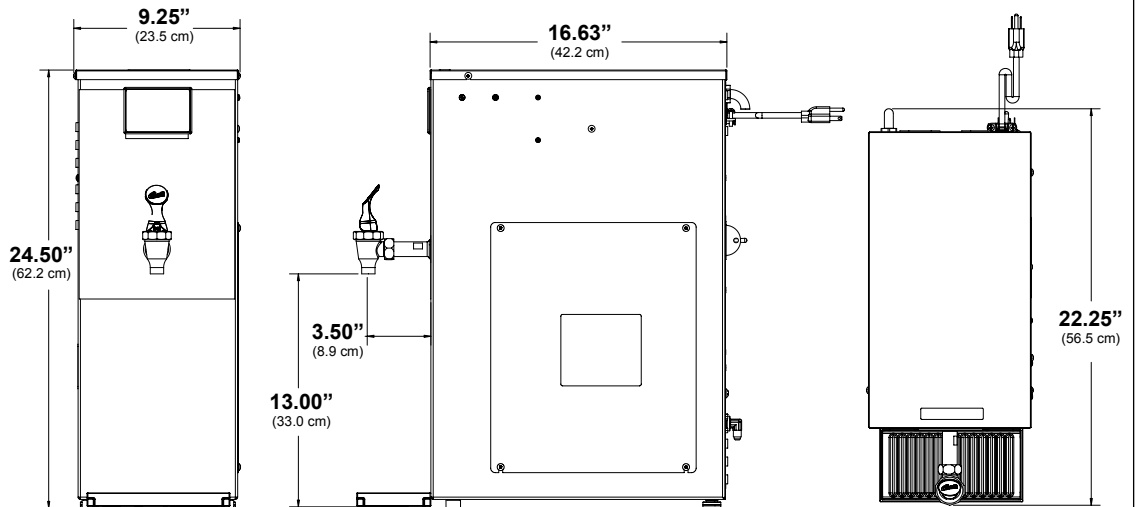

DISPENSER SPECIFICATIONS

MODEL #	DIMENSIONS H x W x D	PHASE	VOLTS	AMPS	WIRE	WATTS	HERTZ	GAL/HR	WATER CONNECT	SHIP WEIGHT	SHIP CUBE
WB5GT63000	24.50" x 9.25" x 22.00"	1 PH	120/220V	12.5/22.7A	2/3W+G	1500/5000W	50/60 Hz	4.5/15.0	1/4" Flare	39.0 lbs.	5.73 cu. ft.
WB5GT19000	24.50" x 9.25" x 22.00"	3 PH	220V	19.7A	4W+G	7500W	50/60 Hz	21.5	1/4" Flare	39.0 lbs.	5.73 cu. ft.
WB5GT30000	24.50" x 9.25" x 22.00"	1 PH	220V	22.7A	2W+G	5000W	50/60 Hz	15.0	1/4" Flare	39.0 lbs.	5.73 cu. ft.

SPECIFICATIONS SUBJECT TO CHANGE WITHOUT NOTICE.



WARNING - These products can expose you to chemicals including Acrylamide and Bisphenol A (BPA), which are known to the State of California to cause cancer and birth defects or other reproductive harm. For more information visit www.P65Warnings.ca.gov



WILBUR CURTIS CO., INC.
 6913 Acco Street, Montebello, CA 90640-5403
 Telephone: 800-421-6150 · 323-837-2300
 Technical Support: 800-995-0417 M-F 5:30am-4:00pm PST
 Fax: 323-837-2406
www.wilburcurtis.com



AUG/2018 - F-3561 revF