



Digital Interlocking Coffee Grinder



READ AND SAVE THESE INSTRUCTIONS

NOTICE TO INSTALLER: Please leave this booklet with the machine.

KEY FEATURES/SPECIFICATIONS/SYSTEM REQUIREMENTS FS115

IMPORTANT SAFEGUARDS..... IS3

INSTALLATION INSTRUCTIONSII63

OPERATING INSTRUCTIONSOI69

CLEANING INSTRUCTIONS CI22

PROGRAMMING GUIDE PG40

ROUGH-IN DRAWING RD124

ILLUSTRATED PARTS LIST (MAIN CHASIS)..... IP209

ILLUSTRATED PARTS LIST (MOTOR)..... IP210

ELECTRICAL SCHEMATICS.....ES165

TROUBLESHOOTING GUIDE (GENERAL)TG55

TROUBLESHOOTING GUIDE (GRINDER ADJUSTMENT).....TG29

PRODUCT WARRANTYPW1

Contact Information

Wilbur Curtis Co., Inc.

6913 Acco Street | Montebello, CA 90640 US
 Phone: 323-837-2300 | Toll Free: 800-421-6150
 Email: cstrassistance@wilburcurtis.com | Web: www.wilburcurtis.com

For the latest specifications and information go to www.wilburcurtis.com
 Toll Free: 800-995-0417 | Monday - Friday 5:30 A.M. - 4:00 P.M. PT
 Email: techsupport@wilburcurtis.com

Due to continued product improvement, the products illustrated/photographed in this guide may vary slightly from the actual product.

Key Features & Specifications

Key Features

- Easy to Use - Fully automatic operation.
- Large Grinding Burrs - Provide faster; more efficient operation.
- Highly Accurate and Consistent Throw - For even distribution, dust reduction.
- Constant, uniform grind.
- Powerful 1/2 hp Motor - Equipped with safety circuit breaker.

Specifications (Selected Models)

Electrical Supply Requirements

MODEL #	DESCRIPTION	PHASE	VOLTS	AMPS	WIRE	WATTS	HERTZ
ILGD-10	Coffee Grinder Single	1 PH	120 V	8.0 A	2W + G	960 W	50/60 Hz

Dimensions

MODEL #	HEIGHT	WIDTH	DEPTH	SHIP WEIGHT	SHIP CUBE
ILGD-10	29.50" [74.9 cm]	10.00" [25.4 cm]	14.50" [36.8 cm]	62.00 lbs [28.1 kg]	5.90 cu. ft. [0.17 m ³]

Important Safeguards & Conventions



This is the safety alert symbol. It is used to alert you to potential physical injury hazards. Obey all safety messages that follow this symbol to avoid possible injury or death.



DANGER - Indicates a hazardous situation which, if not avoided, will result in death or serious injury.



WARNING - Indicates a hazardous situation which, if not avoided, could result in death or serious injury.



CAUTION - Indicates a hazardous situation which, if not avoided, could result in minor or moderate injury.



NOTICE - Indicates a situation which, if not avoided, could result in property damage.



IMPORTANT - Provides information and tips for proper operation.



SANITATION REQUIREMENTS



WARNING - This product can expose you to chemicals including Acrylamide and Bisphenol A (BPA), which are known to the State of California to cause cancer and birth defects or other reproductive harm. For more information visit www.P65Warnings.ca.gov.



WARNING:

- Make sure that this appliance is installed and grounded according to the INSTALLATION INSTRUCTIONS by qualified personnel before attempting to use it. Failure to follow the INSTALLATION INSTRUCTIONS could result in personal injury or void the warranty.
- This appliance is designed for commercial use. Any service other than cleaning and preventive maintenance should be performed by an authorized Wilbur Curtis service technician.
- To reduce the risk of fire or electric shock, DO NOT open the service panels. There are no user serviceable parts inside.
- Clean the appliance completely before using it for the first time, according to the CLEANING INSTRUCTIONS. Clean it regularly as instructed in the CLEANING INSTRUCTIONS.
- Use this appliance only for its intended use, grinding coffee.
- This appliance is not intended for use by persons (including children) with reduced physical, sensory or mental capabilities or lack of experience and knowledge, unless they have been given supervision or instruction concerning use of the appliance by a person responsible for their safety. Children should be supervised to ensure that they do not play with the appliance.
- Avoid spillage onto the power (mains) connector.

CE Requirements

- This appliance must be installed in locations where it can be overseen by trained personnel.
- For proper operation, this appliance must be installed where the temperature is between 5°C to 35°C.
- This appliance is not suitable for outdoor use.
- Appliance shall not be tilted more than 10° for safe operation.
- An electrician must provide electrical service as specified in conformance with all local and national codes. For safe use, an all-pole disconnection must be incorporated into the fixed wiring in accordance with the wiring rules outlined in clause 7.12.2 of IEC 60335 for meeting the minimum electrical safety of this standard.
- This appliance must not be cleaned by water jet.
- This appliance can be used by persons aged from 18 years and above if they have been given supervision or instruction concerning use of the appliance in a safe way and if they understand the hazards involved.
- Keep the appliance and its cord out of reach of children aged less than 18 years.
- Appliances can be used by persons 18 years and above with reduced physical, sensory or mental capabilities or lack of experience and knowledge if they have been given supervision or instruction concerning use of the appliance in a safe way and understand the hazards involved.
- Children under the age of 18 years should be supervised to ensure they do not play with the appliance.
- If the power cord is ever damaged, it must be replaced by the manufacturer or authorized service personnel with a special cord available from the manufacturer or its authorized service personnel in order to avoid a hazard.
- Machine must not be immersed for cleaning.
- Cleaning and user maintenance shall not be made by children unless they are older than 18 years and supervised.
- This appliance is intended to be used in household and similar applications such as:
 - staff kitchen areas in shops, offices and other working environments;
 - by clients in hotels, motels and other residential type environments;
 - bed and breakfast type environments.
- This appliance not intended to be used in applications such as:
 - farm houses
- Access to the service areas permitted by Authorized Service personnel only.
- The A-Weighted sound pressure level is below 70 dBA.

Installation Instructions

 **WARNING:** Installation is to be performed only by a qualified installer.

 **WARNING:** Improper electrical connection may result in an electric shock hazard. This grinder must be properly grounded.

 **IMPORTANT:** Observe all governing codes and ordinances.

Installation Requirements

- A secure surface capable of supporting the weight of the appliance.
- For units without an attached cord set: Appropriately sized, UL listed, grounding type power cable to meet the electrical specifications for the appliance. If you have questions about the correct cable size and length, consult a qualified installer. If the appliance will be hard wired to a junction box, the power cable must be long enough so that the unit can be moved for cleaning underneath.
- A grounded electrical connection to an electrical circuit that meets the electrical specifications of the appliance (see **SPECIFICATIONS**). The circuit must be protected by the appropriate sized circuit breaker. If you are not certain that the existing circuit meets the requirements for your unit, consult a licensed electrician.

Leveling

 **WARNING:** Use the leveling legs to level the grinder only. Do not use them to adjust grinder height. Do not extend them higher than necessary.

- 1 Position the unit on a level counter top. Level it left to right and front to back by turning the bottom of the legs.

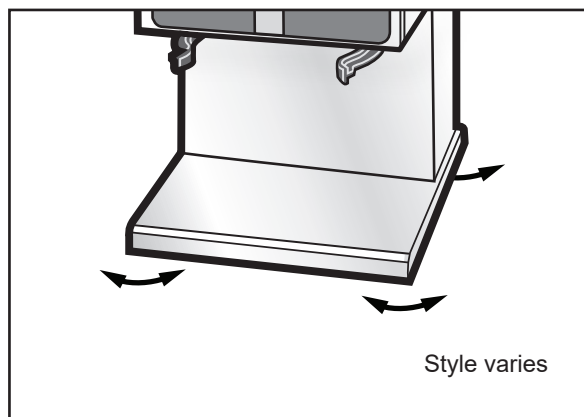

Connecting the Power Plug (units with pre-installed power cord that will be plugged into a power receptacle)

- 2 If not already installed, ensure the appropriate type of receptacle is in place. Consult your local electrical codes to determine the approved power receptacle for your region.

 **NOTICE:** The unit comes with a pre-installed 110V power cord and plug.

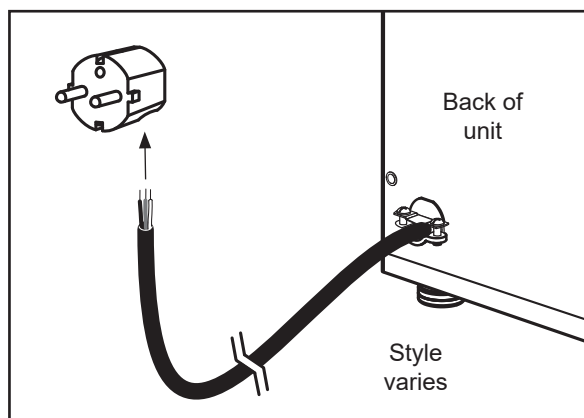

**Connecting the Power Cord to A Junction Box
(units with pre-installed power cord, if applicable)**



WARNING: Turn off power to the junction box at the circuit breaker panel before connecting the power cable. Lock out and tag the circuit breaker.

- 3 If the power cord will be connected directly to the junction box, connect the power cable wires to the terminals in the junction box. See the *ELECTRICAL SCHEMATIC* for the power supply requirements.

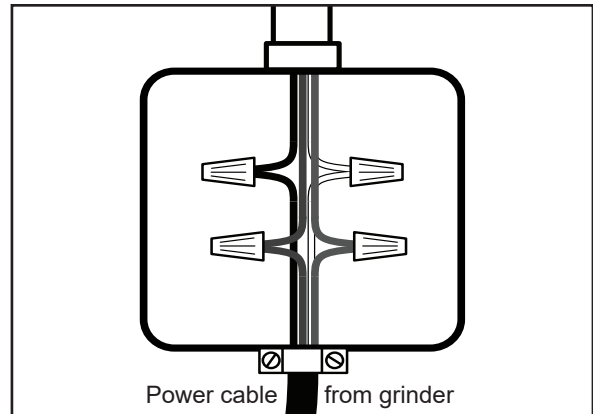

Connect the Power Cable

- 4 On units with a power connector on the back panel, connect a C20 IEC power cord (not supplied) compatible with the electrical outlet installed in the facility and that meets specifications.

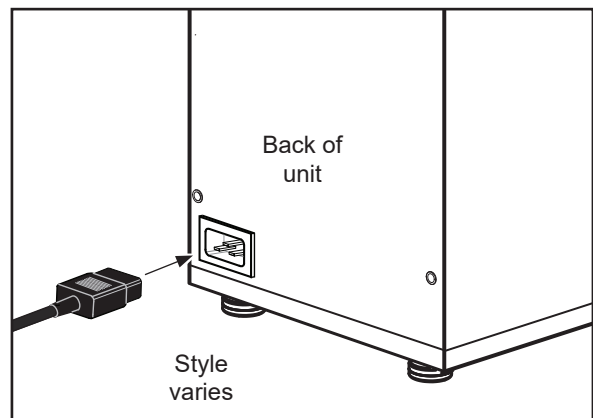

- 5 Connect the power cord to the appropriate type of electrical outlet.



WARNING: Connect the power cord only to the appropriate type and size electrical outlet. If the electrical outlet is not compatible with the power cord, have it upgraded by a licensed electrician. Do not modify the power plug. Do not use an extension cord. Do not use a power cord/plug that is damaged.

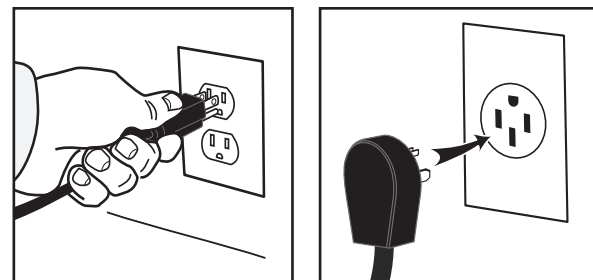

- 6 Turn on the circuit breaker supplying power to the electrical outlet or junction box.

Operating Instructions



WARNING - TO AVOID SCALDING, AVOID SPLASHING. Keep body parts clear of the brewer during brewing. Do not remove the brew basket while the BREW light is on. Keep body parts away from hot surfaces.

The grinder is factory preset for optimal performance.

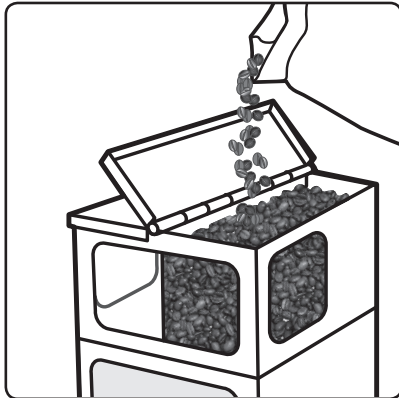

- 1 Open one of the hopper lids and fill with fresh, whole coffee beans.

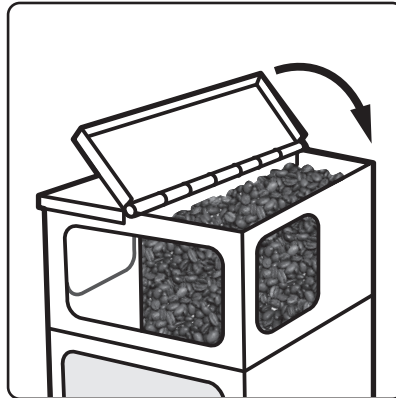

- 2 Close the lid.

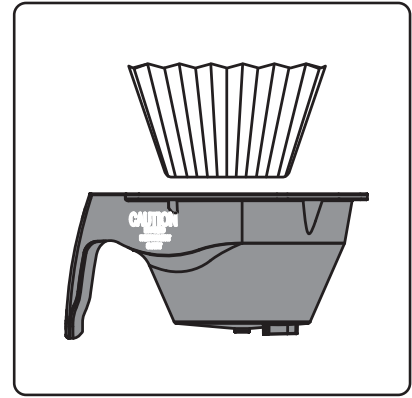

- 3 Place a clean paper filter into the brew basket.

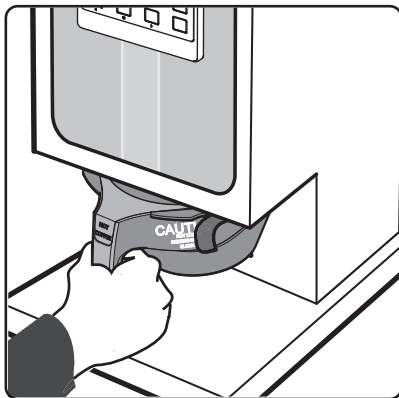

- 4 Slide the brew basket all the way back into the brew basket rails.

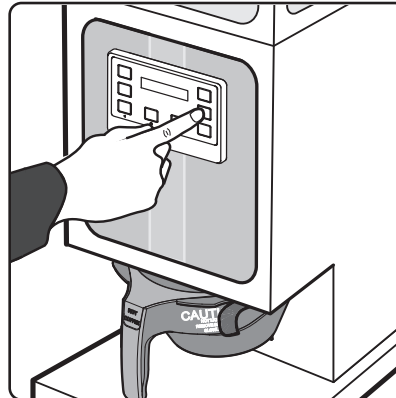

- 5 Make sure the grinder is on. On the grinder control panel, press the desired grind size/ brew volume button; SMALL, MEDIUM or LARGE. The grinder will start to grind coffee into the brew basket. Wait for the grinder motor to stop before removing the brew basket.

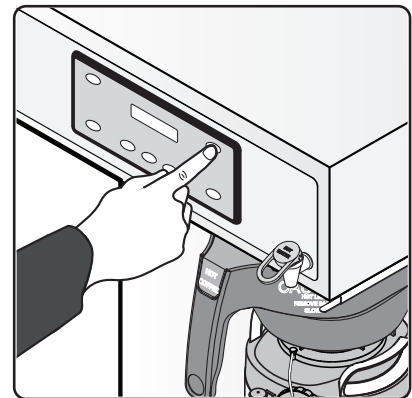

- 6 Some grinders are connected to a brewer and lock the brew selection into the brewer. This is indicated by a flashing LED next to the corresponding BREW button on the brewer. Transfer the filled brew basket to the brewer and press the desired BREW button. The brew cycle is complete when the BREW light stops flashing.

Cleaning Instructions



WARNING: Disconnect the power cord before cleaning.



WARNING: DO NOT immerse the grinder in water or any other liquid. Avoid spilling liquid into the grind housing during cleaning.



NOTICE - Do not use cleaning liquids, compounds or powders containing chlorine (bleach) or corrosives. These products promote corrosion and will damage the finishes. **USE OF THESE PRODUCTS WILL VOID THE WARRANTY.**

The following cleaning process requires a mild solution of dish-washing detergent and warm water, and GRINDZ™ Grinder Cleaner Tablets (Curtis PN WC-79002). The grinder cleaner tablets not only clean the grinder mechanism, but also eliminate the taste and odor left behind when grinding flavored coffee.

- 1 Disconnect the power cord.
- 2 Brush coffee grounds from the dispensing spout. Wipe off the surrounding area.
- 3 Prepare a mild cleaning solution of dish-washing detergent in warm water. Wipe exterior surfaces with a cloth moistened with the cleaning solution.
- 4 Dry the exterior surfaces with a clean soft cloth. Polish exterior stainless steel surfaces with stainless steel polish.
- 5 With the power cord disconnected, remove the coffee beans from the hopper.
- 6 Plug the power cord into the electrical outlet.
- 7 Place an empty container under the grinder chute and run the grinder until all coffee is purged from the housing.
- 8 Pour 2.5 oz. (75 g.) of grinder cleaner tablets into the hopper.
- 9 Run the grinder until all of the cleaner empties from the chute.
- 10 Re-fill the grinder with fresh, whole bean coffee.
- 11 Run the grinder constantly for 35 seconds to purge the residual cleaner from the mechanism.

Programming Guide

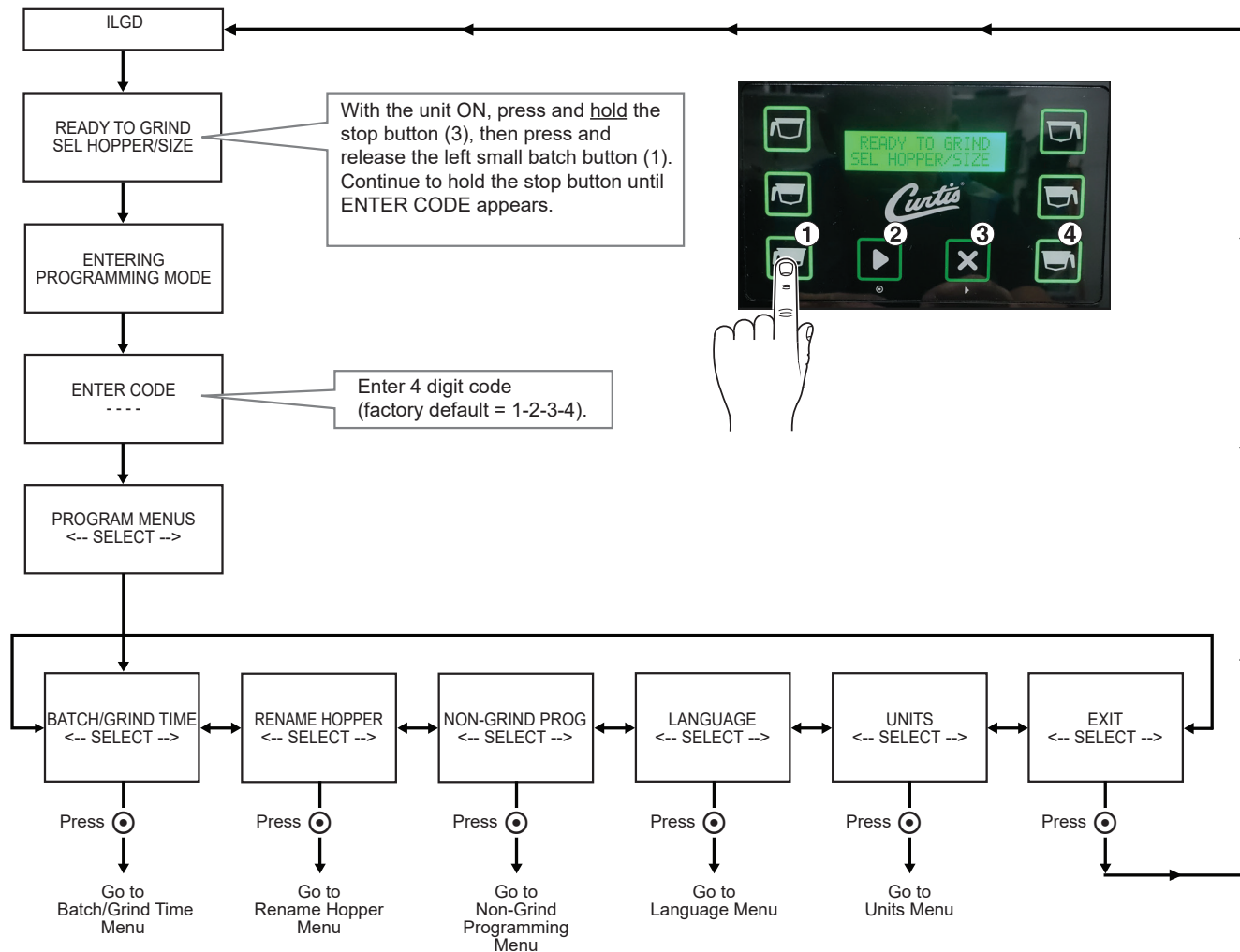

i IMPORTANT: All programming functions are performed with three buttons.

The symbols below the buttons are:

- ◀ Scroll LEFT/UP (1)
- ⊙ SELECT or ENTER to save new parameter (2)
- ▶ Scroll RIGHT/DOWN (3)

Once you enter programming mode, press ◀ or ▶ to scroll LEFT or RIGHT to the various menus (RENAME HOPPER, EDIT COFFEE NAME, NON-GRIND PROG, etc.). Press ⊙ (SELECT) to enter a menu. Then press ◀ or ▶ to scroll UP or DOWN through a menu. When the desired menu item appears on the screen, press ⊙ (SELECT) to access. See *Programming Options* for detailed descriptions.

Batch/Grind Time Menu

This menu changes the default grind settings for the the left and right hoppers. Changing the settings for one type does not affect any of the others.

LEFT/RIGHT HOPPER: - is used to select the left or right hopper. Press ◀ or ▶ to toggle between the LEFT HOPPER and RIGHT HOPPER. Selecting Ⓞ advances to the next menu item.

SMLL TIME: - sets (or turns off) the small grind time for the selected coffee. Press ◀ or ▶ (- or +) to decrease or increase the number of seconds. Press Ⓞ to save and move to the next menu item.

MED TIME: - sets (or turns off) the medium grind time for the selected coffee. Press ◀ or ▶ (- or +) to decrease or increase the number of seconds. Press Ⓞ to save and move to the next menu item.

LRG TIME: - sets (or turns off) the large grind time for the selected coffee. Press ◀ or ▶ (- or +) to decrease or increase the number of seconds. Press Ⓞ to save and move to the next menu item.

CHUTE TIME (Run-Off): - sets (or turns off) the amount of time it takes for the motor to shut off after the auger stops turning. Press ◀ or ▶ (- or +) to decrease or increase the number of seconds. Press Ⓞ to save and move to the next menu item.

SAVE CHANGES: - allows review of the coffee name one last time before saving. Press ◀ or ▶ to toggle between YES and No. Press Ⓞ to select. Selecting NO, exits directly to the programming menu.

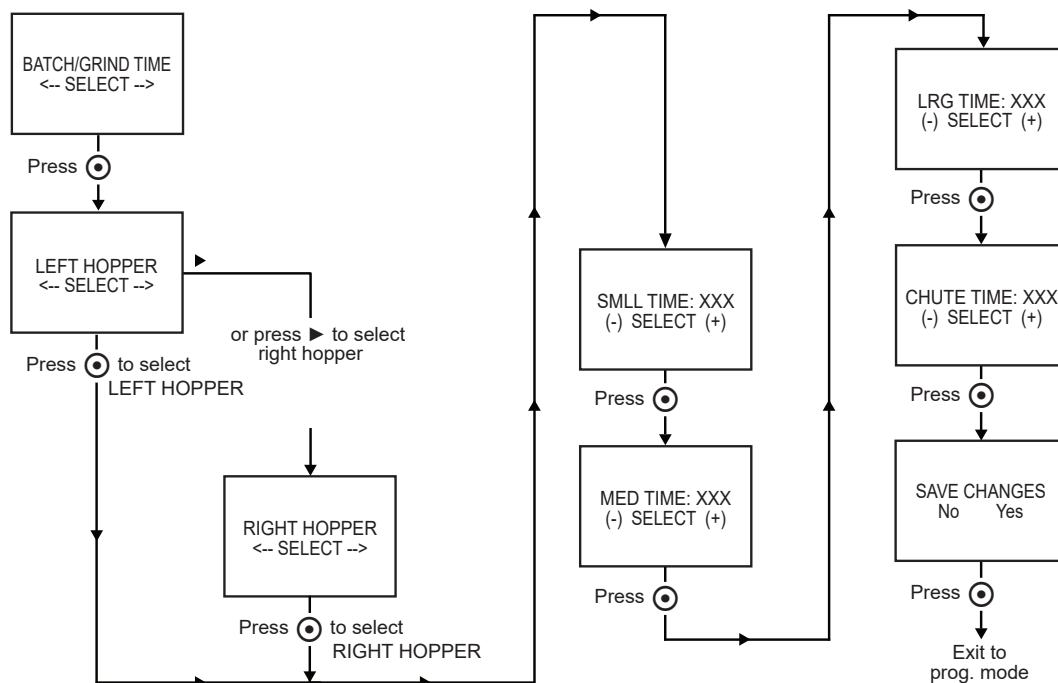



IMPORTANT: Use the following time settings as a general guide. Actual amounts will vary with the grinding burr setting (see *Grinder Adjustment Procedure* in the *TROUBLESHOOTING GUIDE*) and the specific coffee variety used. After changing the timer, weigh the output, then make adjustments if necessary.

Seconds	Ounces (Estimated)	Seconds	Ounces (Estimated)
4	1.3	15	4.5
5	1.5	20	6.2
6	1.8	25	7.6
7	2.0	30	8.8
8	2.5	35	10.0
10	3.0	40	11.8
12	3.7	45	13.5

Rename Hopper Menu

This menu programs/changes the hopper name to a particular type of coffee, if desired. To change to a different grind time, see *Edit Coffee Name Menu*. When you first enter the RENAME HOPPER menu, pressing ◀ or ▶ selects the hopper to be programmed (left or right). Press ● to select the hopper side. You will be prompted to insert the hopper to be programmed.

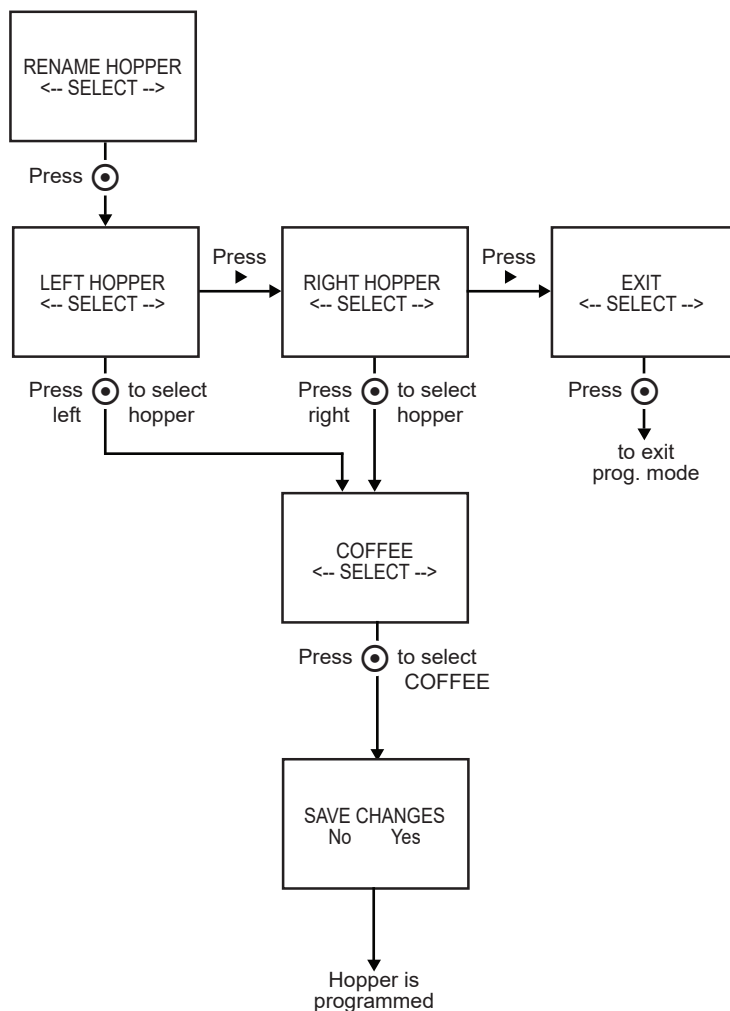

Non-Grind Programming Menu

Master Reset - resets many of the grinders universal control module (UCM) settings to the factory defaults. Parameters that are reset are: Beeper ON/OFF, Grind Odometer, Rename Hopper and Units. Once accessed, "Are You Sure?" will appear on the display. Press ◀ for Yes or ▶ for No.

Service Call - sets the phone number that appears on the display when the UCM detects certain types of malfunctions. Once accessed, press ◀ or ▶ to choose the number to be changed. Then press Ⓞ repeatedly to change the number value. Press ◀ or ▶ to choose the next number to change or choose EX and press Ⓞ.

P-Maintenance - turns on/off, adjusts and resets the P-Maintenance (preventive maintenance) grind monitor (the factory default is OFF). When ON, the UCM measures the amount of coffee ground before the P-Maintenance reminder appears on the display. It is programmable in 100 lb. (45 kg) increments. Once accessed, press ◀ or ▶ to choose the desired setting, then, press Ⓞ to exit.

Banner Name - changes the banner name that appears on the display (the factory default is CURTIS). No banner name appears when all blanks are entered. Once accessed, press ◀ or ▶ to choose the letter to change. Then press Ⓞ repeatedly to change the letter itself. Press ◀ or ▶ to choose the next letter to change or choose EX and press Ⓞ to exit.

Access Code - sets the access code entered to access programming mode (the factory default is 1-2-3-4). Once accessed, press ◀ or ▶ to choose the number to change. Then press Ⓞ repeatedly to change the number value (range is 1 to 4). Press ◀ or ▶ to choose the next number to change or choose exit and press Ⓞ.

Beeper On/Off - turns the beeper that is heard each time a button is pressed on or off (the factory default is ON). Once accessed, press ◀ or ▶ to choose the desired setting. Then, press Ⓞ to exit.

Grind Total - when accessed, displays the total weight ground by the grinder. It cannot be reset. The display returns to the previous screen automatically after a few seconds.

Grind Odometer - When accessed, this feature displays the total weight ground since the odometer was last reset. Press ◀ to exit or Ⓞ reset and exit.

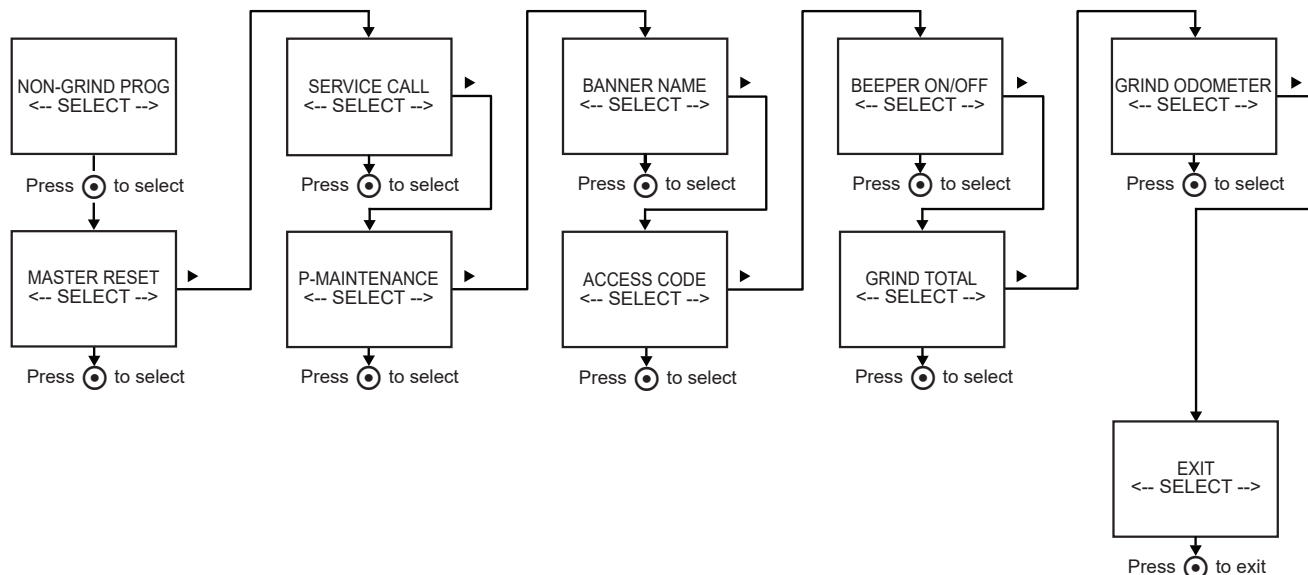

Language Menu - changes the language that appears on the display. Available languages are English (factory default), French, Spanish, German and Dutch. Once accessed, press ◀ or ▶ to choose the desired setting, then press ⊙ to exit.

Units Menu - programs the measurement units that appears on the display (the factory default is US). Once accessed, press ◀ or ▶ to choose the desired setting (US or SI), then press ⊙ to exit.

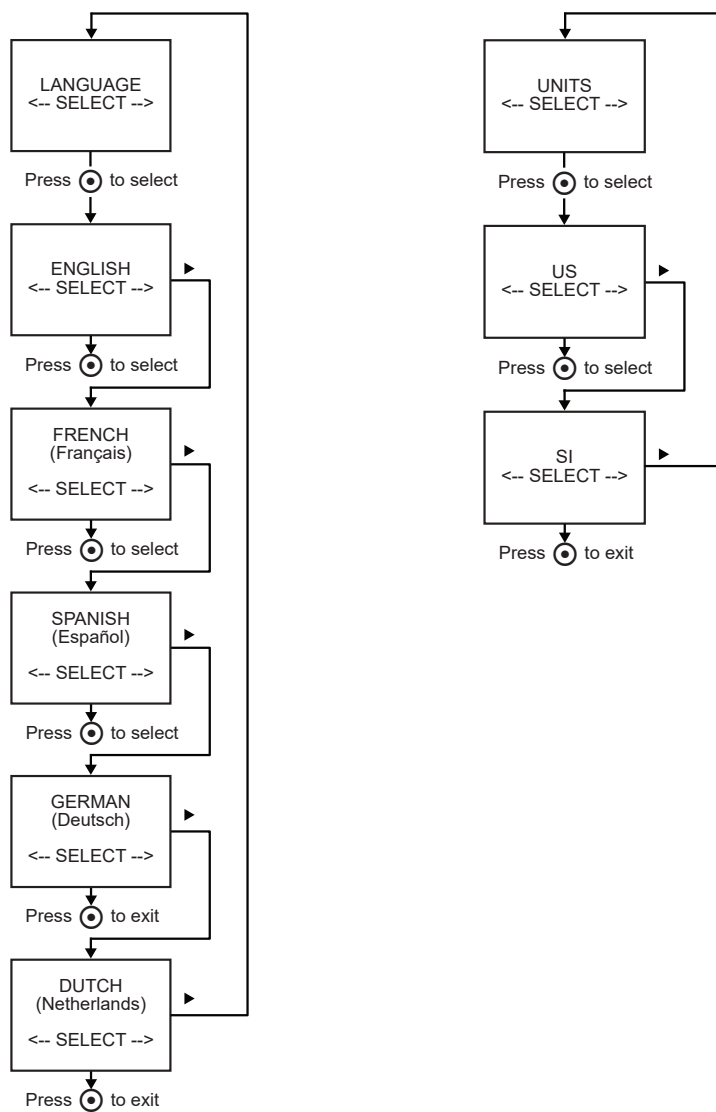

Rough-In Drawing

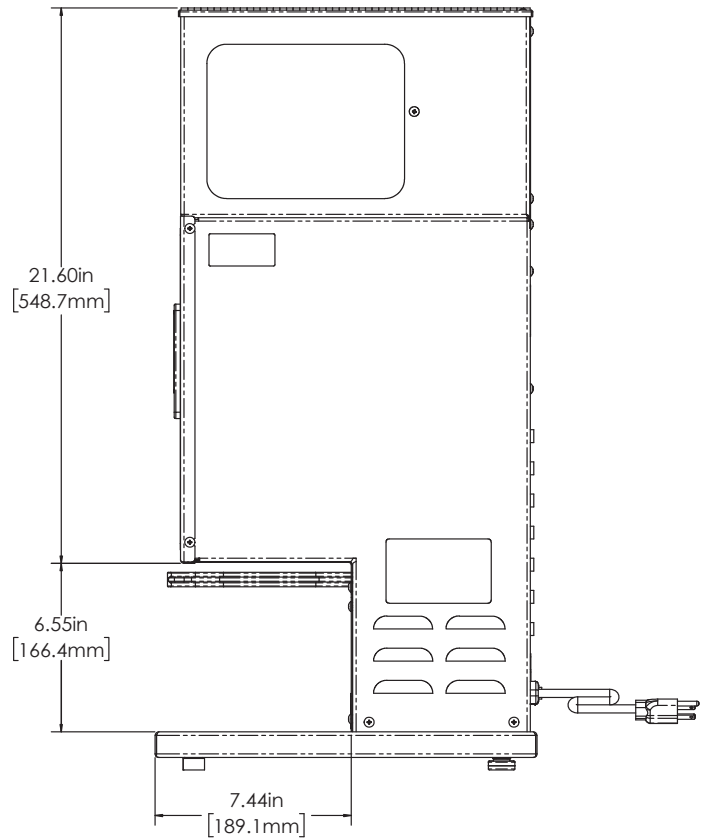
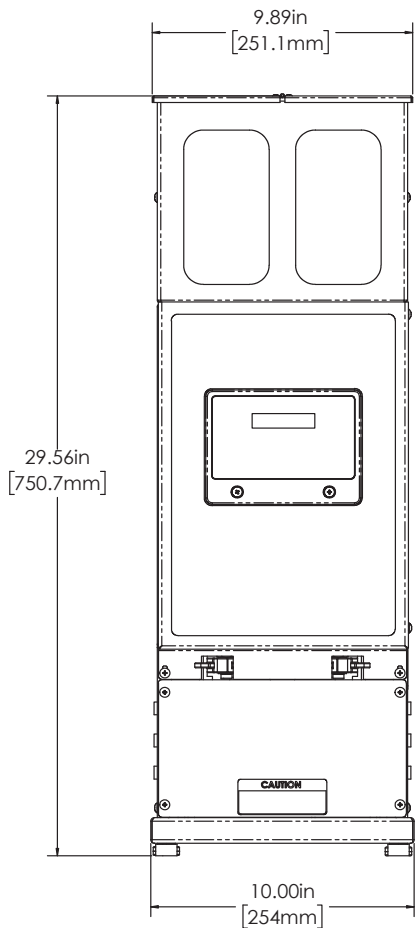
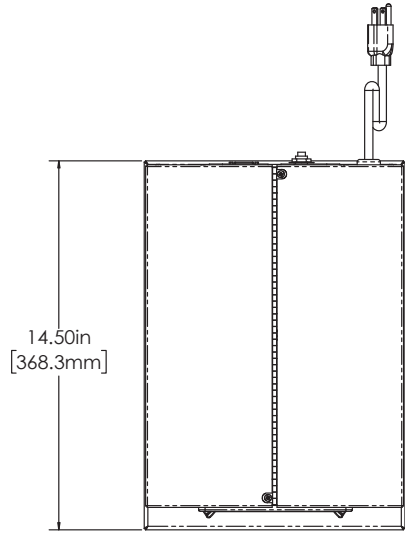

Illustrated Parts List (Main Chasis)

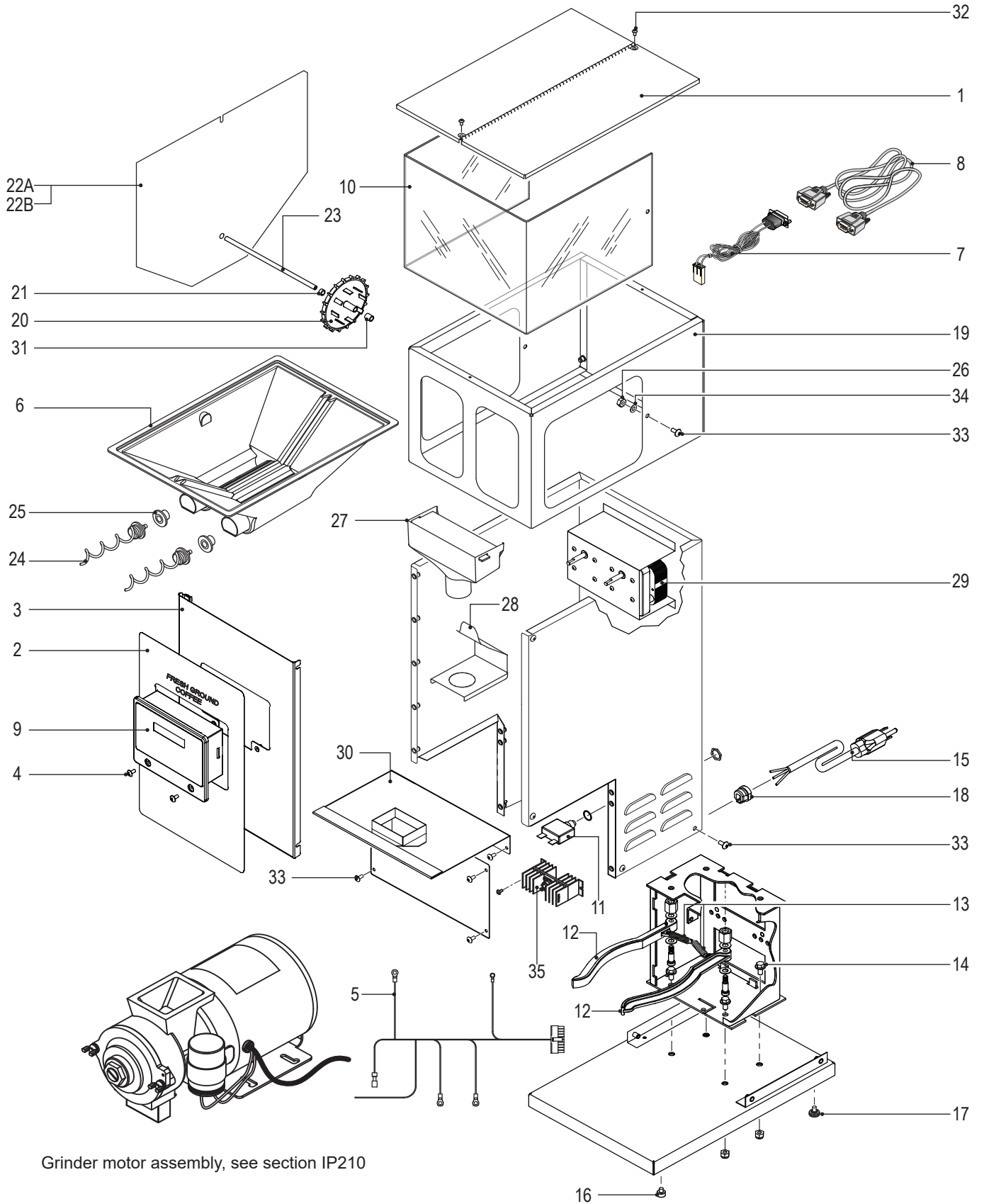

Grinder motor assembly, see section IP210

ILGD Parts List (Main Chassis)

ITEM #	PART #	DESCRIPTION
1	WC-9118	COVER, ASSY DUAL HOPPER
2	WC-390691	LABEL, ILGD-10
3	WC-5882-101K	COVER, FRONT ASSY
4	WC-4442	SCREW, 8-32x3/8 PH HEAD TRUSS BLACK
5	WC-13497	HARNESS ASSY, COMPLETE 120/240V
6	WC-9116	HOPPER ASSY, DUAL GRINDERS
7	WC-37339	KIT, INTERLOCK CABLE & CONNECTOR
8	WC-1467	CABLE ASSY, INTERLOCK
9	WC-689-E	CONTROL MODULE, UCM 120/240V ILGD
10	WC-9131	WINDOW, ACRYLIC DUAL GRINDER
11	WC-1504	BREAKER, CIRCUIT 10A 120/250 VAC
12	WC-9141	BASKET HOLDER
13	WC-9155	SPRING FOR BASKET HOLDER
14	WC-4817	BOLT, 1/4-20UNC x 1/2 HEX HD w/Ø5/8 FLANGE
15	WC-1200	CORD, 14/3 SJTO 6' BLK W/PLUG
16	WC-3503	LEG, 3/8"-16 STUD SCREW BUMPER
17	WC-3518	LEG, GLIDE 3/8"-16 STUD SCREW
18	WC-1408	CORD GRIP, 7/8" O.D.
19	WC-91013	WRAP, W/A DUAL HOPPER ILGD
20	WC-9160	WHEEL, GRINDER AGITATION CCG (OPTIONAL)
21	WC-9144	SPACER, 9/32 AGITATION WHEEL (OPTIONAL)
22A	WC-9132	DIVIDER, DUAL HOPPER SS
22B	WC-9188	DIVIDER, W/HOLE (OPTIONAL)
23	WC-9142	SHAFT, AGITATION WHEEL (OPTIONAL)

ITEM #	PART #	DESCRIPTION
24	WC-9158	AUGER, ASSY
25	WC-9183	BEARING, AUGER
26	WC-4275	NUT, 8-32 LOCK NYLON INSERT SS
27	WC-9130	FUNNEL, ILGD/TL-ILGD,DHGILD, DHG,ILG
28	WC-9134	SHIELD, HOUSING
29*	WC-9151	MOTOR, GEAR 115V DUAL GRINDER
30	WC-9126	GUIDE, SPOUT WELD ASSY
31	WC-9143	SPACER, 5/8" AGITATION WHEEL (OPTIONAL)
32	WC-4439	SCREW, 6-32x¼ PHIL PAN HD SS
33	WC-4426	SCREW, 8-32x3/8 PH HEAD TRUSS
34	WC-4309	WASHER, #10, FLAT SS .20 ID x .44 OD x .06 THICK
35	WC-8556	HEATSINK ASSY W/TRIAC

Illustrated Parts List (Motor)

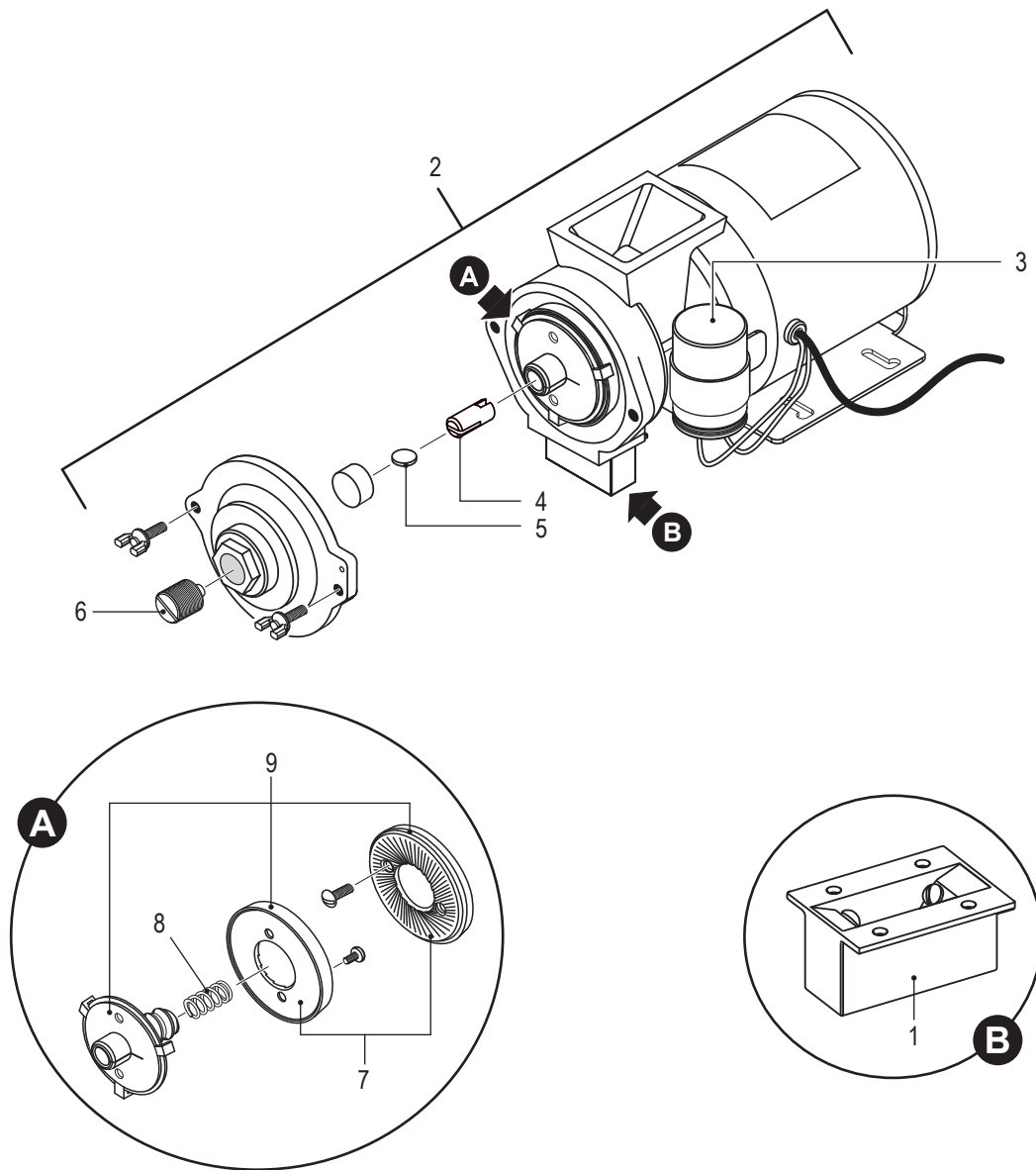

Grinder Motor Assembly - Parts List

ITEM #	PART #	DESCRIPTION
1	WC-37283*	KIT, GRINDER CHUTE DHG/ILGD/SH
2	WC-9135	MOTOR, SLICING GRINDER ASSY 120V SLG/DHG/ILGD/ILGS/SHG
3	WC-91026	CAPACITOR, COFFEE GRINDER ASSY SLG/DHG/ILGD
4	WC-91024	SHEAR, DRIVE COFFEE GRINDER NI+SN PLATING SLG/DHG/ILGD
5	WC-9107-6*	DISC, SHEAR COFFEE GRINDER 6PK
6	WC-91015	SCREW AND THRUST PIN, ADJUSTING ASSY SLG/DHG/ILGD (NEWER UNITS)
7	WC-91050	BURR, COMPLETE SET SLICING (NEWER UNITS)
8	WC-91021	SPRING, TENSION COFFEE GRINDER SLG/DHG/ILGD
9	WC-91051	FEEDWORM, SLICING GSG (NEWER UNITS)

*Recommended parts to stock

Electrical Schematics

120 Volt Models

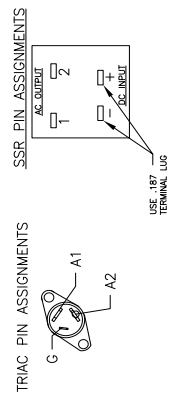
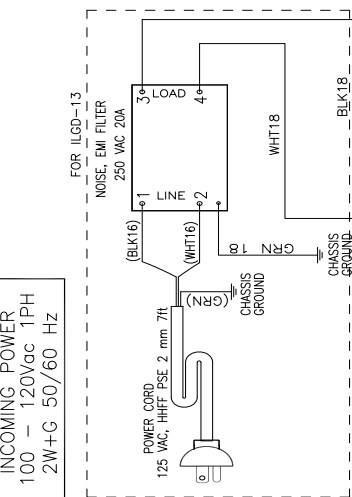
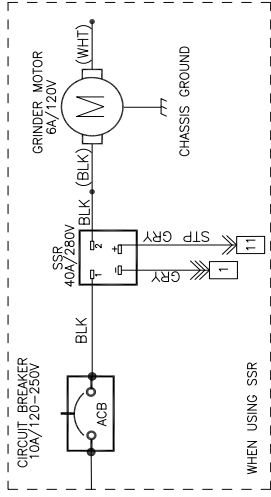
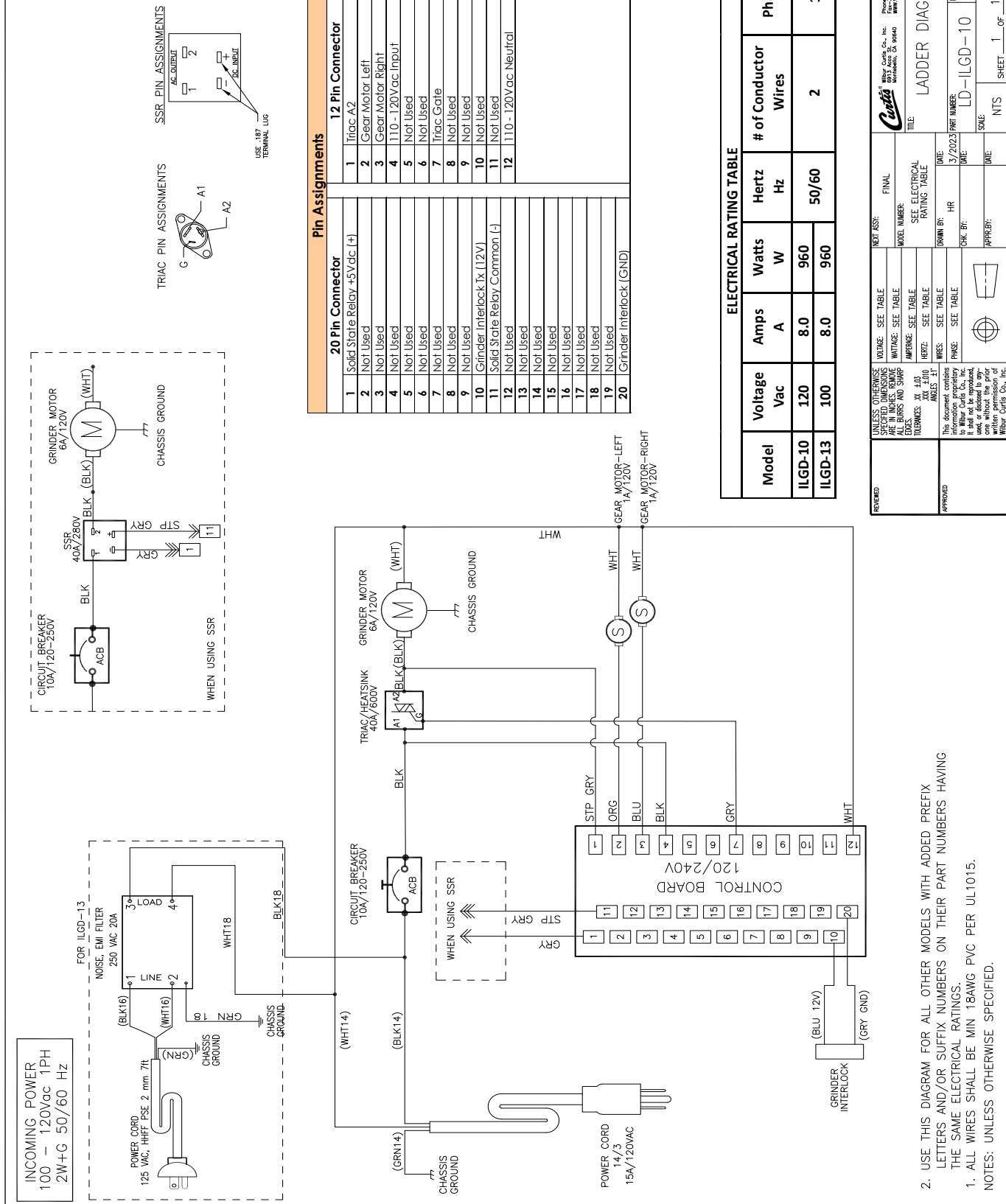

20 Pin Connector		12 Pin Connector	
1	Solid State Relay +5Vdc (+)	1	Triac A2
2	Not Used	2	Gear Motor Left
3	Not Used	3	Gear Motor Right
4	Not Used	4	110 - 120Vac Input
5	Not Used	5	Not Used
6	Not Used	6	Not Used
7	Not Used	7	Triac Gate
8	Not Used	8	Not Used
9	Not Used	9	Not Used
10	Grinder Interlock (X 12V)	10	Not Used
11	Solid State Relay Common (-)	11	Not Used
12	Not Used	12	110 - 120Vac Neutral
13	Not Used		
14	Not Used		
15	Not Used		
16	Not Used		
17	Not Used		
18	Not Used		
19	Not Used		
20	Grinder Interlock (GND)		

Model	ELECTRICAL RATING TABLE		Phase	
	Voltage Vac	Amps A		Watts W
ILGD-10	120	8.0	960	1
ILGD-13	100	8.0	960	

REVISIONS

APPROVED

UNLESS OTHERWISE SPECIFIED:
DIMENSIONS ARE IN INCHES, FRACTIONS AND DECIMALS SHALL BE IN INCHES.
TOLERANCES: XX .±03
XXX .±010
ANGLES .5°

THIS DOCUMENT CONTAINS PROPRIETARY INFORMATION OF WILBUR CORP. CO., INC. IT IS NOT TO BE REPRODUCED, COPIED, OR TRANSMITTED IN ANY FORM OR BY ANY MEANS WITHOUT THE WRITTEN PERMISSION OF WILBUR CORP. CO., INC.

Next Assy: FINAL

Model Number: SEE ELECTRICAL RATING TABLE

Drawn By: HR

Check By:

Appr'd By:

Scale: NTS

Sheet: 1 OF 1

Revision: A

Wilbur Corp. Co., Inc.
10000 Wilbur Blvd., Suite 200
Wilbur, CA 94593
Phone: 925-937-2300
Fax: 925-937-2400
www.wilburcorp.com

Title: LADDER DIAGRAM

Part Number: LD-ILGD-10

Drawing Size: C

- USE THIS DIAGRAM FOR ALL OTHER MODELS WITH ADDED PREFIX LETTERS AND/OR SUFFIX NUMBERS ON THEIR PART NUMBERS HAVING THE SAME ELECTRICAL RATINGS.
 - ALL WIRES SHALL BE MIN 18AWG PVC PER UL1015.
- NOTES: UNLESS OTHERWISE SPECIFIED.

Troubleshooting (General)



WARNING: Electric Shock Hazard - The procedures in this troubleshooting guide should *only* be performed by a qualified service technician. Disconnect power when replacing components. Neither Wilbur Curtis Co., Inc., nor the seller are responsible for the interpretation of this information, or any liability in connection with its use.

Troubleshooting Guidelines

- This troubleshooting guide identifies the probable causes of some common issue that can occur.
- Use this troubleshooting guide along with the appropriate *ELECTRICAL SCHEMATIC*.

Grinder Does Not Grind Coffee - None of the Motors Run*

**Including the auger gear motors.*

- 1 Confirm that the power cord is plugged into an electrical outlet and that the corresponding circuit breaker for the outlet is working.
- 2 Check the circuit breaker on the back of the unit. Push the button to reset. If the button pops back out, check for electrical shorts inside the unit. For example, a shorted motor.
- 3 Confirm that the control module is receiving power. The front panel should illuminate when the grinder is plugged into a working electrical outlet. If it is not receiving power, use the *ELECTRICAL SCHEMATIC* to help you trace backward from the control module to the power cord to find the wire or component that is preventing the control module from getting power.
- 4 Confirm that all the buttons on the touch screen are working. If one or more do not work, refer to the steps under *Only some of the buttons work*.
- 5 If the control module is receiving power, try running one or more of the grind selections. If *none* of the motors are receiving power:
 - Confirm that the Triac is receiving power. If power is going into the Triac, but not out to the rest of the circuit, check for power at the terminal gate.
 - Check the wire connecting the control module to the A2 terminal.
 - If the Triac is not receiving power from the control module, then the control board is defective.
 - If all connections are good and power is reaching the Triac, but voltage is not leaving the A2 terminal, you will need to replace the Triac.

Grinder Only Grinds Coffee One Side

- 1 Disconnect power cable from the electrical outlet and confirm that the funnel feeding beans into the malfunctioning side of the grinder is not clogged or jammed.
- 2 If there are no issues with the funnel, check the gear motor wiring, and confirm that the control module is supplying power to the gear motor. If the gear motor is not receiving power, the control module is bad.
- 3 If the gear motor is receiving power and all connections are fine, then the gear motor is defective.

Coffee Does Not Grind on Either Side, But the Grinder Motor Runs

- 1 Disconnect power cable from the electrical outlet and confirm that the funnels feeding beans into each side of the grinder are not clogged or jammed.
- 2 If there are no issues with the funnels, check for a broken shear disk on the grinder motor assembly. See *Replacing a Broken Shear Disk*.

Grinder Does Not Grind on Either Side - Grinder Motor DOES NOT Run, But Gear Motors are Turning

- 1 Confirm that power is reaching the input terminals of the grinder motor. If there is power at the input terminals of the motor, but it does not run, either the motor capacitor or the motor itself is defective.
- 2 Check the wiring to the grinder motor.
- 3 Confirm that the control module is supplying power to the motor when you start a grind selection. If the motor is not receiving power, then the control module is defective.

Only Some Buttons Work

If the front of the control module lights up, but the unit does not function when trying to run one or more grind selections, or program the grinder, the control module may be defective.

Ground Coffee is Too Course or Too Fine

- 1 Disconnect power cable from the electrical outlet and confirm that the the grinder motor housing cover is and properly seated.
- 2 Try adjusting the grinding burrs. See *Grinder Adjustment Procedure*.

If adjusting the grinding burrs does not work, the grinding burrs may be worn and require replacement.

Grinder Shuts Off Before Brew Basket is Filled

To adjust the volume of coffee ground, adjust the timer. See *PROGRAMMING GUIDE*.

Troubleshooting (Grinder Adjustment)



WARNING: Electric Shock Hazard - Turn off power while removing and replacing the front cover. Keep hands, other body parts and tools clear of electrical wiring during the following procedures.

The grinder can be adjusted to make the ground coffee more fine or more coarse. Adjusting the grinder may affect the output volume. To compensate, adjust the timer (see **Setting the Timer**).

- 1 Remove the coffee beans from the hopper.
- 2 Run the grinder to clear the grinding burrs of remaining coffee.
- 3 Disconnect the power cord.
- 4 Remove the front cover.
- 5 Locate the adjusting screw and lock nut on the front of the grinder motor. Loosen the lock nut (1).
- 6 Run the motor during adjustment, turning the adjustment screw (2) clockwise will result in a finer grind. If you hear the grinding burrs starting to touch, immediately, back off 1/8th turn. Turning the screw counter-clockwise will produce a coarser grind.
- 7 To lock in the setting, hold the adjustment screw in place with a screwdriver and tighten the lock nut.
- 8 Grind some coffee beans to determine if the desired fineness/coarseness has been achieved.
- 9 Disconnect the power cord and replace the front cover.

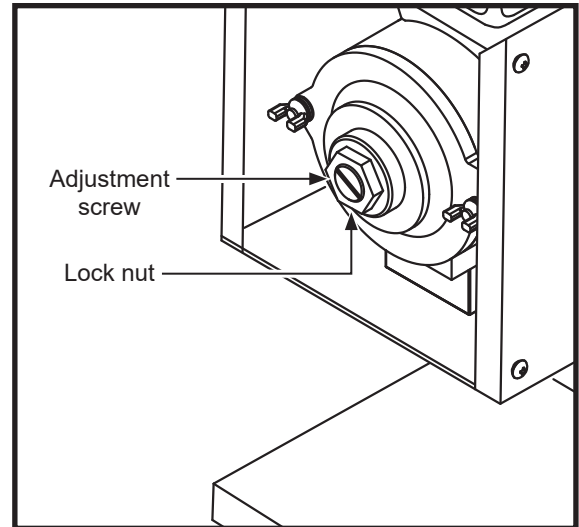

Replacing a Broken Shear Disk

- 1 Remove the coffee beans from the hopper.
- 2 Disconnect the power cord.
- 3 Remove the front cover.
- 4 On the grind motor assembly, take out the two thumb screws and remove the housing cover.
- 5 Pull out the grinding burr/feed worm assembly. The inner half of the grinding burrs will remain within the housing.
- 6 Separate the shear cap and shear drive. The broken shear disk should fall out from the slot on the drive.
- 7 Inspect the housing and clean out any coffee or debris. Look for something that could have gotten caught inside the housing that would have caused the shear disk to break.
- 8 Re-insert the feed worm and grinding burr on the motor shaft.
- 9 Push the shear drive through the burr/feed worm assembly and align the large slot with the tongue on the motor shaft.
- 10 Rotate the burr/feed worm assembly to align the slot with the narrow slot on the shear drive.
- 11 Slip a new shear disk into the slot. Cover it with the shear cap.
- 12 Replace the grind cap and thumb screws.
- 13 Replace the front cover.

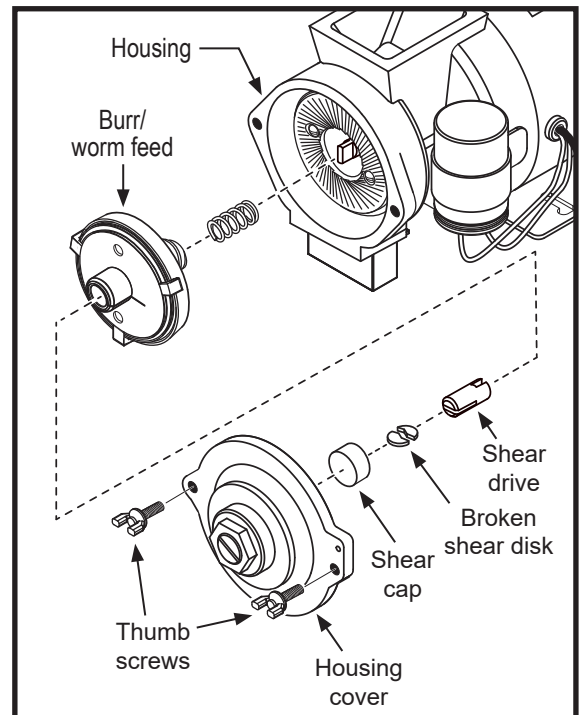

Product Warranty

Wilbur Curtis Co., Inc. certifies that its products are free from defects in material and workmanship under normal use. The following limited warranties and conditions apply:

- 3 years, parts and labor, from original date of purchase on digital control boards
- 2 years, parts, from original date of purchase on all other electrical components, fittings and tubing
- 1 year, labor, from original date of purchase on all other electrical components, fittings and tubing

Additionally, Wilbur Curtis Co., Inc. warrants its grinding burrs for four (4) years from the date of purchase. Stainless steel components are warranted for two (2) years from the date of purchase against leaking or pitting. Replacement parts are warranted for ninety (90) days from the date of purchase or for the remainder of the limited warranty period of the equipment in which the component is installed.

All in-warranty service calls must have prior authorization. For authorization, call the Technical Support Department at 800-995-0417. Additional conditions may apply. Go to www.wilburcurtis.com to view the full product warranty information.

CONDITIONS & EXCEPTIONS

The warranty covers original equipment at time of purchase only. Wilbur Curtis Co., Inc., assumes no responsibility for substitute replacement parts installed on Curtis equipment that have not been purchased from Wilbur Curtis Co., Inc. Wilbur Curtis Co., Inc. will not accept any responsibility if the following conditions are not met. The warranty does not cover:

- **Adjustments and cleaning:** *The resetting of safety thermostats and circuit breakers, programming and temperature adjustments are the responsibility of the equipment owner. The owner is responsible for proper cleaning and regular maintenance of this equipment.*
- **Replacement of items subject to normal use and wear:** *This shall include, but is not limited to, spray heads, faucets, light bulbs, shear disks, "O" rings, gaskets, silicone tubing, silicone elbows, canister assemblies, whipper chambers and plates, mixing bowls, agitation assemblies and whipper propellers.*

The warranty is void under the following circumstances:

- **Improper operation of equipment:** *The equipment must be used for its designed and intended purpose and function.*
- **Improper installation of equipment:** *This equipment must be installed by a professional technician and must comply with all local electrical, mechanical and plumbing codes.*
- **Improper voltage:** *Equipment must be installed at the voltage stated on the serial plate supplied with this equipment.*
- **Improper water supply:** *This includes, but is not limited to, excessive or low water pressure and inadequate or fluctuating water flow rate.*
- **Damaged in transit:** *Equipment damaged in transit is the responsibility of the freight company and a claim should be made with the carrier.*
- **Abuse or neglect (including failure to periodically clean or remove lime accumulations):** *The manufacturer is not responsible for variation in equipment operation due to excessive lime or local water conditions. The equipment must be maintained according to the manufacturer's recommendations.*
- **Unauthorized repair or modification:** *This equipment must be serviced only by qualified service technicians, using factory specified parts to factory specifications.*
- **Modified/Missing Serial Tag:** *The serial number label (tag) must not be defaced or removed.*

Repairs and/or Replacements are subject to Curtis' decision that the workmanship or parts were faulty and the defects showed up under normal use. All labor shall be performed during regular working hours. Overtime charges are the responsibility of the owner. Charges incurred by delays, waiting time, or operating restrictions that hinder the service technician's ability to perform service is the responsibility of the owner of the equipment. This includes institutional and correctional facilities. Wilbur Curtis Co., Inc. will allow up to 100 miles, round trip, per in-warranty service call.

Return Merchandise Authorization (RMA): All claims under this warranty must be submitted to the Wilbur Curtis Technical Support Department prior to performing any repair work or return of this equipment to the factory. **All returned equipment must be properly re-packaged in the original carton and received by Curtis within 45 days following the issuance of a RMA.** No units will be accepted if they are damaged in transit due to improper packaging. **NO UNITS OR PARTS WILL BE ACCEPTED WITHOUT A RETURN MERCHANDISE AUTHORIZATION (RMA). THE RMA NUMBER MUST BE MARKED ON THE CARTON OR SHIPPING LABEL. All warranty claims must be submitted within 60 days of service. Invoices will not be processed or accepted without a RMA number. Any defective parts must be returned in order for warranty invoices to be processed and approved.** All in-warranty service calls must be performed by an authorized service agent. Call the Wilbur Curtis Technical Support Department to find an agent near you.