

**Architectural/Engineering Specification:**  
Connected Sensor Flush Valve

**PRODUCT FEATURES:**

plumbSmart Portal

- Know water consumption
- Track uses per fixture
- Receive real-time alerts
- Manage maintenance tasks
- Receive insights on your data

Flush Valve

- Infrared Sensor
- User in-view L.E.D
- Low battery indicator light
- Optional 24 hour auto-flush setting
- 3 second delay flush
- Override Button
- 6 VDC Motor Actuator
- 4 “C” size batteries (Included)
- Included tools Wrench for installation Allen key for battery compartment



**Product Compliance:**

*\*Although products with certain combinations of options and features will meet or comply with these standards and/or certifications, not every combination of options and features will result in such compliance. If you have any questions about your particular product, please contact our Customer Care Dept. at 1-855-ONE-ZURN (United States) or 1-877-892-5216 (Canada) for confirmation.*

**TECHNICAL SPECIFICATION:**

Connected Endpoint	
•	Communicates wirelessly to Zurn Gateway
•	Fully integrated into the EZ-Flush housing
Zurn Gateway	
•	Communicates via Ethernet or LTE
•	Works with all Zurn connected devices
•	Connects all endpoints up to 1,000 ft radius
•	After purchase request your gateway at: <a href="http://zurn.com/plumbsmart-gateway">zurn.com/plumbsmart-gateway</a> or Call 1-844-987-6737



**GATEWAY OPTIONS:**  
(Required & Sold Separately)

Connected Endpoint	
	-LTE ZGW-LORA-W1-LTE
Note: plumbSMART™ is free-to-connect to a basic plan with an option to upgrade to a premium plan.	
Note: LTE charges will apply to basic plan	

Architectural/Engineering Approval

*Design and dimensional data (inches and [mm]) are subject to manufacturing tolerances and change without notice.*

⚠ WARNING: Cancer and Reproductive Harm – [www.P65warnings.ca.gov](http://www.P65warnings.ca.gov)  
 ⚠ ADVERTENCIA: Cáncer y daño reproductivo – [www.P65warnings.ca.gov](http://www.P65warnings.ca.gov)  
 ⚠ AVERTISSEMENT: Cancer et effets néfastes sur la reproduction – [www.P65warnings.ca.gov](http://www.P65warnings.ca.gov)

## How it works:

Integrated sensors continuously monitor flush valve activations and water usage. This data is transmitted to the Zurn gateway via LoRa communication. The Zurn gateway passes the data into the Zurn cloud where the data is enriched and presented in the plumbSMART web portal and mobile app. Facilities managers and/or maintenance personnel can view all data and trends in the plumbSMART™ portal and may opt to receive real-time alerts via email, text message and/or push notifications if any of these readings exceed customizable parameters for high hourly or daily usage levels. All notifications and alert parameters are adjustable via the plumbSMART™ portal. A maintenance planning tool and data insights hub are available in plumbSMART. For more information, visit <https://www.zurn.com/innovation-efficiency/plumbSMART>.

To access the plumbSMART™ portal, a Zurn Gateway must be installed within 1,000 feet of the connected product, and connected products must be registered in the Zurn plumbSMART™ portal. A single Zurn Gateway can be used to connect hundreds of Zurn connected plumbing products.

## Connecting to the plumbSMART™ Portal:

1. Visit [www.zurn.com/plumbSMART-connect](http://www.zurn.com/plumbSMART-connect) to save time and money on your installation. You can also call us at 844-987-6737
2. Provide the serial number and contact name, email address, and basic information about the installation site.
3. We will activate your plumbSMART™ account, set up your enterprise, and give you guidance on how to register each connected product as you install it.
4. We will send a confirmation email with a link, or you can go to [plumbsmart.zurn.com](http://plumbsmart.zurn.com) to log into your plumbSMART™ account for the first time.
5. Add other users and installers to your plumbSMART™ account.
6. Make sure you and/or your installers have the plumbSMART™ mobile app, which you can download from the iPhone App Store or Google Play.
7. Using the mobile app, scan or enter the serial number to register and locate each connected plumbing product as you install it.
8. Watch the how-to videos in the plumbSMART™ portal's support section if you get stuck, or call us at 844-987-6737 for support.

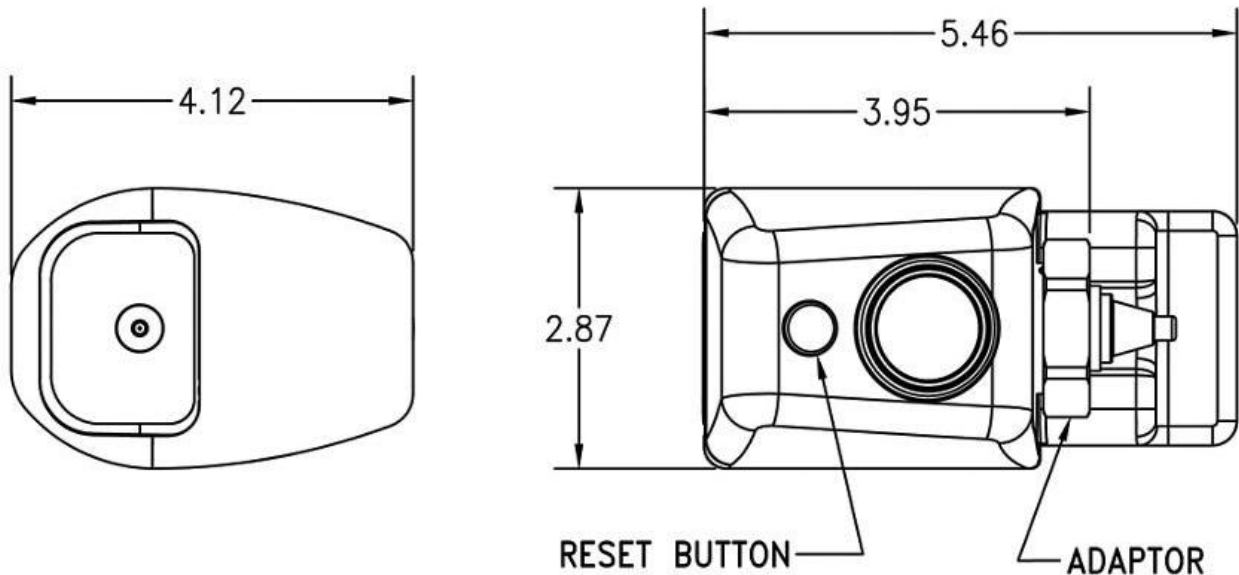

NOTE: All dimensions are for reference only. Do not use for pre-plumbing.