

ITEM	DESCRIPTION	CODE	QTY.	R.S./100
1	SLIDING BAR GUIDE KIT	M571864	1	2
2	LIMIT KNOB	M530779	1	4
3	SLIDING BAR	M571865	1	2
4	LOWER BLADE GUARD KIT	M571866	1	2
5	UPPER SAW GUIDE (S.S.)	M570835	1	2
6	UPPER KNOB	M571295	1	2
7	MAGNETIC SENSOR (UPPER)	M575022	1	2
8	UPPER MAGNET	M575021	1	2
9	KNOB FOR GUARD OF SAW	M571606	1	2
10	DANGER DECAL	M501255	1	2
11	WARNING DECAL	M501254	1	2
12	DANGER DECAL (UPPER BAR)	M501256	1	2
13	DANGER DECAL (GUARD)	M501257	1	2
14	DOOR KNOB KIT	M571867	2	2
15	SCREWS & WASHERS F/SLIDING BAR GUIDE	M572308	1	2
16	SCREWS & WASHERS F/SLIDING BAR	M572309	1	2

R.S.= REQUIREMENT STOCK

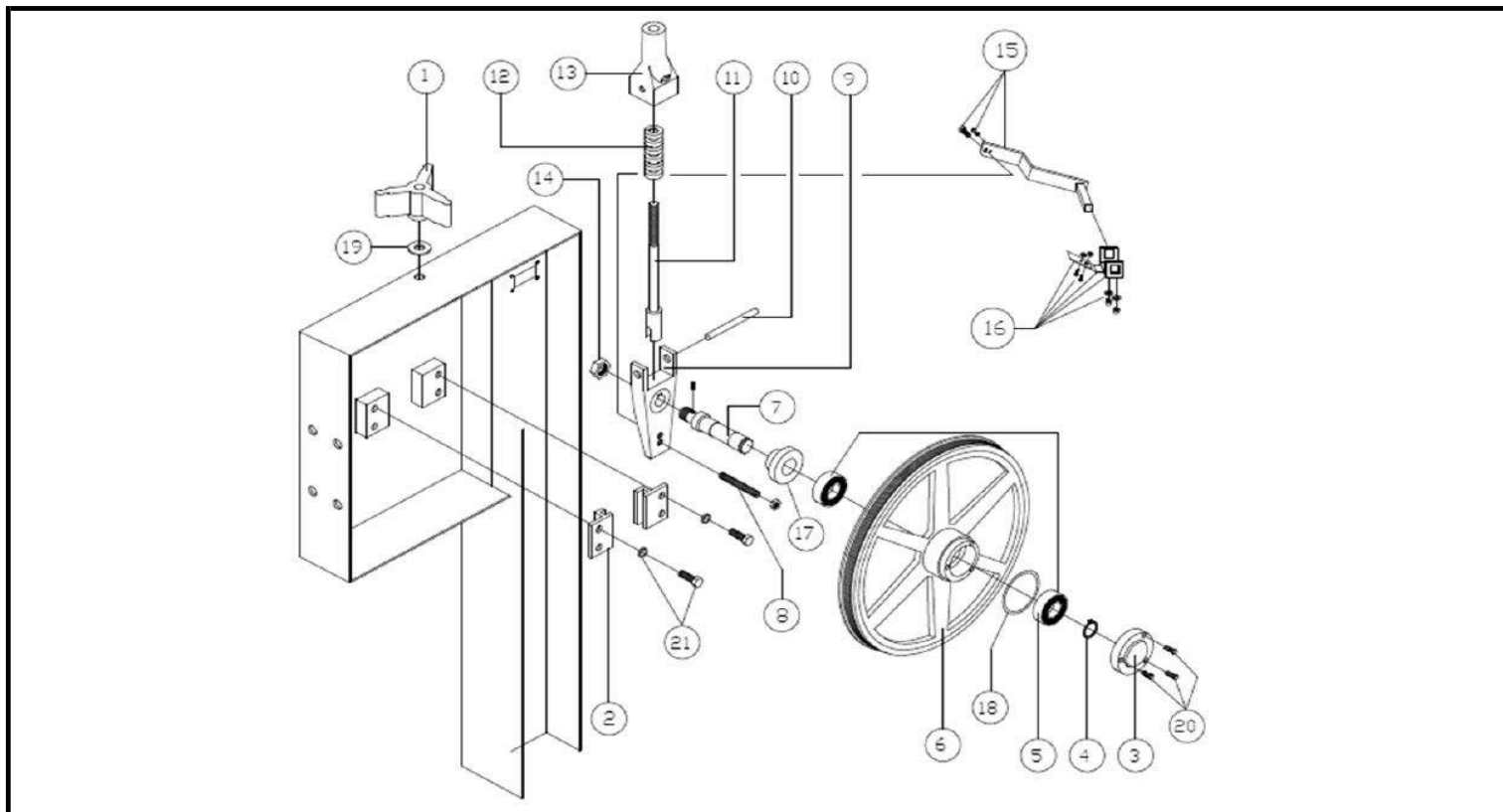

ITEM	DESCRIPTION	CODE	QTY.	R.S./100
1	TENSION HANDLE KIT	M571869	1	2
2	TENSION GUIDES KIT	M571870	1	4
3	BEARING CAP KIT	M571824	2	4
4	RETAINER RING 5100-98	M500282	1	2
5	BEARING 6205	M500185	2	4
6	UPPER WHEEL ø14"	M571110	1	2
7	UPPER SHAFT (S.S.)	M571872	1	2
8	ADJUSTING SCREW KIT FOR UPPER HANGER	M571873	1	2
9	UPPER WHEEL HANGER	M571536	1	2
10	TENSION GAUGE PIN	M570656	1	2
11	ROD & INDICATOR 1/2"	M571535	1	2
12	TENSION GAUGE SPRING	M500290	1	8
13	TENSION GAUGE HOUSING	M571534	1	2
14	HEX. NUT 3/4" N.F. (S.S.)	M570833	1	2
15	UPPER WHEEL SCRAPER ARM KIT	M572679	1	2
16	UPPER WHEEL SCRAPER (CLEANER) KIT	M572680	1	4
17	RUBBER GASKET FOR UPPER WHEEL	M501029	1	2
18	O-RING GASKET #145	M501027	1	2
19	FLAT WASHER 1/2" S.S.	NO REF.	1	4
20	BOLTS 3/16" S.S. KIT	M572793	1	2
21	BOLTS & WASHERS KIT FOR TENSOR GUIDES (S.S.)	M572313	1	2
	TENSOR KIT, INCLUDES ITEMS 8 THROUGH 13.	M571551	1	2
	UPPER WHEEL 14" KIT, INCLUDES ITEMS 3,7,14,17 & 18	M571552	1	2

R.S.= REQUIREMENT STOCK

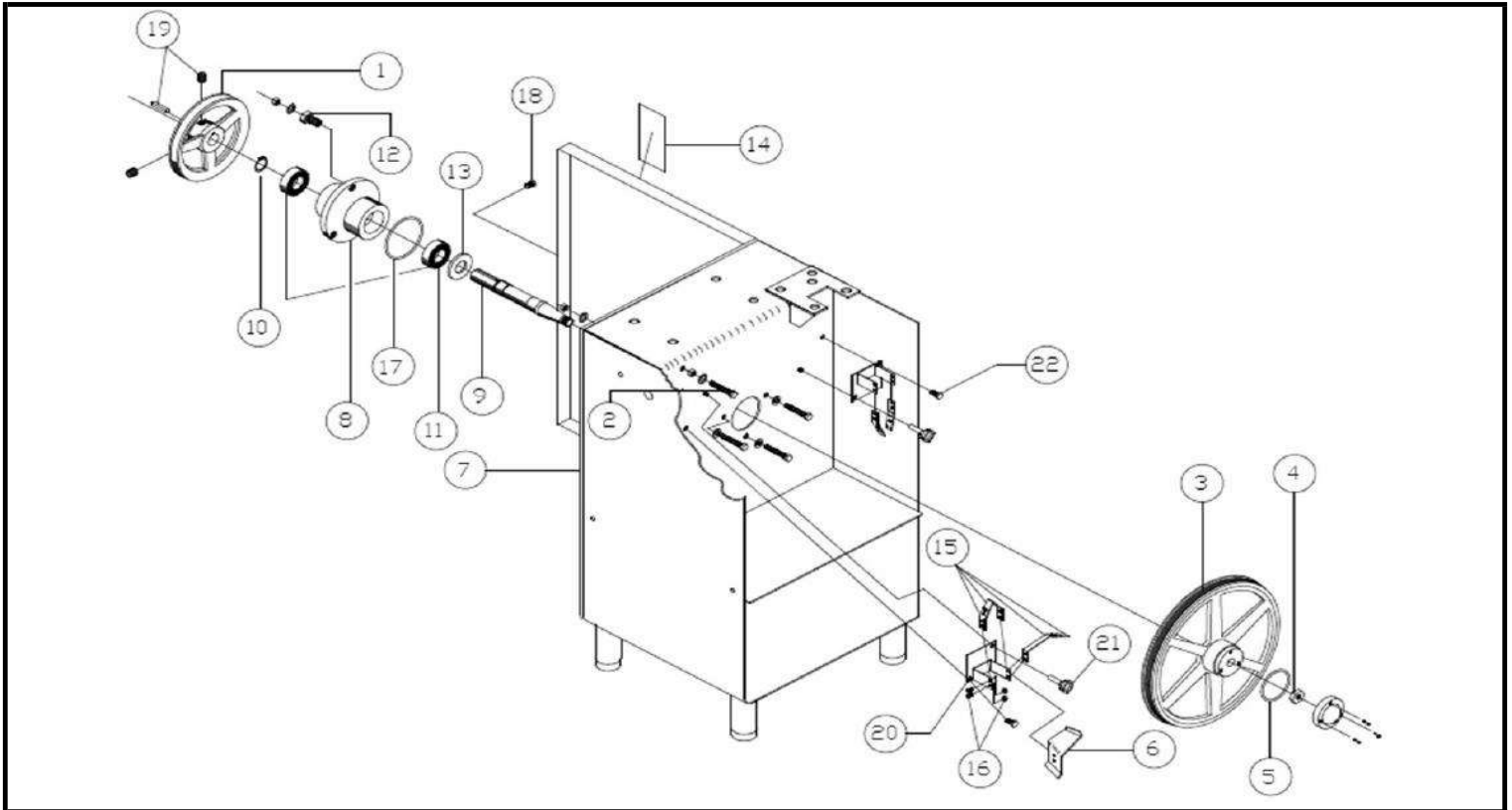

ITEM	DESCRIPTION	CODE	QTY.	R.S./100
1	PULLEY ϕ 8" KIT 60Hz	M571875	1	2
2	SUPPORT BOLT (CARBIDE END) KIT (S.S.)	M571877	1	2
3	LOWER WHEEL ϕ 14"	M571109	1	2
4	HEX. NUT 3/4" N.F. (S.S.)	M570833	1	2
5	O-RING GASKET #145	M501027	1	2
6	SIDING S.S.	M572081	1	2
7	DOOR GASKET	M570718	1	2
8	LOWER MAIN BEARING HOUSING	M571533	1	2
9	LOWER SHAFT (S.S.)	M571878	1	2
10	RETAINER RING 5100-118	M500283	1	2
11	BEARING 6206	M500186	2	4
12	ADJUSTING BOLT FOR BEARING HOUSING	M571879	3	2
13	RETAINER 12631	M501347	1	2
14	WARNING DECAL (MOTOR)	M501253	1	2
15	WHEEL SCRAPER (LOWER) KIT	M572681	1	2
16	BOLTS AND NUT S.S. FOR WHEEL SCRAPER KIT	M572682	1	2
17	O-RING GASKET #2-341	M501037	1	2
18	SCREW HEX. HEAD 1/4" x 1 1/2" S.S.	NO REF.	1	2
19	KEY & SOCKET SET SCREW S.S. KIT	M572314	1	2
20	WHEEL SCRAPER BASE	M572345	2	2
21	KNOB FOR SCRAPER WITH NUT	M572830	2	2
22	SCREW FOR SCRAPER BASE	M571215	2	2
	LOWER MAIN BEARING HOUSING ASSY.	M571655	1	2

R.S.= REQUIREMENT STOCK

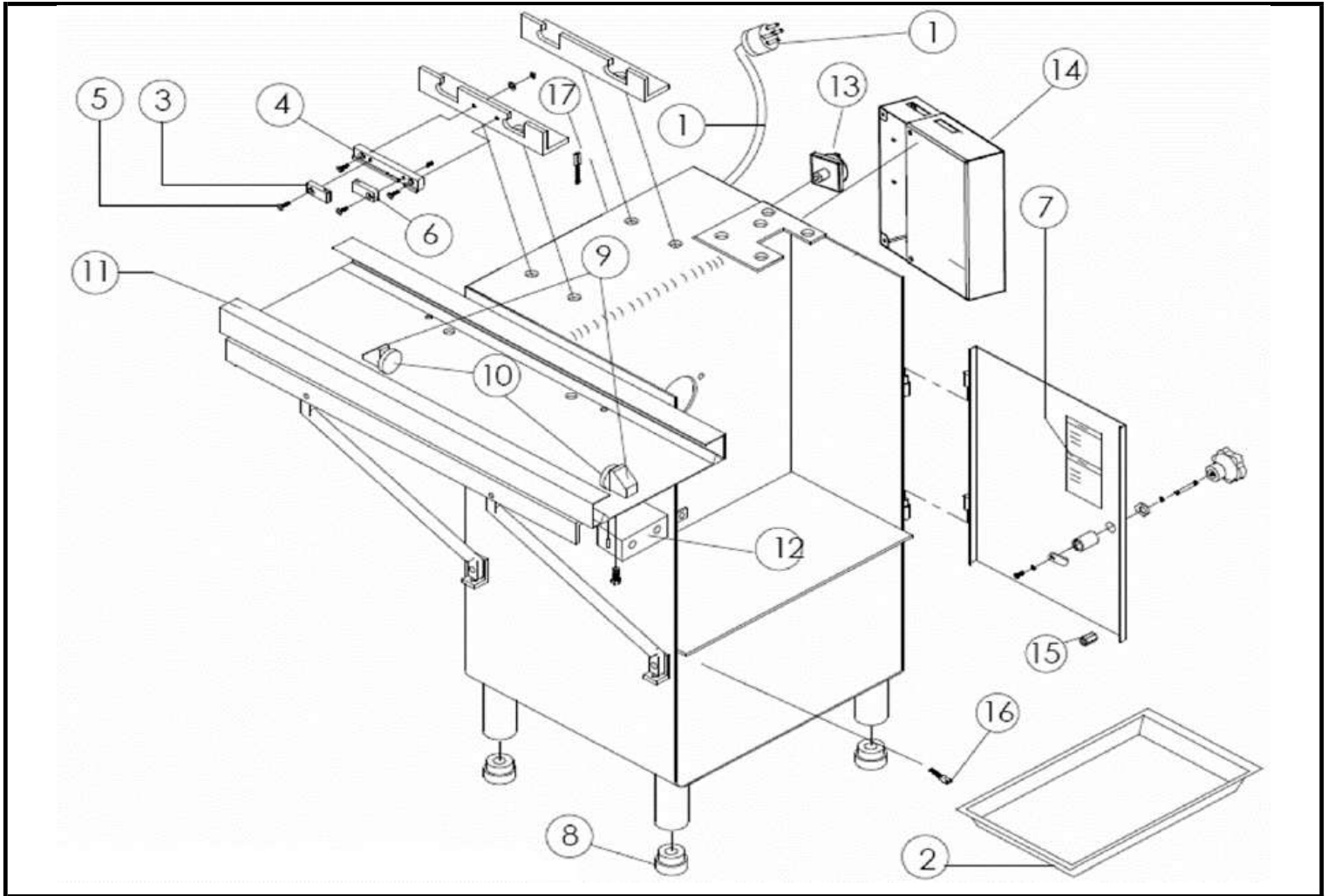

ITEM	DESCRIPTION	CODE	QTY.	R.S./100
1	UL POWER CORD KIT	M500154	1	2
2	SCRAP TRAY (295AI)	M572222	1	2
3	LOWER SAW GUIDE (S.S.)	M570844	1	1
4	GUIDES BASE KIT FOR TENSOR	M571882	1	2
5	BOLT ROUND HEAD 1/4" x 1/2" S.S.	NO REF.	2	2
6	NYLON GUIDE	M570140	1	100
7	DANGER DECAL	M501255	1	2
8	RUBBER PLUG-PAD (MEATSAW)	M500837	4	4
9	STOP CARRIAGE BLOCK KIT	M572683	2	2
10	STOP CARRIAGE BUMPER	M571290	2	4
11	CARRIAGE GUIDE TYPE "V" ASSY.	M573117	1	2
12	PUSH BUTTON BOX KIT	M502135	1	2
13	COMPLETE SINGLE PHASE GENERAL INTERRUPTER	M575025	1	2
14	SINGLE PHASE PC BOARD BOX 110V, 50/60Hz	M503355	1	2
15	LOWER MAGNET	M575020	1	2
16	MAGNETIC SENSOR (LOWER & TABLE)	M575023	1	2
17	MAGNETIC SENSOR (LOWER & TABLE)	M575023	1	2

R.S.= REQUIREMENT STOCK

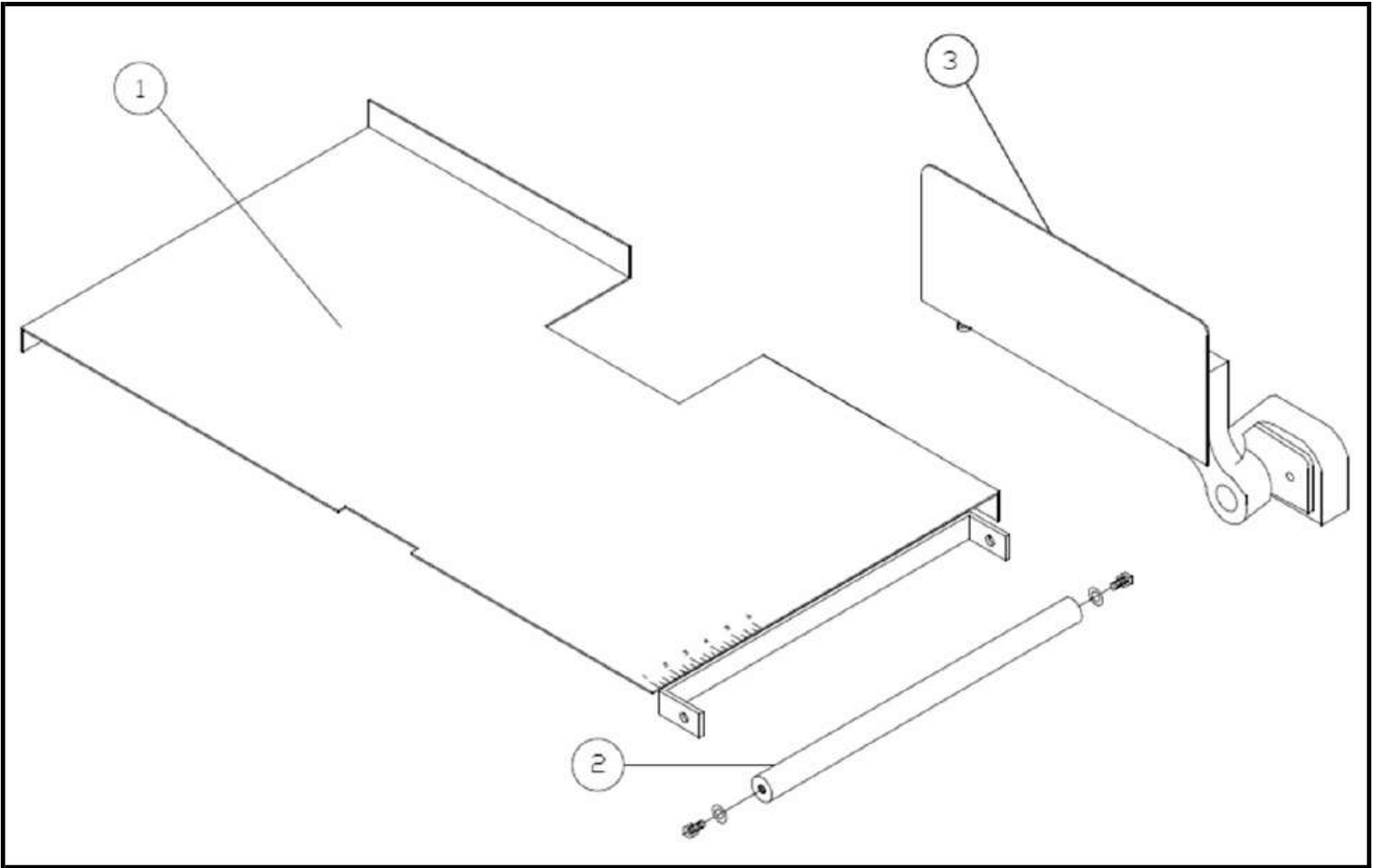

ITEM	DESCRIPTION	CODE	QTY.	R.S./100
1	TABLE ASSY.	M571077	1	1
2	BAR KIT (295, 305)	M573299	1	2
3	GAUGE PLATE ASSY.	M572226	1	2

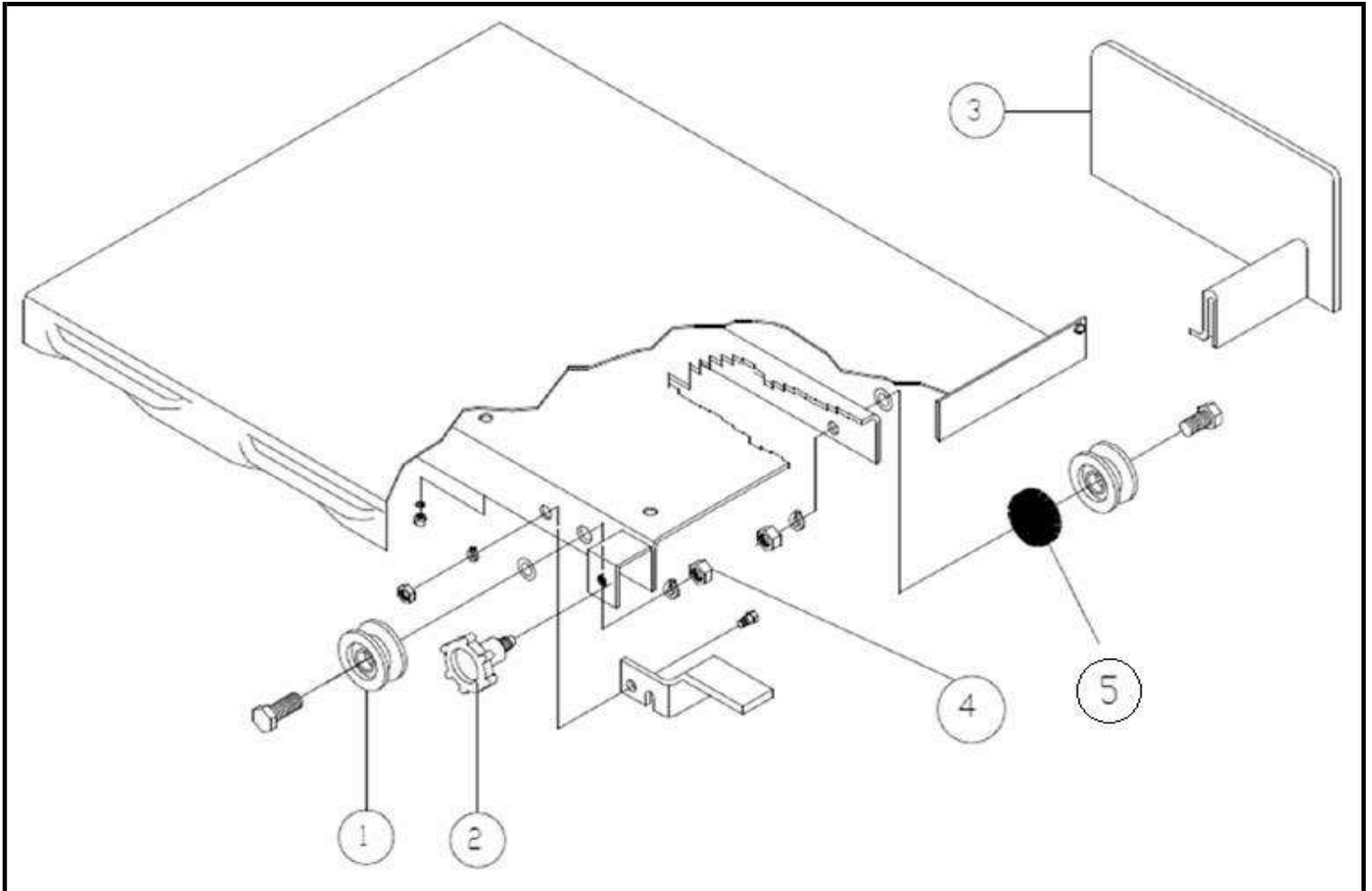

ITEM	DESCRIPTION	CODE	QTY.	R.S./100
1	WHEEL FOR CARRIAGE TYPE "V" (S.S.)	M574465	4	10
2	KNOB FOR CARRIER	M571093	1	2
3	LAST CUT PUSHER	M571618	1	2
4	BOLTS & NUTS KIT FOR CARRIAGE TYPE "V"	M573210	1	2
5	BEARING SS6000 2RS	M503380	1	10
	SLIDING CARRIAGE TYPE "V" KIT	M573161	1	1

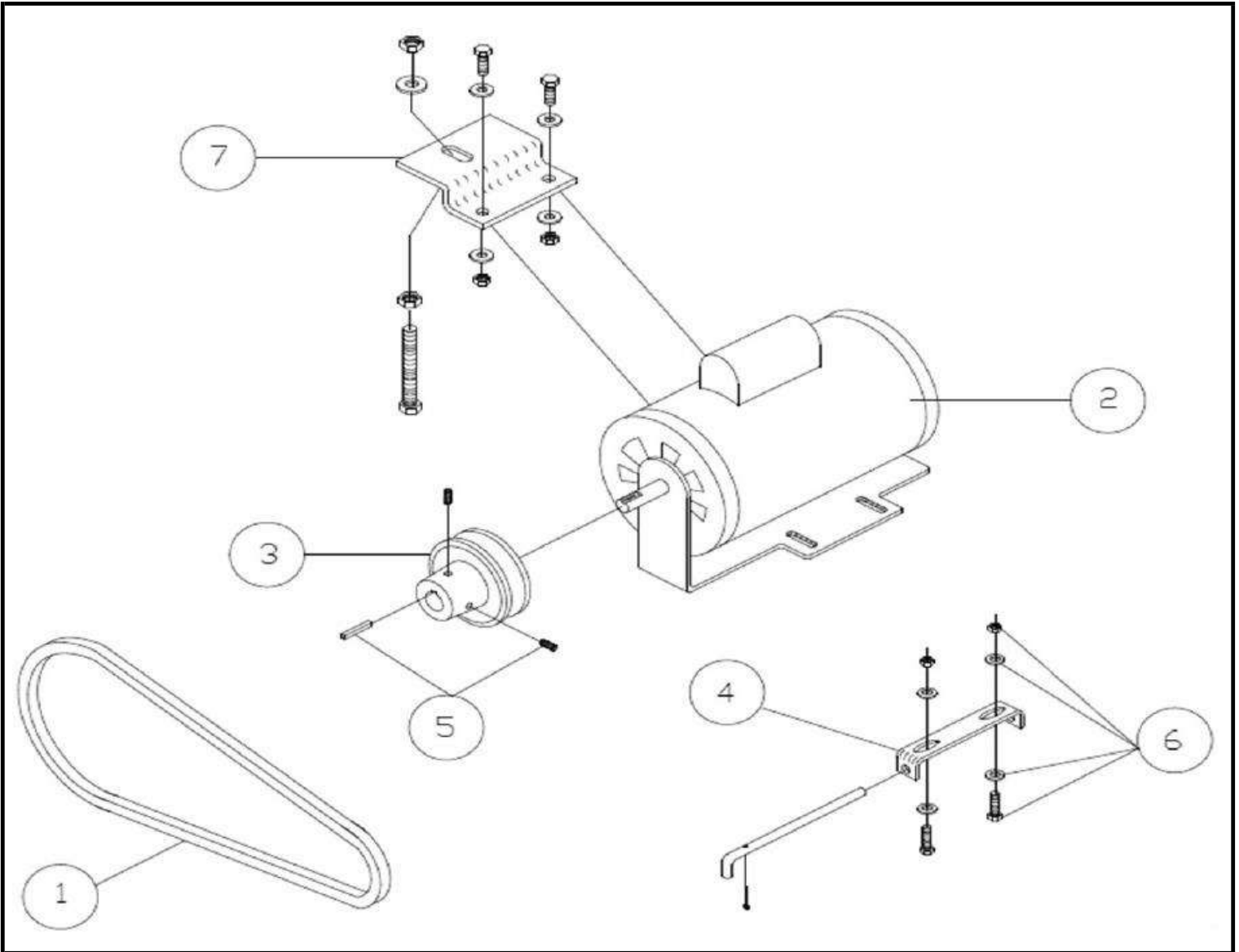

ITEM	DESCRIPTION	CODE	QTY.	R.S./100
1	V-BELT # B-47	M501087	1	2
2	1.5HP MOTOR MONOPHASE 110/220V 60Hz	M500803	1	2
3	PULLEY ϕ 4" KIT (SHAFT ϕ 5/8")	M571838	1	2
4	BRACKET - MOTOR KIT (S.S.)	M571886	1	2
5	KEY & SOCKET SET SCREW S.S. KIT (MOTOR)	M572324	1	2
6	BOLTS, NUTS & WASHERS 5/16" KIT (S.S.)	M572327	1	2
7	MOTOR BASE KIT	M572678	1	2
	1.5HP MOTOR KIT ASSY. (295AI)	M571891	1	2