

OWNER'S MANUAL MEAT SAW

PRO-CUT[®]

OPERATION INSTRUCTIONS

MODELS
KS-116



READ THIS MANUAL BEFORE USING THE EQUIPMENT FOR THE FIRST TIME.

507251-A

INSTRUCTIONS FOR OPERATION, SERVICE AND MAINTENANCE OF THIS EQUIPMENT

CONTENTS:	PAGE
I. INTRODUCTION	1
II. UNPACKING	2
III. INSTALLATION	2
IV. OPERATION	4
V. KEY ELEMENTS IN CUTTING QUALITY PRODUCT	6
VI. CLEANING	6
VII. MAINTENANCE	8
VIII. EQUIPMENT SPECIFICATIONS	9
IX. ELECTRICAL DIAGRAM	9
X. ELECTROMAGNETIC BRAKE (SOME MODELS ONLY)	10

I.- INTRODUCTION:

Congratulations!, you have acquired a Meat Saw, which is made of high quality long lasting materials that should give you years of trouble free operation and durable service. Before you unpack your new band saw, please, read completely this manual.

IMPORTANT!: it is of vital importance that you or any person that will operate this unit thoroughly read this manual.



WARNING!:

This machine is designed to cut food products and is by nature dangerous, if not used and maintained properly for optimum safety.

This equipment must be connected to a thermal connection, not use the equipment if it is not properly grounded.



The appliance **is not be used** by persons (including children) with reduced physical, sensory or mental capabilities, or lack of experience and knowledge, unless they have given supervision or instruction. Children being supervised not play with the appliance.



Never perform service, cleaning or maintenance on this unit while connected to a power source.



Never use hands or fingers to feed products to cut; or introduce hands in to the blade track area, within 4 " (four inches) close to the blade, while in operation.



Do not leave the machine unattended while in operation & turn it off when it is not being used.

II.- UNPACKING

While unpacking the machine take special care in removing these components to be assembled later. Make sure that all are accounted for *.

- 1 spare band saw (6)
- 1 spare fiber guide (17)
- 1 scrap pan (26)
- 1 carriage (8)
- 1 table assembly (5)
- 1 Last Cut Pusher (40 - some models only)
- 4 Rubber legs (33 - some models only)

*Note: for reference numbers see “Meat saw diagram for components” (central pages).

III.- INSTALLATION:

Before connecting to the power source follow these easy assembly and preparation steps. (Never execute these procedures with the cord plugged to the power source).

- 1.- Set the saw on a clean and level floor, using the leveling legs (28)
- 2.- Be sure that the pulleys (2 & 25) and blade (6) run free of objects.
- 3.- It is possible to assemble the table (5) directly, but in order to avoid blade (6) damage, we suggest to remove it, to do this, follow these easy steps.
 - A.- Open the head door (19) and the lower (right) door (23).
 - B.- Rotate-up the fiber or Zytel guide (17) (see fig. 1).
 - C.- Turn the tension handle (18) counter clock wise, until blade (6) is lose.
 - D.- Pull out the blade from the wheels (2 & 25), guides (15, 16 & 17) and scrapers (20).
- 4.- Now you can Install the table assy. (5), following these steps (see fig. 2):
 - A.- Be sure that the head door (19) and the right door (23) are still open.

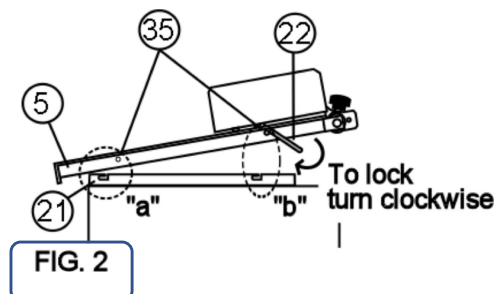
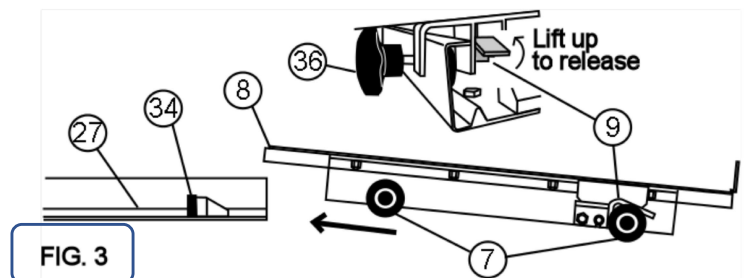
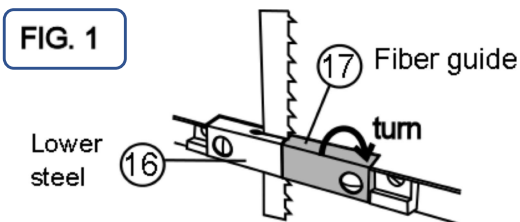

B.- Carefully take the table assy. (5), place it on the table base guides (21).

C.- First insert one rod on the base-slot as shown on **step " a "** (Fig. 2), then put the other rod, on the other slot as shown on **step " b "**.

D.- Assure the rods of the table assy. (35) firmly into the slots of the table base (21).

E.- Turn the handle (22) under the table (towards you), to lock the table assy (5).

5.- To Install the carriage (8) on its guide (27), the steps are as follow (see fig. 3)

A.- Take the carriage (8).

B.- Taking the picture of Fig 3 as reference, get the rear wheels (7) close to the carriage guide (27) and assure to put both wheels (7) into the guide.

C.- Move the carriage (8) all the way in, the carriage-lock (9) will engaged automatically. To take out the carriage, lift up the lock to release it and then pull the carriage completely.

Note: You can fix the carriage and avoid movement using the Stopper knob (36).

6.- Installing the saw blade (6).

A.- Be sure of the direction of the cut (**teeth must face down, see detail "a" on fig. 4**).

B.- Put the blade (6) on the wheels (2 & 25), into the guides (15,16 & 17) and into the scrapers(20).

C.- Turn the tension handle (18) clock wise until the red spot (1) is in the center of the hole, of the tension gauge housing (31).

D.- Turn the upper wheel (2) counter clock wise 2 or 3 revolutions by hand, **very slowly and with caution** to be sure everything is ok.

E.- Be sure the blade is correctly aligned (must have a separation of 1/32" against the pulley's edge. Fig 5).

Note: do not over tighten the blade, the excessive tension will cause overheat and the blade might brake with potential personal injury.

Note: check the power source of your facility, and be sure it matches the requirements of the unit, the voltage of the motor can be changed by a qualified electrician or authorized dealer.

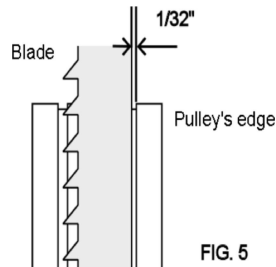
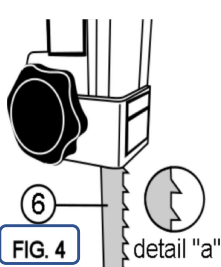

7.- Close all the doors

8.- Select the work place, and:

A.- Be sure that the surface is leveled and clean.

B.- If you need to level the meat saw, use leveling legs (28).

C.- Connect the saw to the power source (it must be close to the saw as much as possible).



WARNING!:

Never operate this machine while the doors are open. Serious injury may happen .

Before completing the electrical connection, verify the direction of movement of the band saw (6). When the on button is pressed, the band saw must moves from top to bottom in the sliding bar side (Fig. 5A). If the band saw moves from bottom to top, push the stop button and unplug the equipment. Interchange 2 of 3 in coming power supply wires (Fig. 5B).

Reconnect the meat saw to the power supply, turn it on and verify the direction of movement again. If the good operation is confirmed, then fix the connection to the power supply. If you have any question regarding to the connection of the equipment, contact to your authorized dealer. The above procedure only applies to meat saws with three phase connection.

Fig. 5A

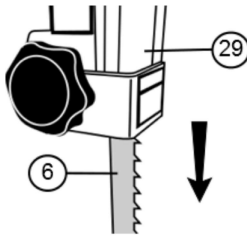
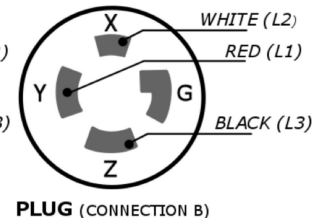
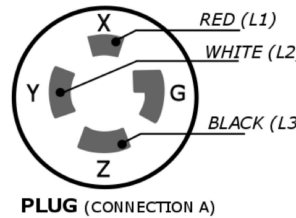

Fig. 5B



CAUTION!:

Unplug or disconnect the machine from the power supply before changing wires.

IV.- OPERATION

Do not use the equipment if it is not properly grounded.

Important: for the first time usage you must cut a couple of pounds of scrap clean product to clean the blade (6) of any dirt or foreign debris.

Normal operation of the saw:

- 1.- Select the desired thickness to cut, using the gauge plate assy (11).
- 2.- Put the product on the carriage (8)
- 3.-Turn on the machine (**do not leave machine unattended while in operation**).
Your saw is equipped with a thermo magnetic triple phase switch box, (which is the same for single phase) press the green button to start and the red button to turn off the power.
- 4.- Placing the product against the gauge plate (11) you can start to cut, it is recommended to work front face to the gauge plate, **once again, never put your hands or fingers close to the blade, serious personal injury may happen.**
- 5.- You may start to cut the product.



CAUTION!:

Turn off and disconnect the equipment when is not in use

SAFETY FEATURES

This Meat saw has special features to guarantee your own safety. Most of them are proximity switches (41) located in the equipment's main accesses, like head (19) and lower (23) doors. The other switch is located below of table assy (5). In all cases, the operation of the meat saw will stop immediately if any door is open or if the table assy is not correctly located at the time of normal operation.

Another extra device is the General interrupter (42), when is in OFF position, de-energizes the complete equipment even though is connected to the main power source (See Fig. 6).



CAUTION!:

Do not remove or customize any of the safety devices included in your Meat saw, this could cause malfunction or may represent a risk to your personal integrity. If you notice that any of these devices are not operating properly, please call to your authorized dealer

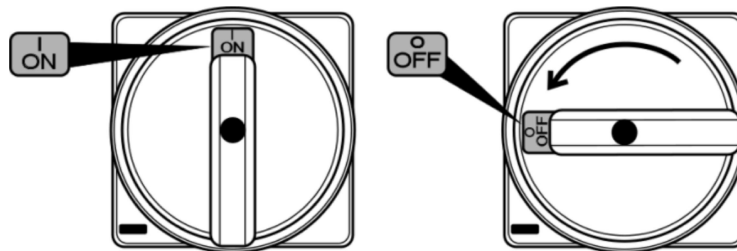

FIG. 6 MEAT SAW GENERAL INTERRUPTER

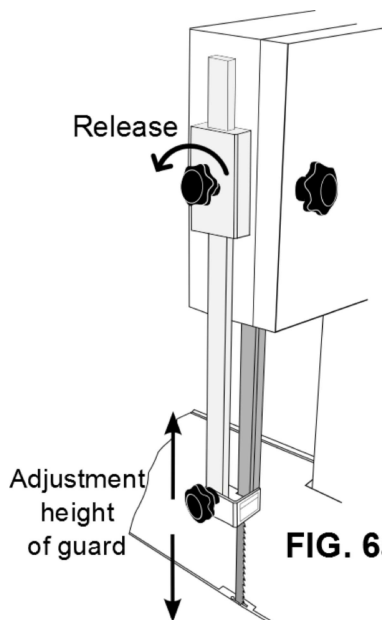

FIG. 6a BAND SAW GUARD

In addition to the mentioned devices, the meat saw comes with a band saw guard too. It is to prevent any unwanted contact from the band saw while the equipment is working even if the equipment is turned off due the band saw is dangerous by nature.

For adjusting the band saw guard, turn counterclockwise the superior handle (24) (Fig 6a) for releasing and adjusting the height enough to cut meat. Turn clockwise the superior handle to fix again the band guard saw.

If the meat saw is not been used, slide down the band saw guard until the table assy (5) for covering completely the band saw.

V.- KEY ELEMENTS IN CUTTING QUALITY PRODUCT:

1.- Do not force the cut against the blade (6).

2.- Be sure of using always sharp saw blades.

To know if you are still using a sharp blade, pay attention to the feel of the cut. If you have to force feed the product to cut into the blade then you need a new sharp blade, if the cut feels smooth and without much effort then your blade is still ok.

Note: if you need to replace it, follow the procedure described on INSTALLATION section.

3.- Keep clean and free of any product or scrap, the guides (15, 16 & 17), wheels (2 & 25) and cleaners (20), **never attempt any cleaning while the machine is connected to the power source.**

Note: it is not recommended to use re-sharpened blades because you will create more scrap in your product. And have a less efficient operation.

VI.- CLEANING



CAUTION!:

Always disconnect the machine from the power source before executing any service or maintenance

For the daily cleaning remove all the scrap of the machine with the scrap pan and a brush and then wash down the machine with a soft damp cloth or a soft brush with a mild detergent and then water. **Do not clean the machine with a water hose.**



CAUTION!:

Never use abrasives cleaners with chlorine, vinegar, acid o fibers, since they can affect the protective coating of the meat saw and its components and generate oxidation!.

Also it is recommended to do at least once a week a more through cleaning following this procedure:

1.- Remove the blade (see INSTALLATION section).

2.- Hold the upper wheel (2) with one hand and with your other hand turn the tension handle (18) counter clock wise until is completely out of the rod.

3.- Slide the upper wheel (2) down, out of the tension guides (32) and remove it, **be careful because it's heavy and if it falls may cause a personal injury.**

4.-The upper wheel (2) is assembled to the tension gauge assy. **(Fig.7)**. Disassemble the tension guide assy by removing the tension gauge pin (37) with your hands. This will let you to take out the tension gauge housing (31), tension gauge spring (39), the rod an indicator (1), and the upper wheel hanger (38). Clean these parts using a soft brush and a mild detergent, rinse with water.

Note: To guarantee the right operation of the equipment, keep lubricated the next elements:
Tension gauge Spring (39)
Rod and indicator (1)

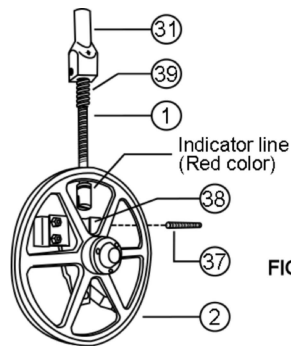

FIG. 7 ASSEMBLY OF UPPER WHEEL AND TENSION GUIDE

Assemble again, reversing the disassemble order, taking care that the red color painted side of the rod and indicator (1) face the hole at the tension gauge housing (31).

5.- Move the carriage (8) to your right until stop, then with your finger, lift the carriage-lock (9) and slide again to your right to remove the carriage from its guide (**see fig. 3**).

6.- Now remove the table assy.

7.- Now you can clean the saw easier. (We recommend to do this at least once a week) or often if you want it.

8.-After a very deep cleaning and drying of the machine, assemble back in reverse order following the steps on INSTALLATION section

STAINLESS STEEL SPECIAL CARE

This is a guideline of cleaning methods for stainless steel.

Requirement	Suggested Method
Routine cleaning of light soiling	Wash with Soap or detergent in warm clean water. Apply with a clean sponge, soft cloth or soft-fiber brush then rinse in clean water and dry.
Fingerprints	Use Detergent. Rinse with warm water. Dry totally
Watermarks	Use clean rinsing water, such as reasonable quality potable (tap) water. Drying marks may be avoided using an air blower or wiping with clean disposable wipes.
Grease marks	Use clean rinsing water , you could add white vinegar or soft water solution. Rinse with warm water again and dry.
Rust stains	Wash surface with CLR (calcium, lime & rust remover) type cleaner. Use not acid and recommended solution. Apply using a soft non-abrasive sponge. Rinse surface thoroughly with clean soft water after application.
Dirt and debris	Wash surface with a mild liquid soap. Apply using a soft, non-abrasive cloth. Rinse surface thoroughly with clean soft water.

VII. - MAINTENANCE.

1.- **Blade:** after cleaning the saw, check the sharpness of the blade, if it is not sharp enough replace it.

2.- **Fiber guide:** the purpose of this guide is to keep the blade straight to help you in the cut of the product, if you see the blade is not cutting in a straight path, or you see the clearance of groove in the fiber guide (17) to be more than 1/8 of an inch, it's time to replace it.

Also it is advisable to replace this component at least once every 2 months depending on work load.

To replace the fiber guide follow these steps (fig 8):

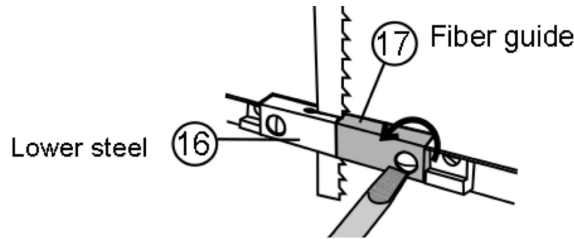

FIG. 8 REMOVING THE FIBER GUIDE

A.- Stop the machine and disconnect from the power source.

B.- Slide the carriage (8) all the way to the left.

C.- With a screwdriver remove the screw from its place and replace the used fiber guide (17) for a new one included as a spare part.

Note: it is recommended that an authorized dealer technician performs a complete maintenance at least once a year.

If the power cable is damaged, it must be replaced by your authorized technical service or qualified personnel to avoid risk of electric shock.

Parts to be careful to review and / or replace due that are subject to wear.

Part revision (Serviceable)	Frequency	Remarks
Band saw	Daily	When the cut is not fine. When the cutting noise is increasing.
Cleaners	Weekly	Cleaners must have contact with band and pulleys all the time, this will give a good performance to the equipment. In case of cleaners got damaged because of wear exceeds, replace them.
Pulley's ball bearing	Weekly	It is recommended to lubricate the pulley's ball bearing for an optimum performance.
Lower steel and fiber guide	Daily	It is recommended replacing if it resulted broken. A fiber guide damaged could tear and break the band saw causing poor cut quality.
Membranes (ON-OFF)	Daily	A membrane damaged allows moisture and product residues accumulation in button's structure. This is one of the reasons for equipment malfunction. If this happen, replace membrane immediately.
Gauge housing (Top pulley tension)	Daily	After cleaning, it is recommended to lubricate these components for an optimum performance.

VIII.- EQUIPMENT SPECIFICATION

A) ELECTRICAL SPECIFICATIONS (Depends on your equipment. See ID plate):.

Equipment	Voltage	Current	Frequency	Capacity
Meat Saw	115 V~	21 A	60 Hz	1,1 KW (1,5 HP)
	220 V~	11 A	50 ó 60 Hz	1,1 KW (1,5 HP)
	220 V3~	8.4 A	50 ó 60 Hz	2.2 KW (3 HP)

B) GENERAL DIMENSIONS.

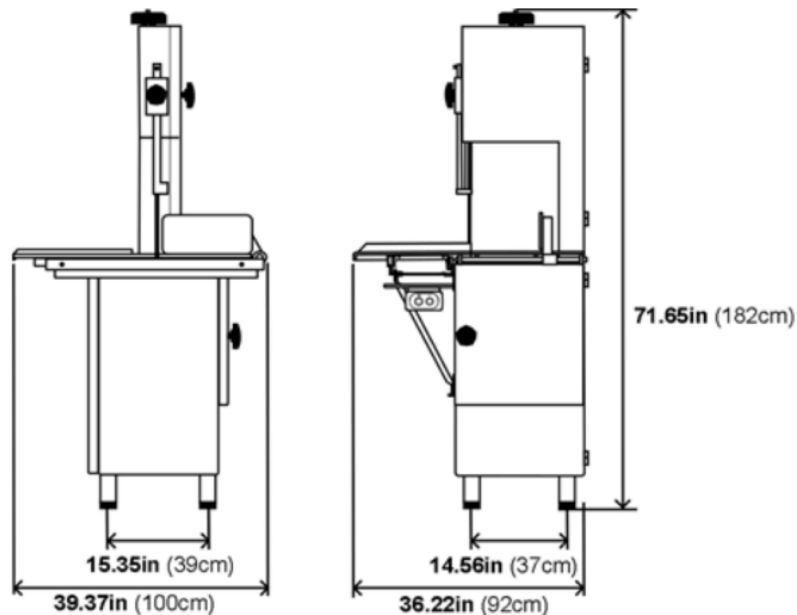

FIG. 9 MEATSAW GENERAL DIMENSIONS

IX. - ELECTRICAL DIAGRAM:

The electrical diagram for this unit is located inside the cabinet.



WARNING!:

The cabinet for this equipment must be opened by qualified personnel only. For any problem or doubt related to electric specifications and connections, please call to your authorized dealer.

X.- ELECTROMAGNETIC BRAKE (SOME MODELS ONLY):

Your meat saw may be equipped with an electromagnetic brake (see Fig. A1). If so, please refer to this information for proper operation and maintenance.

The brake motor is installed on the transmission system of the meat saw. It stops the motor and the saw band in less than 3 seconds.

A. OPERATION

The band saw stays locked when the meat saw is off. When the meat saw is turned on the brake releases the transmission pulley and the band saw can rotate.

If you turn the meat saw off the brake will lock the transmission pulley making that the motor stops.

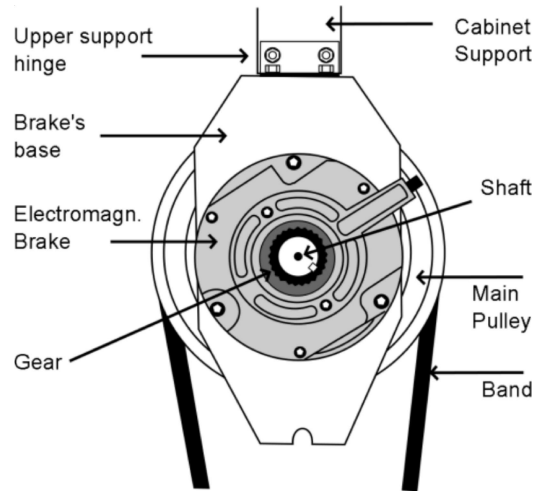

FIG. A1 ELECTROMAGNETIC BRAKE

B. ELECTRICAL CONNECTION

The brake is connected to the control box through a rectifier. (See Fig A2).

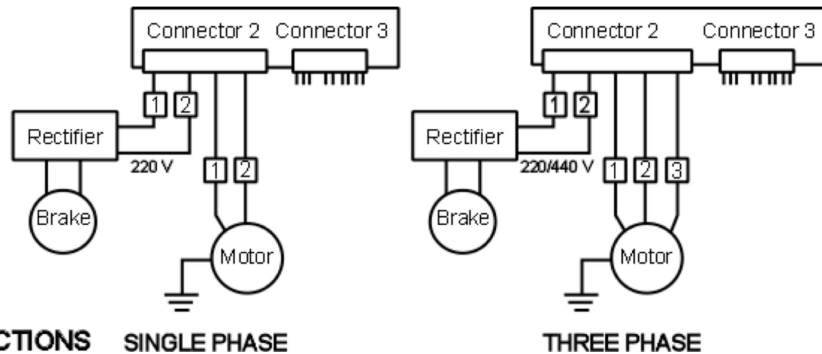

FIG. A2 CONNECTIONS SINGLE PHASE

THREE PHASE

C. STEPS FOR UNINSTALLING

1. Unplug the meat saw. Locate the brake on the transmission system.
2. Loosen the screws from the upper support.
3. Pull the brake and remove it from the shaft pulley.

D. STEPS FOR INSTALLING

1. Verify the concentricity between the friction plate and the rear plate (See Fig A3) before assembling the brake. For this operation refer to "Centering the Friction Plate" section.
2. If it is necessary adjust the Air Gap, refer to "Air gap adjustment" Section.
3. Mount the brake on the shaft pulley until all edges are aligned with the edge of the pulley.
4. Screw the upper support hinge and the base of the brake to the cabinet Support.

E. CENTERING THE FRICTION PLATE

The friction plate is aligned from factory, but in some cases, due to transportation or if the equipment is drastically moved, the friction plate could lose this alignment. If this happens, uninstall the brake and follow these steps to center it again.

1. Release the brake (**Fig A5**) turning clockwise the screw in the lever of brake's ring.
2. After this, the friction plate (cylinder shown in **Fig A3** at back side of brake), will freely move.
3. Use your hand to center the cylinder into the circumference.
4. Turn screw counter-clockwise to lock the friction plate and carefully install the brake again.

FIG. A3 CONCENTRICITY

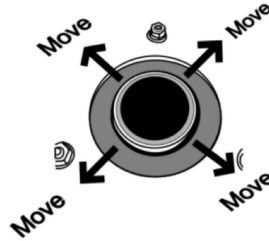
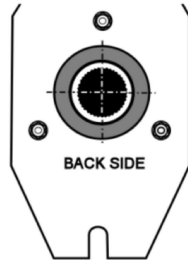

D. AIR GAP ADJUSTMENT

After a long time usage, the brake will need to be adjusted. Using a 5/32" allen wrench (included), turn the adjustment screws (see **Fig A4**) counterclockwise a quarter turn.

Turn the meat saw on and then turn it off to verify the braking time (less than 3 seconds). Turn a quarter turn more the screws if it is necessary.



IMPORTANT!:

The gap must be the same along the brake's circumference. A correct adjust will avoid overheating.

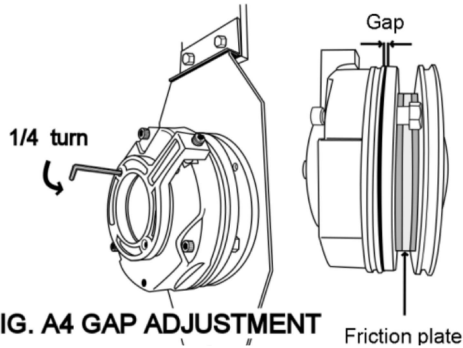

FIG. A4 GAP ADJUSTMENT

Friction plate



WARNING!:

Before a service and maintenance you must unplug the meat saw from the power supply.

E. MAINTENANCE

If the equipment requires a band saw adjustment, you will need to release the pulley. Use a 5/32" allen wrench (included) and turn the screw (see **Fig A5**) clockwise a whole turn. Complete service and screw back to previous position to lock the pulley again.

To release, turn clockwise

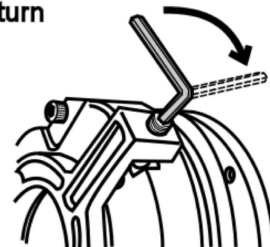

FIG. A5

If you have any doubt regarding the brake operation or installation, please contact your authorized dealer.

MEAT SAW DIAGRAM FOR COMPONENTS (SEE CENTRAL PAGES)

ITEM	DESCRIPTION	QTY
1	ROD & INDICATOR 1/2"	1
2	UPPER PULLEY	1
3	ADJUST SCREW	1
4	HEX NUT 3/8"	1
5	TABLE ASSY	1
6	BLADE (BAND SAW)	1
7	WHEEL (BIG ROLLER)	4
8	TABLE CARRIAGE	1
9	LOCK	2
10	MOTOR (NOT SHOWN)	1
11	GAUGE PLATE ASSY	1
12	ON/OFF INTERRUPTOR	1
13	POWER CORD	1
14	MOTOR PULLEY (NOT SHOWN)	1
15	UPPER SAW GUIDE	1
16	LOWER GUIDE (STEEL)	1
17	FIBER GUIDE	1
18	TENSION HANDLE	1
19	HEAD DOOR	1
20	WHEEL SCRAPER (CLEANER)	5
21	TABLE BASE	1
22	LEVER	1
23	LOWER DOOR (RIGHT)	1
24	HANDLE	2
25	LOWER PULLEY	1
26	PAN	1
27	CARRIAGE GUIDE	1
28	LEVELING LEGS	4
29	SLIDING BAR	1
30	BLADE GUARD	1
31	TENSION GAUGE HOUSING	1
32	TENSION GUIDES	2
33	RUBBER LEGS	(4)
34	STOPPER	2
35	TABLE ASSY RODS	2
36	CARRIAGE STOPPER KNOB	(1)
37	TENSION GAUGE PIN	1
38	UPPER WHEEL HANGER	1
39	TENSION GAUGE SPRING	1
40	LAST CUT PUSHER	(1)
41	INTERLOCK*	(1)
42	GENERAL INTERRUPTER*	1

(* Apply only for some models)



THANKS FOR READING THIS MANUAL. IF YOU HAVE ANY DOUBT REGARDING
THE OPERATION OF THIS MEAT SAW, PLEASE CONTACT TO YOUR PRO CUT
AUTHORIZED DEALER.