



KT-1000 ICE KUBE MACHINE

KT-1000 Ice Kube Machine

Models

- KDT-1000A KYT-1000A KDT-1000W KYT-1000W KDT-1000N KYT-1000N



Koolaire KT-1000
Ice Kube Machine on K570 Bin

Koolaire by Manitowoc ice machines are designed, developed and tested by Manitowoc engineers to provide great ice production, energy efficiency and reliable service at an affordable price.

Performance/Features/Benefits

- Produces up to 960 lbs (435 kg) of ice per day**
- Performance certified by the Air Conditioning, Heating and Refrigeration Institute (AHRI)
- Energy Efficient models - visit EnergyStar.gov to view all Energy Star qualifying models
- Highly efficient electro-less nickel plated copper evaporators made in Manitowoc WI, USA
- Simple operation - only one control, three positions ON/OFF/CLEAN
- High-Tech exterior with smudge and fingerprint resistant stainless-like finish
- Better for the environment. Uses R410A refrigerant which lowers global warming potential by 48%
- Backed by the industry's best Manitowoc distribution network and service agents

Built for Easy Sanitation

- Easy access front facing evaporator
- One-touch remedial cleaning; requires minimal interaction; just add chemical and let the machine do the rest. No ice removal from bin needed. (Use Manitowoc De-scaler and Sanitizer only)
- For detail cleaning; all food zone components removable by hand (no tools required). Fast and easy
- All white plastic interior, no exposed tubes or wires, smooth rounded corners for fast easy wipe downs
- The food zone is sealed from above and on the back of the door panel with commercial grade rubber gaskets
- Alpha San anti-microbial agent molded in selected components
- **Available LuminIce II Virus and Bacteria Inhibitor**- Controls viruses, bacteria, mold and yeast within the food zone to keep the machine clean longer (order K00520 for 22" & 30" and K00521 for 48" machines)

**based on 70F air / 50F water

Ice Machine Electric

203-208V / 60Hz / 1Ph

Minimum circuit ampacity:

- Air-cooled: 10.8
- Water-cooled: 10.1
- Remote Air-cooled: 9.3

Maximum fuse size:

- Air-cooled: 15 amps
- Water-cooled: 15 amps
- Remote Air-cooled: 15 amps

Specifications

Operating Limits:

- Ambient Temperature Range: 40° to 110° F (4.4° to 43.3° C)
- Water Temperature Range: 40° to 90° F (4.4° to 32.2° C)
- Water Pressure Ice Maker Water In: Min. 20 psi (137.9 kPa) Max. 80 psi (551.1 kPa)

BTU Per Hour:

13,300 (average) and 16,300 (peak)

Refrigerant:

R410A CFC - Free
Lowers global warming by 48%

Ice Shape



HALF KUBE

3/8" x 1 1/8" x 7/8"
(.95 x 2.86 x 2.22 cm)

❄️ = 100%
⬇️



KUBE

7/8" x 7/8" x 7/8"
(2.22 x 2.22 x 2.22 cm)

❄️ = 100%
⬇️



KT1000 on K-570 Storage Bin

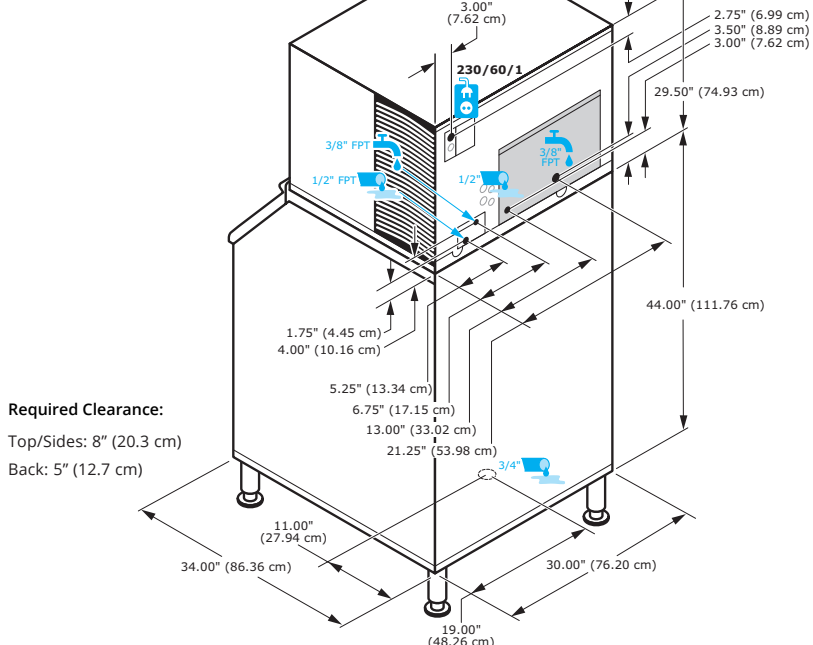

Required Clearance:
Top/Sides: 8" (20.3 cm)
Back: 5" (12.7 cm)

Space-Saving Design



	KT1000 K-570
Height	79.5"
Width	202.93 cm
Width	30.00"
Width	76.2 cm
Depth	34.00"
Depth	86.30 cm
Bin	532 lbs.
Storage	241 kgs.

Measurements with bin legs at 6.00" (15.24cm).
Adjustable bin legs 6.00" to 8.00" (15.24cm to 20.32cm). Bin capacity is based on 90% of the volume x 33 lbs/ft³ average density of ice.

Water cooled condenser water usage/100 lbs. or 45.5 Kg. of ice: 140 gals. / 530L.

Specifications

	Model	Ice Shape	Ice Production 24 Hours		Power Usage kWh/100 lbs. @90°Air/70°F	Potable Water Usage/100 lbs. 45.4 kgs. of Ice
			70°/ 50°F 21°/ 10°C	90°/ 70°F 32°/ 21°C		
AIR COOLED	KDT-1000A	kube	890 lbs.	680 lbs.	5.35	20 Gal. 75.7 L
			404 kgs	308 kgs		
AIR COOLED	KYT-1000A	half-kube	960 lbs.	775 lbs.	4.9	20 Gal. 75.7 L
			435 kgs	352 kgs		
WATER COOLED	KDT-1000W	kube	835 lbs.	720 lbs.	4.35	20 Gal. 75.7 L
			379 kgs	327 kgs		
WATER COOLED	KYT-1000W	half-kube	860 lbs.	730 lbs.	4.25	20 Gal. 75.7 L
			390 kgs.	331 kgs		
REMOTE COOLED	KDT-1000N	kube	860 lbs	735 lbs	4.94	20 Gal. 75.7 L
			390 kg	333 kg		
REMOTE COOLED	KYT-1000N	half-kube	905 lbs	760 lbs	5.0	20 Gal. 75.7 L
			411 kg	345 kg		

Order ice machine and bin separately.
For "N" models order Manitowoc JCT1200-261 remote condenser.

Shipping Weight:

Air-cooled: 202 lbs (92 kg)
Water-cooled: 206 lbs (93 kg)
Remote Air-cooled: 246 lbs (112 kg)

COMMERCIAL WARRANTY

ICE MAKER	EVAPORATOR	COMPRESSOR
3	5	5
YEAR	YEAR	YEAR PARTS
PARTS AND LABOR	PARTS AND LABOR	3 YEAR LABOR

KT-1000 ICE KUBE MACHINE

Accessories

Dispenser Bin Thermostat Kit reduces condensation when used with dispensers.



Top Air Discharge Kit convert air flow to rear in-take / top exhaust.

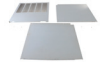

Arctic Pure Plus® Water Filters reduce sediments and chlorine contaminants down to .5 microns. Use with a Pre-filter is recommended.



Luminex II Virus and Bacteria Inhibitor controls viruses and bacteria inside the ice machine



Manitowoc Ice reserves the right to make changes to the design or specifications without prior notice.

2110 South 26th Street
Manitowoc, WI 54220

Tel: 1.920.682.0161
Fax: 1.920.683.7589

www.kool-aire.com
5205H 06/22