



KT-1000 ICE KUBE MACHINE

# KT-1000 Ice Kube Machine

## Models

- KDT-1000A  KYT-1000A  KDT-1000W  KYT-1000W  KDT-1000N  KYT-1000N



Koolaire KT-1000  
Ice Kube Machine on K570 Bin

Koolaire by Manitowoc ice machines are designed, developed and tested by Manitowoc engineers to provide great ice production, energy efficiency and reliable service at an affordable price.

### Performance/Features/Benefits

- Produces up to 960 lbs (435 kg) of ice per day\*\*
- Performance certified by the Air Conditioning, Heating and Refrigeration Institute (AHRI)
- Energy Efficient models - visit EnergyStar.gov to view all Energy Star qualifying models
- Highly efficient electro-less nickel plated copper evaporators made in Manitowoc WI, USA
- Simple operation - only one control, three positions ON/OFF/CLEAN
- High-Tech exterior with smudge and fingerprint resistant stainless-like finish
- Better for the environment. Uses R410A refrigerant which lowers global warming potential by 48%
- Backed by the industry's best Manitowoc distribution network and service agents

### Built for Easy Sanitation

- Easy access front facing evaporator
- One-touch remedial cleaning; requires minimal interaction; just add chemical and let the machine do the rest. No ice removal from bin needed. (Use Manitowoc De-scaler and Sanitizer only)
- For detail cleaning; all food zone components removable by hand (no tools required). Fast and easy
- All white plastic interior, no exposed tubes or wires, smooth rounded corners for fast easy wipe downs
- The food zone is sealed from above and on the back of the door panel with commercial grade rubber gaskets
- Alpha San anti-microbial agent molded in selected components
- **Available LuminIce II Virus and Bacteria Inhibitor**- Controls viruses, bacteria, mold and yeast within the food zone to keep the machine clean longer (order K00520 for 22" & 30" and K00521 for 48" machines)

\*\*based on 70F air / 50F water

## Ice Machine Electric

203-208V / 60Hz / 1Ph

### Minimum circuit ampacity:

Air-cooled: 10.8  
Water-cooled: 10.1  
Remote Air-cooled: 9.3

### Maximum fuse size:

Air-cooled: 15 amps  
Water-cooled: 15 amps  
Remote Air-cooled: 15 amps

## Specifications

### Operating Limits:

- Ambient Temperature Range: 40° to 110° F (4.4° to 43.3° C)  
Water Temperature Range: 40° to 90° F (4.4° to 32.2° C)
- Water Pressure Ice Maker Water In: Min. 20 psi (137.9 kPa) Max. 80 psi (551.1 kPa)

### BTU Per Hour:

13,300 (average) and 16,300 (peak)

### Refrigerant:

R410A CFC - Free  
Lowers global warming by 48%

## Ice Shape



### HALF KUBE

3/8" x 1 1/8" x 7/8"  
(.95 x 2.86 x 2.22 cm)

❄️ = 100%  
⬇️



### KUBE

7/8" x 7/8" x 7/8"  
(2.22 x 2.22 x 2.22 cm)

❄️ = 100%  
⬇️



## KT1000 on K-570 Storage Bin

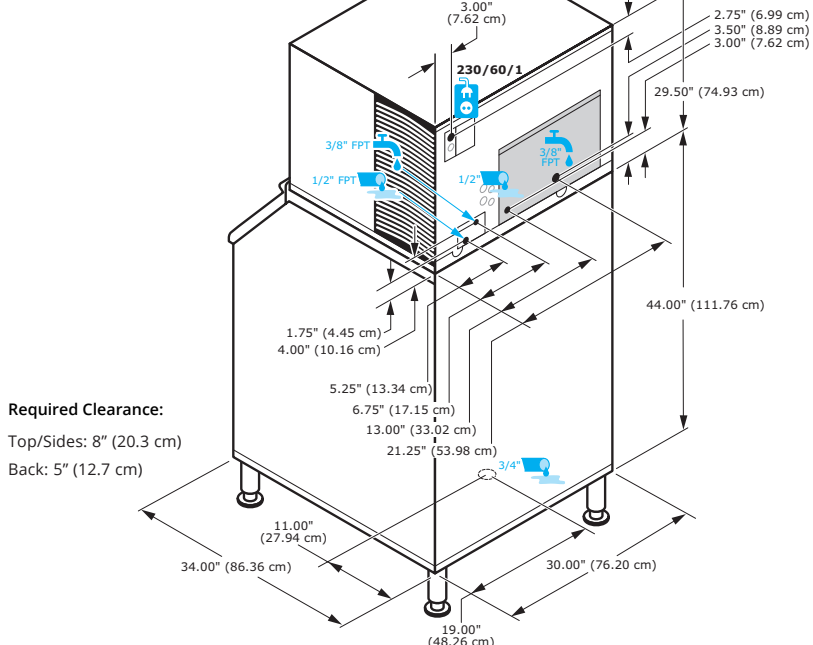

## Space-Saving Design



KT1000  
K-570

Height	79.5"
Width	202.93 cm
Depth	34.00"
Bin Storage	86.30 cm
Bin	532 lbs.
Storage	241 kgs.

Measurements with bin legs at 6.00" (15.24cm). Adjustable bin legs 6.00" to 8.00" (15.24cm to 20.32cm). Bin capacity is based on 90% of the volume x 33 lbs/ft<sup>3</sup> average density of ice.

KT-1000 ICE KUBE MACHINE

## Specifications

	Model	Ice Shape	Ice Production 24 Hours		Power Usage kWh/100 lbs. @90°Air/70°F	Potable Water Usage/100 lbs. 45.4 kgs. of Ice
			70°/ 50°F 21°/ 10°C	90°/ 70°F 32°/ 21°C		
AIR COOLED	KDT-1000A	kube	890 lbs.	680 lbs.	5.35	20 Gal. 75.7 L
			404 kgs	308 kgs		
AIR COOLED	KYT-1000A	half-kube	960 lbs.	775 lbs.	4.9	20 Gal. 75.7 L
			435 kgs	352 kgs		
WATER COOLED	KDT-1000W	kube	835 lbs.	720 lbs.	4.35	20 Gal. 75.7 L
			379 kgs	327 kgs		
WATER COOLED	KYT-1000W	half-kube	860 lbs.	730 lbs.	4.25	20 Gal. 75.7 L
			390 kgs.	331 kgs		
REMOTE COOLED	KDT-1000N	kube	860 lbs	735 lbs	4.94	20 Gal. 75.7 L
			390 kg	333 kg		
REMOTE COOLED	KYT-1000N	half-kube	905 lbs	760 lbs	5.0	20 Gal. 75.7 L
			411 kg	345 kg		

Order ice machine and bin separately.

For "N" models order Manitowoc JCT1200-261 remote condenser.

### Shipping Weight:

Air-cooled: 202 lbs (92 kg)  
Water-cooled: 206 lbs (93 kg)  
Remote Air-cooled: 246 lbs (112 kg)



## Accessories

**Dispenser Bin Thermostat Kit** reduces condensation when used with dispensers.



**Top Air Discharge Kit** convert air flow to rear in-take / top exhaust.



**Arctic Pure Plus® Water Filters** reduce sediments and chlorine contaminants down to .5 microns. Use with a Pre-filter is recommended.



**Luminex II Virus and Bacteria Inhibitor** controls viruses and bacteria inside the ice machine



Manitowoc Ice reserves the right to make changes to the design or specifications without prior notice.