

Replacement Parts for 1/2" Swivel Stem Kits

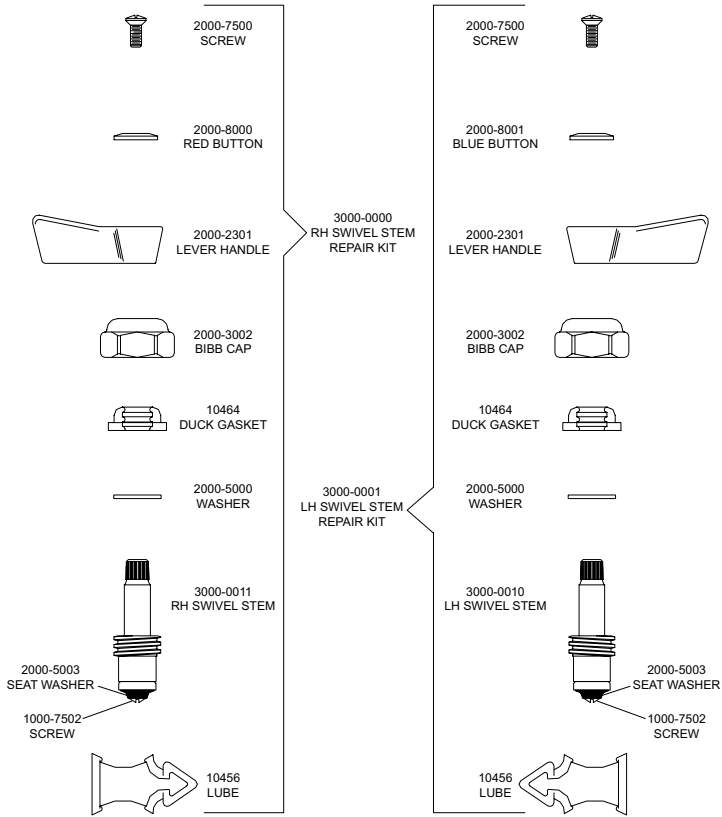

FISHER
MANUFACTURING COMPANY
PO BOX 60, TULARE, CA 93275
(800)421-6162, FAX: (800)832-8238
www.fisher-mfg.com

PART NO. 44156

REV. A

FISHER
FISHER MANUFACTURING COMPANY

1/2" Swivel Stem Kits Product Installation Guide

Since 1936, Fisher Manufacturing Company has manufactured heavy-duty, high quality plumbing products and hardware specialties for the food service industry. For three generations, the Fisher family has adhered to a strict dedication of and overall value. When you install Fisher products... you install the best. Our hardware is manufactured with the standardization of internal mechanisms. All chrome plating is triple plated copper, nickel and chrome for durability. Every piece of equipment we make is rigorously tested in both our modern in-house testing center and in actual field situations under extreme conditions. Every detail is thoroughly checked. Before we make our products available to you, they pass each and every test. You get proven performance. Guaranteed.

Limited One Year Warranty

Fisher Manufacturing Company warrants its products and parts thereof (except as noted below) against defects in materials or workmanship for a period of one year after the date of original purchase. During this period Fisher Manufacturing Company will replace a defective product or part without charge to you, provided that the entire product is delivered to Fisher Manufacturing Company. All transportation and insurance charges for shipping the product to and from Fisher Manufacturing Company must be borne by you. Charges for transportation and insurance may, at the option of Fisher Manufacturing Company, be refunded depending upon our investigation of the warranty claim. This warranty does not cover external finish (except at date of original purchase) or labor costs not specifically authorized by Fisher Manufacturing Company.

A full and complete copy of our One Year limited warranty is available upon request.

WARNING:

Proposition 65 requires that we provide you with the following notice: "This product Contains A Chemical Known To The State Of California To Cause Birth Defects Or Other Reproductive Harm."



3000-0000 - RH Swivel Stem Repair Kit
3000-0001 - LH Swivel Stem Repair Kit

KEEP THIS MANUAL FOR FUTURE REFERENCE



ANSI/A112.18.1M, ANSI/NSF 61.9

FISHER MANUFACTURING COMPANY - TOLL FREE: 800-421-6162 FAX: 800-832-8238

www.fisher-mfg.com

Replacement Parts for 1/2" Swivel Stem Kits

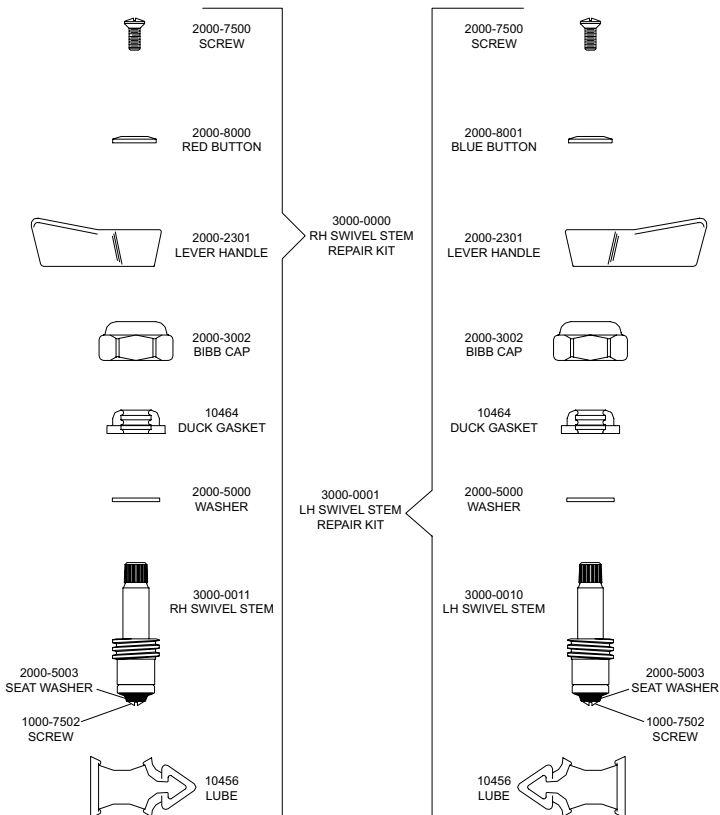

FISHER
MANUFACTURING COMPANY
PO BOX 60, TULARE, CA 93275
(800)421-6162, FAX: (800)832-8238
www.fisher-mfg.com

PART NO. 44156

REV. A

FISHER
FISHER MANUFACTURING COMPANY

1/2" Swivel Stem Kits Product Installation Guide

Since 1936, Fisher Manufacturing Company has manufactured heavy-duty, high quality plumbing products and hardware specialties for the food service industry. For three generations, the Fisher family has adhered to a strict dedication of and overall value. When you install Fisher products... you install the best. Our hardware is manufactured with the standardization of internal mechanisms. All chrome plating is triple plated copper, nickel and chrome for durability. Every piece of equipment we make is rigorously tested in both our modern in-house testing center and in actual field situations under extreme conditions. Every detail is thoroughly checked. Before we make our products available to you, they pass each and every test. You get proven performance. Guaranteed.

Limited One Year Warranty

Fisher Manufacturing Company warrants its products and parts thereof (except as noted below) against defects in materials or workmanship for a period of one year after the date of original purchase. During this period Fisher Manufacturing Company will replace a defective product or part without charge to you, provided that the entire product is delivered to Fisher Manufacturing Company. All transportation and insurance charges for shipping the product to and from Fisher Manufacturing Company must be borne by you. Charges for transportation and insurance may, at the option of Fisher Manufacturing Company, be refunded depending upon our investigation of the warranty claim. This warranty does not cover external finish (except at date of original purchase) or labor costs not specifically authorized by Fisher Manufacturing Company.

A full and complete copy of our One Year limited warranty is available upon request.

WARNING:

Proposition 65 requires that we provide you with the following notice: "This product Contains A Chemical Known To The State Of California To Cause Birth Defects Or Other Reproductive Harm."



3000-0000 - RH Swivel Stem Repair Kit
3000-0001 - LH Swivel Stem Repair Kit

KEEP THIS MANUAL FOR FUTURE REFERENCE



ANSI/A112.18.1M, ANSI/NSF 61.9

FISHER MANUFACTURING COMPANY - TOLL FREE: 800-421-6162 FAX: 800-832-8238

www.fisher-mfg.com

Installation Instructions for 1/2" Swivel Stem Kits

BE SURE TO CHECK WITH YOUR LOCAL DEPARTMENT HAVING JURISDICTION REGARDING BACKFLOW PREVENTION

Installation Notes:

- Be sure to shut off water supply before beginning.
- Use pipe thread sealant such as PST on all threaded joints.
- Check the packaging for missing items BEFORE beginning installation. If items are missing, contact your supplier.

Tools Required for Installation

- Medium Sized Crescent Wrench
- Screwdriver

Package Contents:

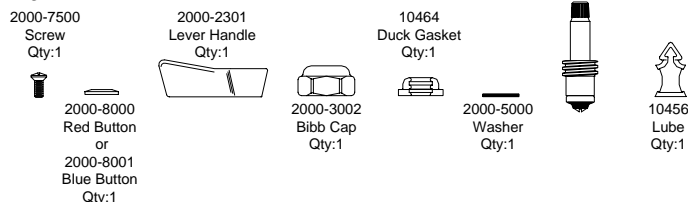

Installation Instructions

1. Turn off the water supply.
2. Remove the bibb cap (see Fig.1) by turning it counterclockwise (May require crescent wrench)
3. Lift bibb cap, remove the swivel stem
4. Insert new swivel stem valve (see Fig.2) into the control valve body inlet. Make sure swivel stem valve is closed.
5. Place the new washer and duck gasket over the swivel stem. Place new bibb cap over the swivel stem and tighten securely.
6. Place lever handle on the spline end of swivel stem (recommend at 7:30 and 5:30 position), set the red or blue button on top of the lever handle, insert screw and tighten.
7. Turn on the water supply and check for leaks

Installation Instructions for 1/2" Swivel Stem Kits

BE SURE TO CHECK WITH YOUR LOCAL DEPARTMENT HAVING JURISDICTION REGARDING BACKFLOW PREVENTION

Installation Notes:

- Be sure to shut off water supply before beginning.
- Use pipe thread sealant such as PST on all threaded joints.
- Check the packaging for missing items BEFORE beginning installation. If items are missing, contact your supplier.

Tools Required for Installation

- Medium Sized Crescent Wrench
- Screwdriver

Package Contents:

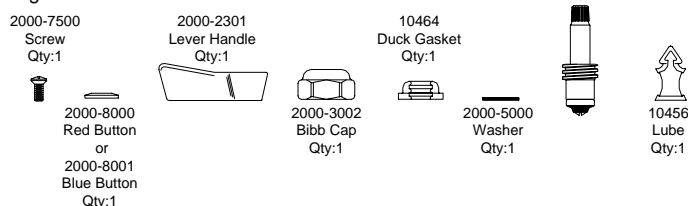

Installation Instructions

1. Turn off the water supply.
2. Remove the bibb cap (see Fig.1) by turning it counterclockwise (May require crescent wrench)
3. Lift bibb cap, remove the swivel stem
4. Insert new swivel stem valve (see Fig.2) into the control valve body inlet. Make sure swivel stem valve is closed.
5. Place the new washer and duck gasket over the swivel stem. Place new bibb cap over the swivel stem and tighten securely.
6. Place lever handle on the spline end of swivel stem (recommend at 7:30 and 5:30 position), set the red or blue button on top of the lever handle, insert screw and tighten.
7. Turn on the water supply and check for leaks

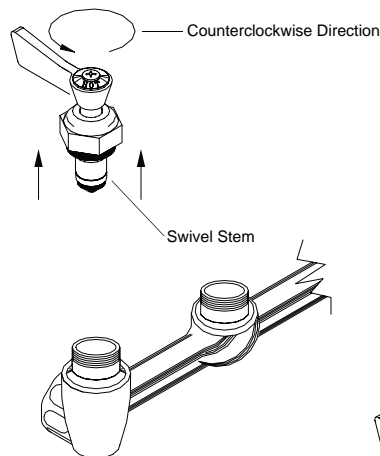

Fig.1 (Removal of Swivel Stem)

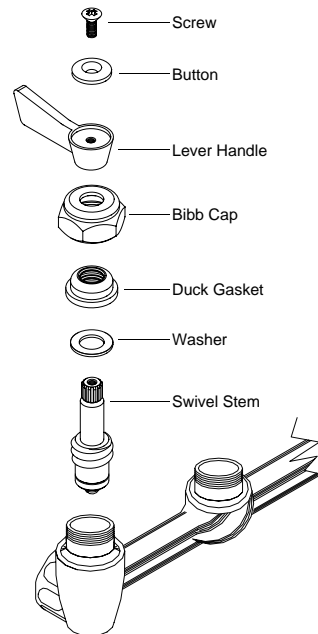

Fig.2 (Installation of Swivel Stem)

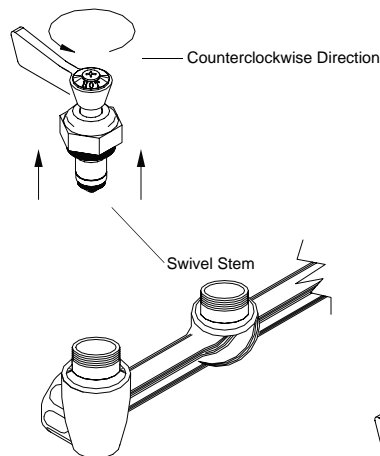

Fig.1 (Removal of Swivel Stem)

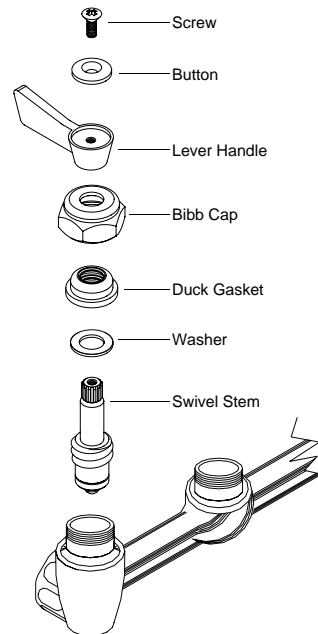

Fig.2 (Installation of Swivel Stem)