

BLACK◆DIAMOND®

Project Name: _____

Location: _____

Item #: _____

Qty: _____

Black Diamond Chest Freezer, Two Glass Doors, 15.7 cu ft, in White

BDCF-15-CG



Elevate your frozen storage with the Black Diamond Sliding Glass Door Chest Freezer, designed for commercial use in convenience stores and bakeries. Featuring tempered glass doors, it ensures durability and visibility. With a 15.7 cubic feet capacity, it accommodates a wide range of frozen foods. Maintains temperatures from -4° to 3.2°F. Includes a manual temperature controller and R290 refrigerant for efficiency. Easy cleaning with a drain plug and manual defrost system.

FEATURES AND CONSTRUCTION

- 15.7 cu ft capacity perfect for storing ice cream, frozen meals, and snacks
- 1/5 horsepower side-mounted compressor for efficient cooling
- Constructed with durable procoated steel and tempered glass
- Temperature range from -4° to 3.2°F for optimal preservation
- Utilizes environmentally friendly R290 refrigerant for efficient cooling
- Operates on 115V with a NEMA-5-15P plug for convenience
- Sliding glass doors for easy access and product visibility
- Includes five baskets for organized storage
- Features integrated locks for added security
- LED interior lighting enhances product display

ELECTRIC

115V / 60Hz / 1Ph
Cord Length (Inches): 70"
Plug Type: NEMA 5-15P
Cord set included

NEMA 5-15P



3RD PARTY APPROVALS



Intertek



Intertek

WARRANTY (USA / CANADA)

1 Year Warranty on Parts & Labor, 1 Year Warranty on Compressor

Contact Admiral Craft Equipment for details at 1-877-672-7740



STORAGE CAPACITY

- Cubic Feet: 15.7 cu. ft.

TEMPERATURE

- Holding Temperature (Fahrenheit): -4° - 3.2°

These models are designed to operate in an environment where temperature and humidity do not exceed 75°F (24°C) and 55% relative humidity

Black Diamond Chest Freezer, Two Glass Doors, 15.7 cu ft

BDCF-15-CG

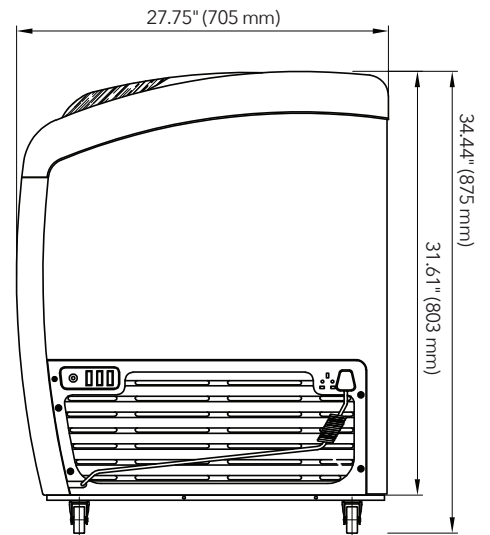
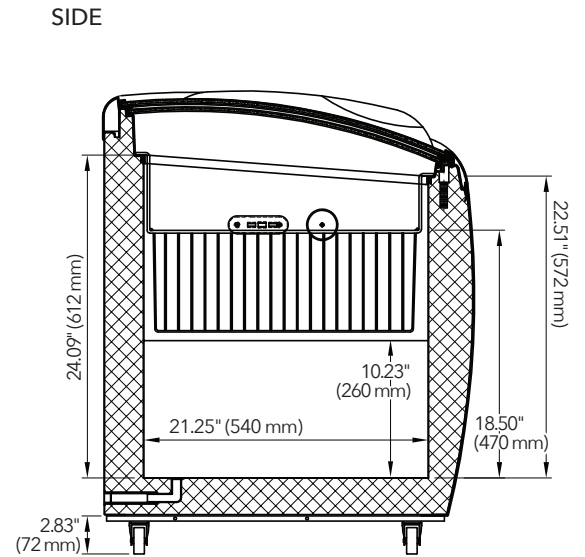
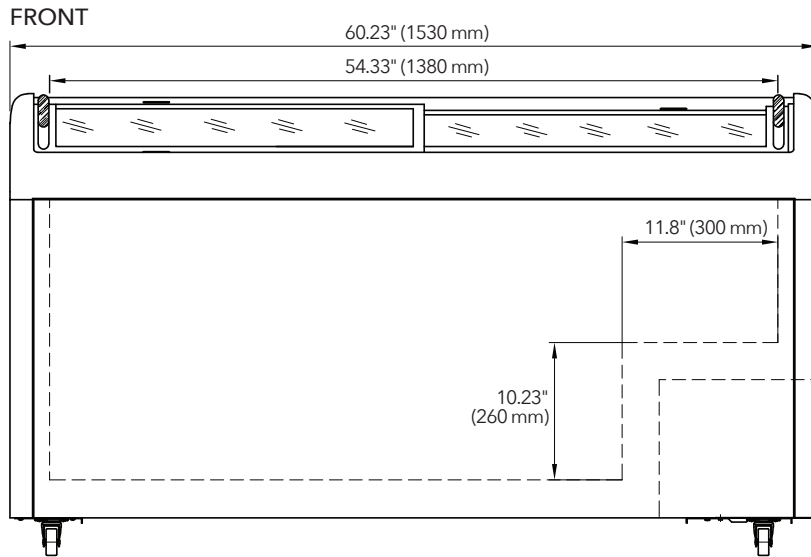

Chest

Doors	Baskets Included	Casters	Refrigerant	Amps	HP	Wattage	Assembled Dimensions (in)	Item Weight (lbs)	Shipping Weight (lbs)
2	5	4	R290 3.17 oz	2.2A	1/5	350W	27.75" x 60.23" x 34.44"	172.0	196.2

Due to periodic changes in designs, methods, procedures, policies and regulations, the specifications contained in this document are subject to change without notice. While we exercise good faith efforts to provide information that is accurate, we are not responsible for errors or omissions in information provided or conclusions reached as a result of using the specifications. By using the information provided, the user assumes all risks in connection with such use.