

Operation Manual

Glastender®

A Family Company Manufacturing
In The USA Since 1969

SELF-CONTAINED FRONT SERVICED COOLERS AND FROSTERS

This manual is specific to the following front-serviced coolers:

- C1FB, C2FB, C1FL, CP1FB, CP1FL, C1FU, CS1FB, F1FB, F1FL
- KC - beginning with SN 290187703 and manufactured April 15, 2019 and after



C1FB60 with compressor right, stainless doors/drawers, and stainless top



C1FL60 with compressor left, stainless doors and top, and stainless pull tab handle

Glastender, Inc. · 5400 North Michigan Road · Saginaw, MI · 48604-9780
800.748.0423 · 989.752.4275 · Fax 989.752.4444 · <https://glastender.com>



Index

COOLER SERIAL NUMBER INFORMATION	COVER
DIGITAL CONTROLLER OPERATION	1 - 2
INSTALLATION	
Introduction	3
Utility Requirements and Connections	3
Uncrating and Start-Up Instructions	3
Sealing Vertical Door Cooler to Floor Instructions	3
Cooler Installation Checklist	4
Beer Tower Installation	4
Cleaning Instructions	5
SPECIFICATIONS	
CS1FB Anti-Tip Bracket Installation	6
Wiring Diagrams	7-9
SERVICE AND PARTS	
Terms and Conditions	10
Warranty	11 - 12

For replacement part information, visit:
<https://www.glastender.com/support/parts>

WARNING: Components shall be replaced with like components only. Service shall be done by factory authorized service personnel only, so as to minimize the risk of possible ignition due to incorrect parts or improper service.

Digital Controller Operation

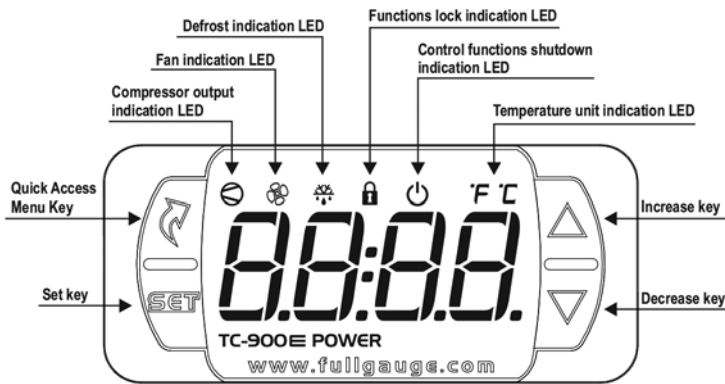

Setting Desired Temperature

The operating temperature is preset at the factory according to the table below and can be adjusted up or down within the limits shown. Press the Quick Access Menu Key 6 times until SP appears on the display. Press the Set key. Use the increase or decrease keys to modify the value. Press the Set key to confirm.

For units manufactured prior to June 2021, turning digital controller ON/OFF: All cooler models can be turned ON/OFF by pressing and holding the Quick Access menu key for 5 seconds. When the digital controller is off, the message OFF is displayed alternating with the temperature.



	Factory Settings		Range of Adjustment	
	Set Point	Operating Range†	Minimum Set Point	Maximum Set Point
Standard Cooler Setting	34° F	34° F to 39° F	33° F	65° F
White Wine	50° F	50° F to 55° F	33° F	65° F
Red Wine	60° F	60° F to 65° F	33° F	65° F
Froster Setting	12° F	12° F to 20° F	12° F	35° F

† Adjusting the factory set point will also adjust the operating range by the same amount

Digital Controller Operation

Automatic Defrost

Each time the door is opened, moisture from the outside air enters the cabinet. Consequently, frost builds up on the evaporator coil over time. To eliminate this buildup and keep the unit running efficiently, Glastender coolers and frosters are programmed to automatically defrost 4 or 3 times each day, respectively. Under typical operating conditions, the automatic defrost process will not interfere with the ability of the F1F frosters to hold specialty cocktail ice.

F1F frosters have a manually-activated, 6-hour defrost

Over time, which varies depending on the level of humidity in the air, the F1F frosters will require a manually-activated, 6-hour defrost cycle to completely free the evaporator drain pan of frost buildup. Activate this defrost cycle by pressing the round button below the digital controller. The controller display will alternate between ECO and ON. An in-progress, 6-hour defrost cycle can be canceled at any time by pressing the round button.



Activate the 6-hour defrost cycle at the close of business, at least once per week. The froster will automatically resume normal operation six hours later. Please note, specialty cocktail ice cannot be held during this 6-hour defrost cycle.

Holding specialty cocktail ice in an F1F froster

The F1F family of frosters will hold specialty cocktail ice by following these operational guidelines:

Set the digital controller to a temperature set point of 12° F.

Keep the ice in sealed plastic bags or sealed containers.

Once per week, remove all specialty cocktail ice and manually activate the 6-hour defrost cycle by pressing the round button below the digital controller.

If specialty ice melting is observed while following the above guidelines, then it may be necessary to manually activate the 6-hour defrost cycle more than once per week.

Digital Controller Trouble Shooting Error Codes

If the digital controller display shows an Err 1 or Err 3 error code, this is likely the result of disconnected digital controller wires. These wires are commonly disconnected for service and maintenance. Please verify controller wires are connected before calling for service, because service calls to reconnect the controller are not covered by the factory warranty.

Self Contained Coolers Two Zone Models

If the second character of the model number is a “2”, then two separate refrigeration zones are programmed at the factory. EXAMPLE C2FB60.

The door or zone closest to the condenser cover must always be the colder compartment. If the condenser cover and controller are on the left end, then the left door(s) or zone will be the cold side. The right compartment must be set for a minimum of 8°F warmer. The thermostat on the left will control the refrigeration zone on the left. The thermostat on the right will control the zone on the right.

CODE	POSSIBLE CAUSES	RECOMMENDED ACTION
Err 1	Temperature sensing probe wires disconnected from digital controller	Reconnect wires, see wiring diagram provided in operation manual
Err 3	Defective temperature sensing probe	Call for service
Athi	Dirty condenser coil	Clean condenser coil
	Refrigeration system needs service	Call for service
RELo	Refrigeration system needs service	Call for service
AC1	Dirty condenser coil	Clean condenser coil
	Refrigeration system needs service	Call for service
AC2	Dirty condenser coil	Clean condenser coil
	Refrigeration system needs service	Call for service

Installation

INTRODUCTION

This manual describes the operational features of the self-contained coolers listed on the front of this manual. Please review this information before attempting installation and operation.

Long term, trouble-free service will follow if good housekeeping and maintenance procedures are followed. Thank you for selecting Glastender, Inc. products.

UTILITY REQUIREMENTS AND CONNECTIONS

- **Electrical:** 120 Volt AC, 1 Phase, 60 Hz. A separate 15 Amp circuit is recommended. A 6-foot grounded cord and plug is included with self-contained models.
- **Plumbing:** Automatic condensate evaporator is included. No drain connection required.

UNCRATING AND START-UP INSTRUCTIONS

Caution - This Refrigerator contains Flammable R290 Refrigerant. When moving and handling this equipment take care not to damage the refrigerant tubing or components.

All models are shipped in one carton. These steps should be followed:

1. If legs or casters are included:
 - Legs - install threaded legs into receiving holes and turn until tight to the flat surface.
 - Casters - attach to base with provided bolts.
2. Unwrap power cord from base if included.
3. Position unit and level and/or seal as required (see page 4 and 5).
4. All units intended for draft beer must be plumbed to an external drain. On self-contained models with draft beer and a factory installed finished top, the beer tower drain pan is plumbed through the cabinet and stubs out in the 3" space below the compressor compartment. Connection to an external drain must be made from that point.
5. Place shelves in desired location.
6. Plug into 115 volt AC outlet.
7. Load with bottles or cans and allow time for products to cool.
8. Your Glastender equipment is now ready for use.

SEALING VERTICAL DOOR COOLER TO FLOOR

To establish proper sanitation operation and to comply with NSF & health codes, the cooler base must be sealed to the surface to which it is mounted using an NSF listed sealant. Place a bead of sealant along outer edges of the base and remove any excessive amount. Make sure there are no gaps in the sealant as the intent is to prevent liquid spillage from adjacent surfaces from passing under inaccessible portions of the equipment. This sealing procedure does not apply to models that include legs or casters.

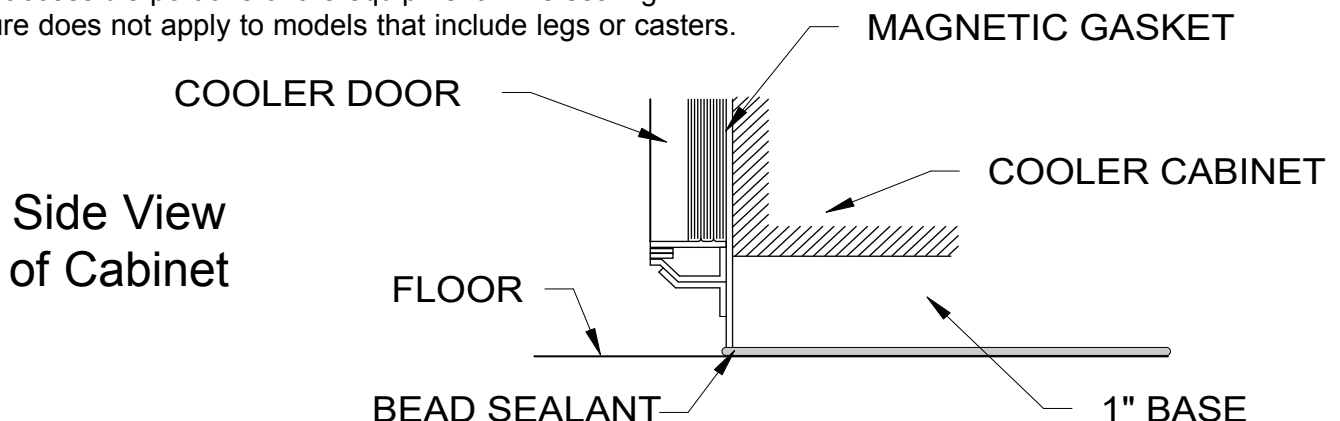

Installation

ATTENTION INSTALLER: WARNING!!

Failure to level this cooler WILL VOID THE FACTORY WARRANTY. Doors will not close properly causing damage to hinges, handles, and/or gaskets which will adversely affect the refrigeration systems.

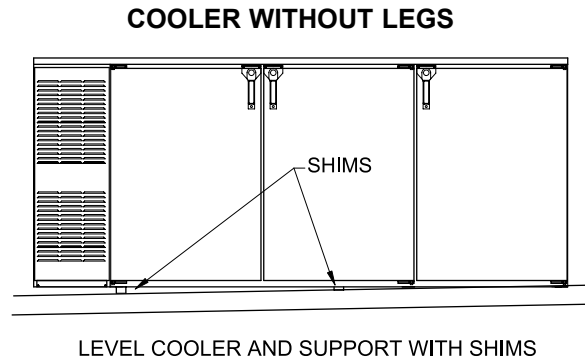
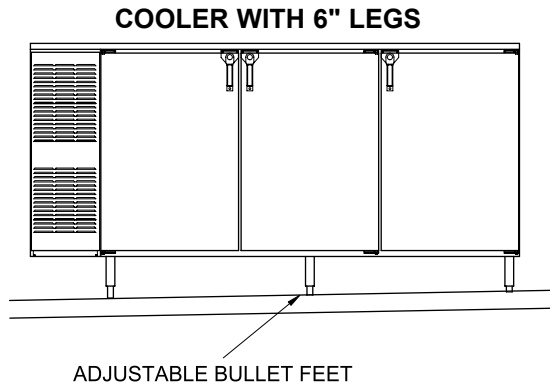

COOLER INSTALLATION CHECKLIST

- Is the unit evenly and solidly supported, either upon legs, or flat on the base; check for high spots?
- If the unit was designed for legs, are they attached?
- Is the unit level at the base, from end to end?
- Do the doors open and close freely, without touching any other part of the unit in travel?
- Are all open holes to the outside of the cabinet plugged or insulated?
- Are there obstructions of any kind to air flow into or out of the condensing unit?
- Is product tubing or are other lines installed in such a manner to not allow shelf access?

SPECIAL INSTRUCTIONS FOR BEER TOWER INSTALLATION

Before you begin:

1. Disassemble the tower into three parts, stiffener, skin, and top plate, by unscrewing the top two screws.
2. Mount the column stiffener with the provided four 1/4"-20x1-1/2" bolts.
3. Install insulation provided into the bottom of the column stiffener.
4. Place the column skin over the stiffener. Run the beer lines through the hole at the same time.
5. Install insulation provided into the top of the tower assembly.
6. Mount the column top plate to the column stiffener with the two #10-32x1/2" phillips flat head s/s machine screws provided.
7. Apply a bead of silicone sealant around the perimeter of the column. Use your finger to smooth out the bead.
8. Wash tapping device and faucet with detergent and water. Flush beer tapping device and faucet lines.

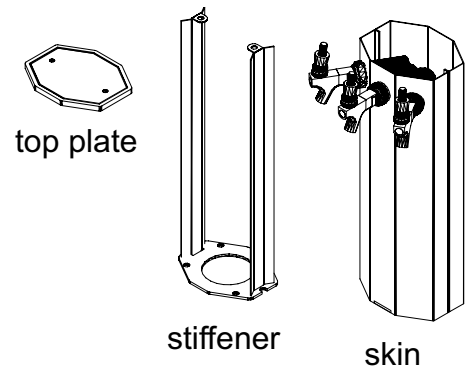

Cleaning

CLEANING INSTRUCTIONS

Cleaning is essential to sustaining the integrity of your equipment and preventing corrosion.

ESTIMATED CLEANING TIME: 5 to 10 minutes per unit daily, 45 minutes quarterly

FREQUENCY: Daily cleaning of exterior & door gaskets. Monthly cleaning of condenser filter. Quarterly cleaning of interior, including shelves.

PROCEDURE:

1. A non-chlorine based cleaner or mild detergent and warm water applied with a soft cloth or sponge to all contact surfaces.
2. Immediately rinse off cleaning agent(s), using clean warm water, clean soft cloth or sponge.
3. Dry with a soft clean cloth, removing standing water as soon as possible.
4. Condenser filter - remove compressor cover panel. Thermostat control probe wire will become disconnected and cause operation failure not covered by factory warranty (see page 2). Be careful while removing.

NOTES:

1. Never use hydrochloric acid, wire brushes, steel wool, scrapers, or chlorine based cleaners on stainless steel surfaces, since they will break down the passivity layer and allow corrosion to occur.
2. On stainless steel surfaces, you may use a soft bristle brush or Scotch-Brite® pad for more stubborn stains. Always scrub with the direction of the grain. Follow with a thorough cleaning as described above.
3. Deposits from food preparation must be properly removed. Even hard water deposits will rust stainless steel, if not removed.
4. Repeated cleaning may dry up black-vinyl-clad steel (exterior) surfaces of the cooler. Armor All® or similar product can bring back the shine. Apply the product to a cloth and then rub into the surface, rather than spraying it directly onto the black-vinyl-clad surface.
5. The cooler door gaskets are most often overlooked when cleaning. Failure to clean them regularly will lead to premature failure, since alcohol and moisture build-up breaks down the gasket material.



CS1FB Anti-Tip Bracket Installation

WARNING: The included anti-tip bracket **MUST** be installed when CS1FB is in use.

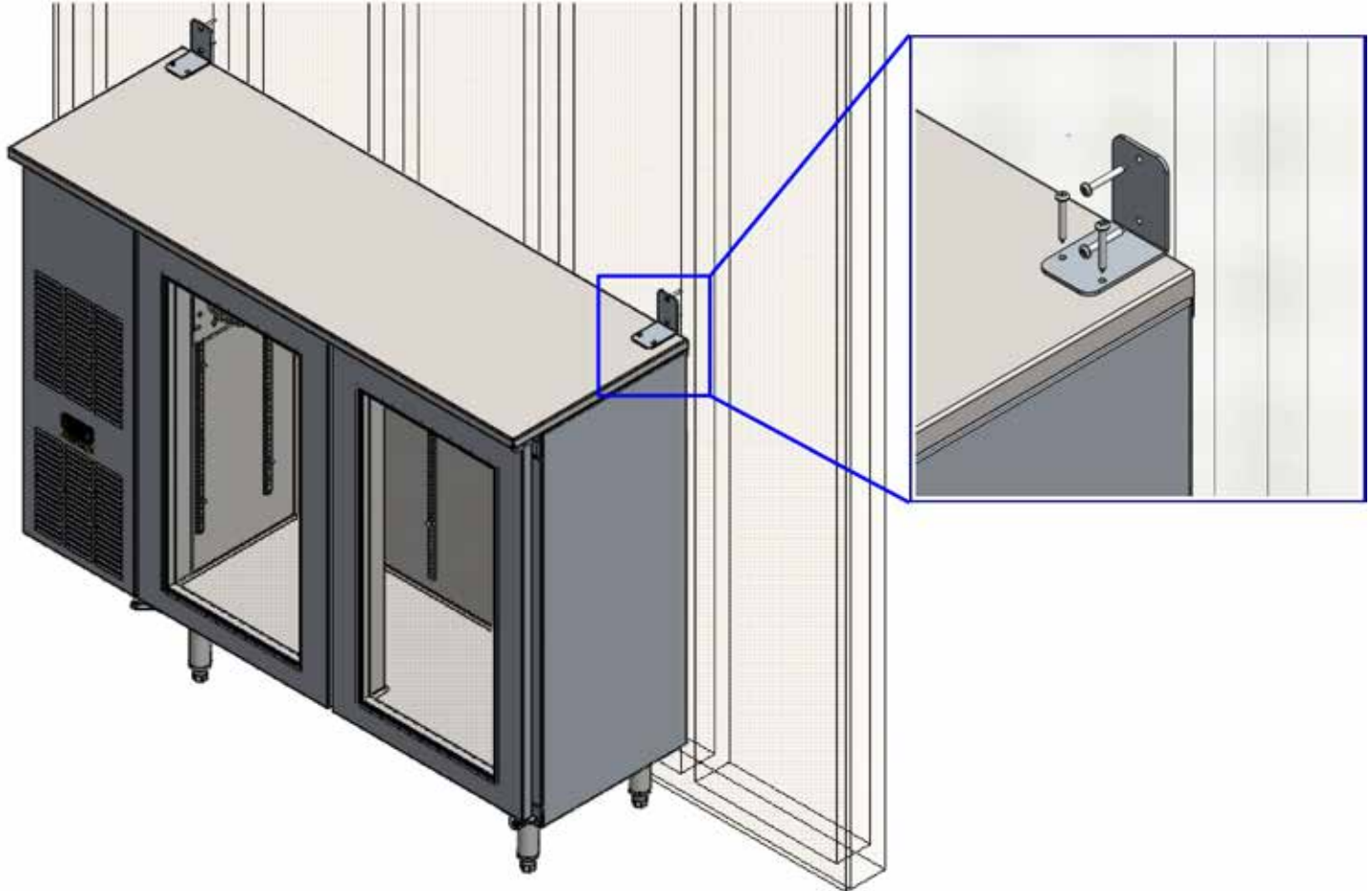

INSTALLATION INSTRUCTIONS WITH CASTERS

1. Install casters on cooler.
 2. Slide cooler into position. Locate wall studs and mark bracket holes.
 3. Slide cooler out and secure the bracket with 2 wood screws.
 4. Set the cooler in its final position.
- * To utilize the casters, do not secure the brackets to the top of the cooler.

INSTALLATION INSTRUCTIONS WITH LEGS

1. Install the cooler legs.
2. Set the cooler into position. Locate wall studs and mark bracket holes.
3. Mount each bracket to a wall stud with 2 wood screws.
4. Set the cooler in its final position.
5. Secure brackets to the top with provided stainless sheet metal screws.

Wiring Diagram C1F

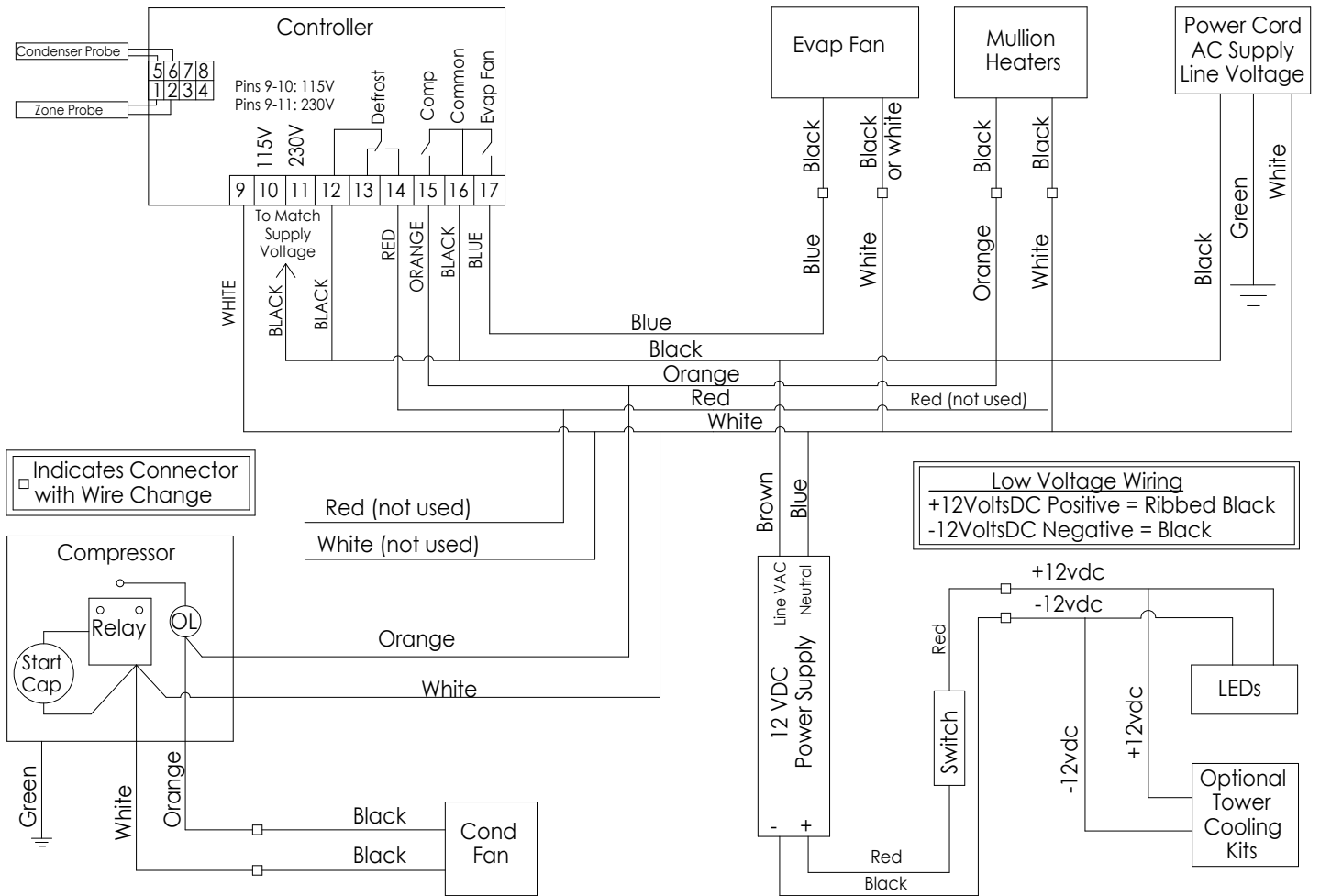

Wiring Diagram C2F

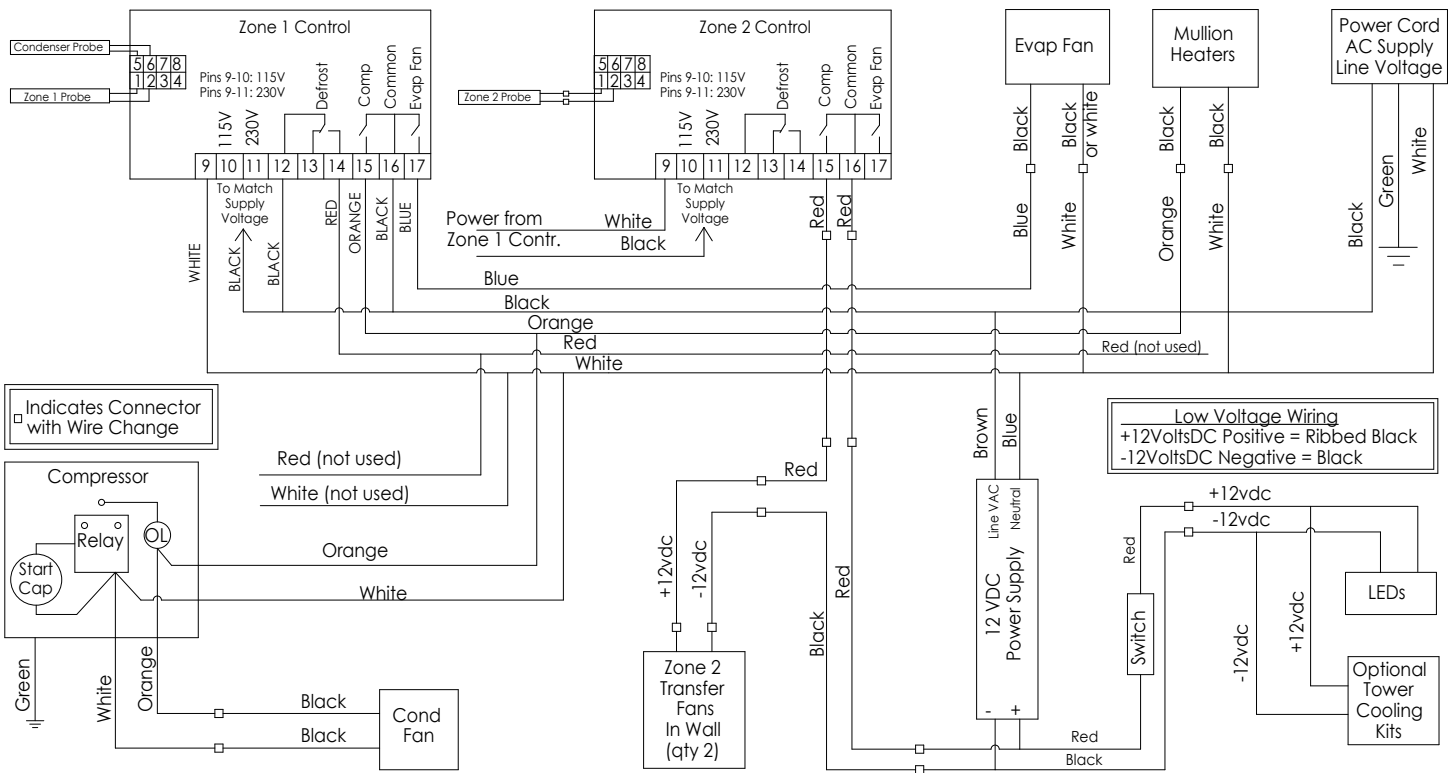

Wiring Diagram F1F

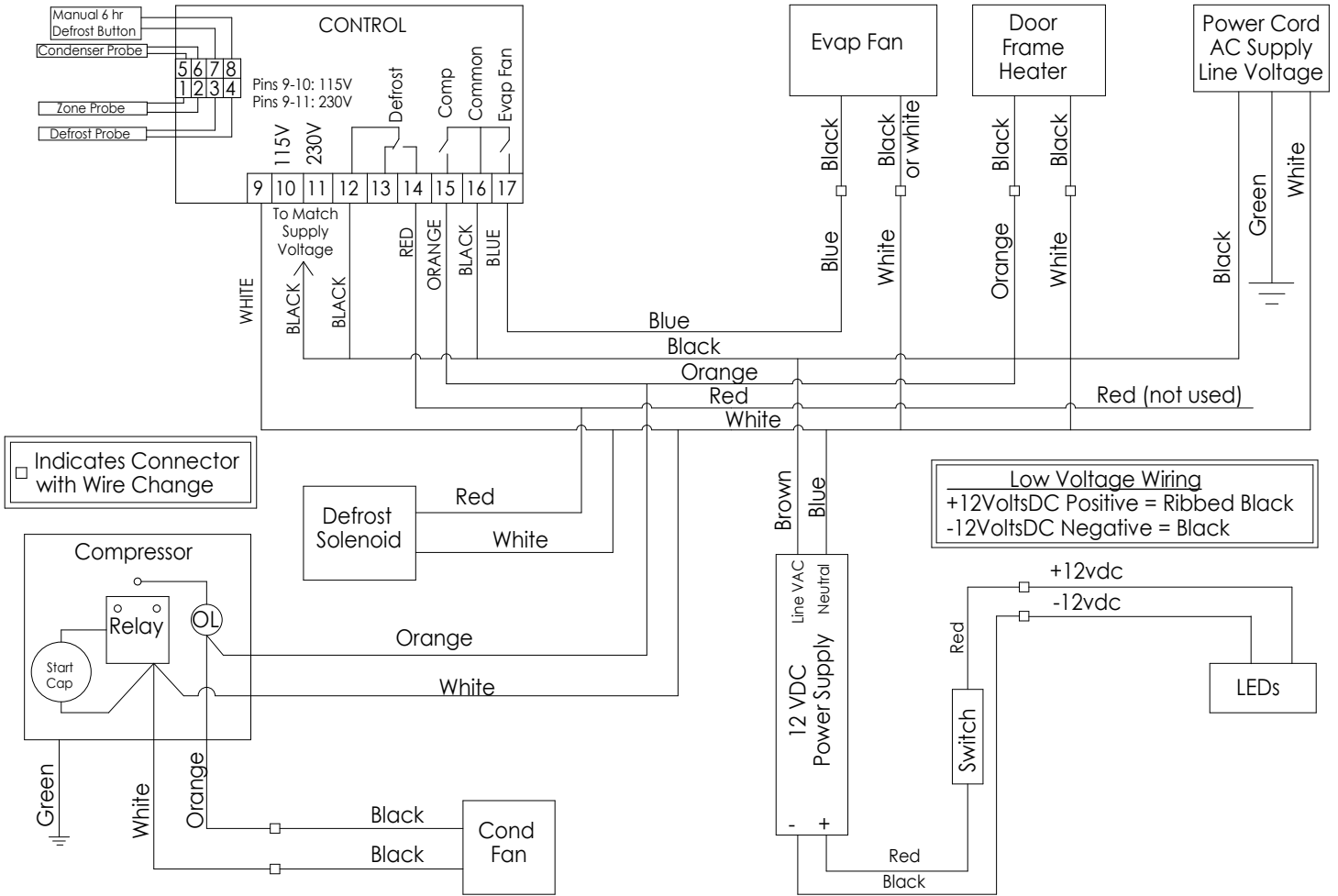

Terms and Conditions

Prices:

All prices are LIST. Applicable taxes will be added.

Quotations:

Unless otherwise stated, quotations are effective for 30 days only.

Acceptance:

All orders are subject to acceptance by Glastender, Inc.'s headquarters in Saginaw, Michigan. Possession of the Product Directory and Price List is not an offer to sell.

Shipments:

F.O.B. factory in Saginaw, Michigan. Freight terms are Third Party or Collect if shipped directly to you. Prepay and Add to Invoice freight terms are available upon request. The approximate shipping weights of all products are listed with the prices. Partial shipments will be made unless otherwise specified by the customer. Surface freight classifications are:

- GT-24/GT-30/GW24 Glasswashers - Class 175
- GT-18 Glasswashers - Class 175
- All Underbar Equipment - Class 175
- Bar Die Orders – Class 250
- Portable Bars - Class 175
- Remote refrigerators (i.e., no compressor) or dry storage back bar equipment - Class 175
- Self-contained refrigeration equipment - Class 150
- Ice Display Units (IDU and GDU) - Class 175
- Lighted Liquor Displays - Class 175
- Beer line chillers and beer towers (beverage dispensing equipment) - Class 175
- Bottle Disintegration System - Class 150
- Ice Cream Freezers - Class 125

All small items are evaluated to see the most cost effective means for shipment. Many small items ship via UPS or FedEx; however, when dimensional weight is excessive, LTL carriers are the most cost effective choice. Spare parts orders received before 1:00 PM EST can usually be shipped the same day.

The order department is happy to assist with routing or shipping questions.

Payment Terms:

Cash should be included with all orders unless credit terms have been arranged. To establish credit, banking and trade references are required. A convenient credit application is available upon request. Payment via credit card is not our normal means of receiving payment. Visa and MasterCard will be accepted, but must be charged at the time of shipment. In addition, a payment via credit card for orders totaling more than \$500 will incur a 3% convenience fee on the total transaction amount.

Delivery:

The majority of equipment is manufactured to order and typically ships within three to six weeks after complete order information is received by the factory. In-stock equipment typically ships within two to three days of the factory receiving complete order information.

Returns:

Items specified as "Manufactured to Order" are NOT returnable. A Return Authorization number must be issued by the factory in advance for any items that are returnable. The number MUST be noted on the outside of the returned package. Returns must be received within 90 days of the issue date. Shipping charges must be prepaid. A minimum 20% restocking charge will be applied to all authorized returns if received in new, unused condition in the original packaging.

The above conditions apply to spare part returns, except spare part returns must be received within 30 days of original shipment for electronic or electrical parts or within 90 days for all other parts.

Loss or Damage:

For customer routed shipments, Glastender, Inc. is not responsible for any loss, damage, or delay of merchandise during shipment. Such transit claims must be filed with the carrier. Merchandise must be examined on arrival. If shortages occur, Glastender,

Inc. must be notified in writing within five (5) days of delivery to honor any shortage claim. Glastender will assume responsibility for freight claims on Prepay and Add shipments but the customer must inspect freight and note any damage upon receipt. Failure to do so may result in losses at the customer's expense.

Custom Orders:

Custom orders must be paid in advance and are not subject to cancellation.

Laminates:

Some products include common, readily available plastic laminates of the customer's selection. There may be an additional charge if uncommon varieties are ordered.

Glastender Freight Program

Program Conditions

Glastender, Inc. equipment pricing includes standard freight costs under the following conditions:

- Equipment order is for a minimum of \$2,500, shipped to a single destination at the same time.
- Freight carrier is selected by Glastender, Inc. and may vary based on destination, transit times, performance history, customer service, or other factors.
- Shipping destination is within the continental United States and Canada. Non-continental or other international destinations are shipped to port of export.
- Combining equipment orders is allowed to reach the minimum order level if combined orders are shipped to the same destination at the same time.
- Equipment order terms of sale are FOB Saginaw MI / Freight Prepaid.
- Equipment returns are not covered.
- Parts orders do not qualify and will be charged shipping accordingly.

Customer Responsibilities

In addition to the program conditions listed above, the receiving customer must:

- Note all damage on the delivery receipt at the time of delivery.
- Open and inspect any items that look suspicious or raise concern, even if the carrier tells you it is not allowed.
- Refuse only the damaged items and keep the other items on the order.
- When in doubt, sign the delivery receipt as damaged.

The only way to hold the carrier liable is to sign the delivery as damaged.

Additional Fees

Additional carrier-related services and fees over and above standard freight costs are not covered. Such services and fees will be invoiced at the time of order or after the order has shipped.

Examples of additional fees include the following:

Split shipment	Cost difference between single shipment and split shipment
Lift gate	\$55 (Only available for items under 96" in total packaged length)
Inside delivery	\$100 per pallet/piece
Residential delivery	\$100
Limited access site	\$100
Expedited delivery	Difference from standard rate
Special delivery time	Carrier rate
Storage	Carrier rate
Re-delivery	Carrier rate
Re-consignment	Carrier rate
Other additional services not listed ...	Carrier rate

Questions

For questions regarding the Glastender Freight Program, please contact our sales department:

- 989.752.4275 or orders@glastender.com

Warranty Statement

(for products shipping June 1, 2025 and after)

APPLICABLE TO ALL PRODUCTS SOLD WITHIN THE UNITED STATES AND CANADA

Glastender, Inc. warrants all products to be free of defects in material and workmanship.

All Glasswashers and BDS models

One-year parts and labor warranty. Warranty is effective for one year from the date of installation or up to 18 months from date of factory shipment, whichever occurs sooner.

All Self-Contained Refrigeration Models

Two-year parts and labor warranty. Warranty is effective for two years from the date of installation or up to 30 months from date of factory shipment, whichever occurs sooner.

Authorization for labor must be obtained from Glastender within the warranty period and prior to the service being performed.

Labor warranty applies to the 50 states of the USA and Canada only.

Remote refrigeration models exclude the labor warranty for issues related to the field installation and test of the completed refrigeration system, provided by others.

Field replacement parts not covered under the original warranty include a 90-day part warranty from the date of installation.

EXTENDED PARTS & LABOR WARRANTY

Glastender's two-year parts and labor warranty on self-contained refrigeration models can be extended by one year with the purchase of an extended parts and labor warranty. Specify option number EWR3 (\$325 net price) when ordering.

FIVE YEAR COMPRESSOR PART WARRANTY

Glastender warrants the compressor for all self-contained refrigeration models for five years, running concurrently with the parts and labor warranty. After the parts and labor warranty expires, only the compressor is covered; no labor is covered.

A completed warranty claim form **MUST** accompany all returned defective parts or assemblies. Upon request, a defective part or assembly must be returned to Glastender, Inc., Saginaw, Michigan, with all transportation and delivery charges prepaid. Warranty repairs or replacements will be shipped FOB factory in Saginaw, Michigan. Reimbursement for applicable freight charges covers ground service only.

Glastender provides in-warranty repairs during a service company's regular working days and hours. There is no provision for payment of a premium rate during "overtime" hours. When warranty service is requested during other than normal working hours, the end user will be charged the premium portion of the overtime rate.

The warranty covers substantiated travel expenses for up to 2 hours / 100 miles round trip up to a maximum of \$225. Any additional costs due to installations that require extra work, time, or travel to gain access for service are the sole responsibility of the equipment purchaser. Any exceptions to these travel and access limitations must be pre-approved by a factory representative. The warranty does not cover door gaskets, chemical tubing, pump squeeze tubing, and/or any equipment subjected to accidents, freight damage, alterations from the original design, improper power and/or plumbing hookups, improper chemical use, general misuse, or lack of routine required maintenance as determined by Glastender, Inc. Installation, normal control adjustments, general maintenance, correcting an installation error, or service calls that reveal the unit is functioning normally will not be reimbursed under warranty.

Condenser coils on self-contained refrigeration products must be cleaned regularly. Failure to provide adequate air flow to a refrigeration unit will void the warranty.

Glastender shall not be liable for loss of use, revenue, or profit, or for any other indirect, incidental, special, or consequential damage including, but not limited to, product spoilage or loss.

This warranty is conditioned upon Glastender receiving notice of any defect subject to this warranty within sixty (60) days of its discovery by the end user or dealer. All products are warranted only for the initial place of installation. Removal of a product automatically terminates this warranty.

EXPORT WARRANTY - One year parts only.

EXCLUSION OF WARRANTIES

EXCEPT AS PROVIDED ABOVE, GLASTENDER MAKES NO WARRANTIES, EXPRESS OR IMPLIED, INCLUDING, BUT NOT LIMITED TO, ANY IMPLIED WARRANTY OF MERCHANTABILITY, FITNESS FOR A PARTICULAR PURPOSE OR NON-INFRINGEMENT.

LIMITATION OF REMEDIES AND DAMAGES

If Buyer makes a valid and timely claim as outlined above, Glastender's liability and Buyer's remedies under this agreement will be limited solely to labor charges authorized and/or replacement or credit, at Glastender's option, with respect to Products returned at Buyer's expense within thirty (30) days after warranty repair. GLASTENDER'S LIABILITY WILL IN NO EVENT BE GREATER IN AMOUNT THAN THE PURCHASE PRICE OF THE RETURNED PRODUCTS. GLASTENDER WILL NOT BE LIABLE UNDER ANY CIRCUMSTANCE FOR CONSEQUENTIAL OR INCIDENTAL DAMAGES, INCLUDING, BUT NOT LIMITED TO, LABOR COSTS EXCEPT AS COVERED UNDER OUR WARRANTY, LOST PROFITS OR THE LOSS OF PERISHABLE PRODUCTS RESULTING FROM THE USE OF OR INABILITY TO USE OUR PRODUCTS OR FROM OUR PRODUCTS' INCORPORATION INTO OR BECOMING A COMPONENT OF ANY OTHER PRODUCT. NEITHER PARTY WILL HAVE ANY NEGLIGENCE OR OTHER TORT LIABILITY TO THE OTHER, OR TO ANY THIRD PARTY, ARISING FROM ANY BREACH OF THIS AGREEMENT.

GOVERNING LAW - JURISDICTION

The terms and conditions of an order are to be governed and construed according to the laws of the State of Michigan, without regard to conflict of laws principles. Buyer hereby consents to the jurisdiction and venue of the courts located in Saginaw County, Michigan.

No representative, distributor, dealer, or any other person is authorized to modify this warranty. This warranty replaces all other written or verbal warranties.

NOTE: Glastender, Inc.'s policy of constant quality improvement means that prices, specifications, and policies are subject to change without notice. Questions regarding this warranty should be directed to Glastender's Warranty Administrator.

06-01-25

IMPORTANT!!

Attention Service Companies

Please review the important warranty information on this page. If you believe a service call should be covered by the factory, please call the factory for authorization between 8AM and 5PM EST, Monday through Friday.

Warranty Statement

(for products shipped before June 1, 2025)

APPLICABLE TO ALL PRODUCTS SOLD WITHIN THE UNITED STATES AND CANADA

Glastender, Inc. warrants all products to be free of defects in material and workmanship. One-year labor and parts warranty applies to all glasswashers, self-contained refrigeration models, and BDS model bottle disintegration units. In established areas, a start up is included with GT-24 and GT-30 model glasswashers. Warranty is effective for one year from the date of installation or up to 18 months from date of factory shipment, whichever occurs sooner. Glastender, Inc. will replace any part or assembly found defective under normal use and service.

For warranty labor claims beyond 12 months from the date of factory shipment, proof of date of installation or occupancy must be provided. Authorization for labor must be obtained from Glastender within the warranty period and prior to the service being performed.

Labor warranty applies to the 50 states of the USA and Canada only.

Remote refrigeration models exclude the labor warranty for the condensing unit and issues related to the field installation and test of the completed refrigeration system, provided by others.

Field replacement parts not covered under the original warranty include a 90-day part warranty from the date of installation.

FOUR YEAR ADDITIONAL COMPRESSOR WARRANTY

Glastender will warrant to the original user the compressor for all self-contained refrigeration models for an additional four years following the regular one-year warranty period. This plan applies to the compressor only.

A completed warranty claim form **MUST** accompany all returned defective parts or assemblies. Upon request, a defective part or assembly must be returned to Glastender, Inc., Saginaw, Michigan, with all transportation and delivery charges prepaid. Warranty repairs or replacements will be shipped FOB factory in Saginaw, Michigan. Reimbursement for applicable freight charges covers ground service only.

Glastender provides in-warranty repairs during a service company's regular working days and hours. There is no provision for payment of a premium rate during "overtime" hours. When warranty service is requested during other than normal working hours, the end user will be charged the premium portion of the overtime rate.

The warranty covers substantiated travel expenses for up to 2 hours / 100 miles round trip up to a maximum of \$225. Any additional costs due to installations that require extra work, time, or travel to gain access for service are the sole responsibility of the equipment purchaser. Any exceptions to these travel and access limitations must be pre-approved by a factory representative.

The warranty does not cover door gaskets, chemical tubing, pump squeeze tubing, and/or any equipment subjected to accidents, freight damage, alterations from the original design, improper power and/or plumbing hookups, improper chemical use, general misuse, or lack of routine required maintenance as determined by Glastender, Inc. Installation, normal control adjustments, general maintenance, correcting an installation error, or service calls that reveal the unit is functioning normally will not be reimbursed under warranty.

Condenser coils on self-contained refrigeration products must be cleaned regularly. Failure to provide adequate air flow to a refrigeration unit will void the warranty.

Glastender shall not be liable for loss of use, revenue, or profit, or for any other indirect, incidental, special, or consequential damage including, but not limited to, product spoilage or loss.

Glastender, Inc. • 5400 North Michigan Road • Saginaw, MI • 48604-9780
800.748.0423 • 989.752.4275 • Fax 989.752.4444 • <https://glastender.com>

This warranty is conditioned upon Glastender receiving notice of any defect subject to this warranty within sixty (60) days of its discovery by the end user or dealer. All products are warranted only for the initial place of installation. Removal of a product automatically terminates this warranty.

SECOND YEAR EXTENDED PARTS & LABOR WARRANTY

Glastender's one-year parts and labor warranty on self-contained refrigeration units can be extended to two years with the purchase of a two year parts and labor warranty. Specify part number EWR2 (\$250 net price) when ordering.

EXPORT WARRANTY - One year parts only.

EXCLUSION OF WARRANTIES

EXCEPT AS PROVIDED ABOVE, GLASTENDER MAKES NO WARRANTIES, EXPRESS OR IMPLIED, INCLUDING, BUT NOT LIMITED TO, ANY IMPLIED WARRANTY OF MERCHANTABILITY, FITNESS FOR A PARTICULAR PURPOSE OR NON-INFRINGEMENT.

LIMITATION OF REMEDIES AND DAMAGES

If Buyer makes a valid and timely claim as outlined above, Glastender's liability and Buyer's remedies under this agreement will be limited solely to labor charges authorized and/or replacement or credit, at Glastender's option, with respect to Products returned at Buyer's expense within thirty (30) days after warranty repair. GLASTENDER'S LIABILITY WILL IN NO EVENT BE GREATER IN AMOUNT THAN THE PURCHASE PRICE OF THE RETURNED PRODUCTS. GLASTENDER WILL NOT BE LIABLE UNDER ANY CIRCUMSTANCE FOR CONSEQUENTIAL OR INCIDENTAL DAMAGES, INCLUDING, BUT NOT LIMITED TO, LABOR COSTS EXCEPT AS COVERED UNDER OUR WARRANTY, LOST PROFITS OR THE LOSS OF PERISHABLE PRODUCTS RESULTING FROM THE USE OF OR INABILITY TO USE OUR PRODUCTS OR FROM OUR PRODUCTS' INCORPORATION INTO OR BECOMING A COMPONENT OF ANY OTHER PRODUCT. NEITHER PARTY WILL HAVE ANY NEGLIGENCE OR OTHER TORT LIABILITY TO THE OTHER, OR TO ANY THIRD PARTY, ARISING FROM ANY BREACH OF THIS AGREEMENT.

GOVERNING LAW - JURISDICTION

The terms and conditions of an order are to be governed and construed according to the laws of the State of Michigan, without regard to conflict of laws principles. Buyer hereby consents to the jurisdiction and venue of the courts located in Saginaw County, Michigan.

No representative, distributor, dealer, or any other person is authorized to modify this warranty. This warranty replaces all other written or verbal warranties.

NOTE: Glastender, Inc.'s policy of constant quality improvement means that prices, specifications, and policies are subject to change without notice. Questions regarding this warranty should be directed to Glastender's Warranty Administrator.

02-16-23

IMPORTANT!!

Attention Service Companies

Please review the important warranty information on this page. If you believe a service call should be covered by the factory, please call the factory for authorization between 8AM and 5PM EST, Monday through Friday.