



# VEGETABLE PREPARATION MACHINE CA-41

High production vegetable preparation machine with an hourly output of up to 1300 lb.



DYNAMIC PREPARATION  
COMMERCIAL VEGETABLE PREPARATION MACHINES



## INCLUDES

- ✓ 1 speed motor block.
- ✓ Large capacity hopper.
- ✓ Core drill (optional use).
- ✓ Universal grid cleaner QC-U.

## OPTIONAL

- Tube head.
- High production semi-automatic hopper.
- Support-trolley.
- Discs and grids.
- Grid cleaning kit.

## ACCESSORIES

- FCC curved slicing discs
- FCO rippled slicing discs
- FFC chipping grids
- FMC dicing grids
- FCE julienne discs
- Long vegetable attachment
- Disc and grid packs - Heavy Duty
- Disc and grid holder
- Stand-trolley
- Automatic hopper
- Quick Cleaner: grid cleaners
- FC-D slicing discs
- SH shredding & grating discs
- Déli-cut cutting kit - Heavy Duty
- Universal grid cleaner QC-U

## SALES DESCRIPTION

Single-speed motor block + large production attachment.

### A perfect cut

- ✓ High precision adjustments to obtain a uniform and excellent-quality cut.
- ✓ It can be fitted with a wide range of discs and grids of the highest cutting quality. By combining these accessories, it is possible to obtain more than 70 different types of cuts and grating grades.
- ✓ Head with blade on one side that distributes products inside the mouth and cuts and distributes whole products such as cabbage.
- ✓ Head equipped with high ejector: enables a higher quantity of product to be processed.

### Built to last

- ✓ Made from stainless steel and food-grade materials of the highest quality: stainless steel motor block and food-grade aluminium head.
- ✓ High power asynchronous motor.

### Maximum comfort for the user

- ✓ Ergonomic design for maximum user comfort.
- ✓ Lateral product output: requires less space on the worktop and guides the product, avoiding splashes.
- ✓ The electronic command panel is very intuitive.

### Maintenance, safety, hygiene

- ✓ Lever and lid easily removable for cleaning purposes.
- ✓ Combination of safety systems: head, cover, power switch.
- ✓ Appliance certified by NSF International (regulations on hygiene, cleaning and materials suitable for contact with foods).
- ✓ 100% tested.

## SPECIFICATIONS

**Hourly production (pieces):** 400 lb - 1300 lb

**Inlet opening:** 44.4 in<sup>2</sup>

**Disc diameter:** 8"

**Motor speed:** 365 rpm

**Total loading:** 1.5 Hp

**Noise level (1m.):** <70 dB(A)

**Background noise:** 32 dB(A)

### External dimensions (W x D x H)

Width: 15.4"

Depth: 15.6"

Height: 25.7"

Crated dimensions

17.3 x 16.9 x 27.6"

Volume Packed: 0.13 m<sup>3</sup>

Gross weight: 62.8 lbs.

## AVAILABLE MODELS

1050721 Vegetable preparation machine CA-41 230-400/50/3N

1050720 Vegetable preparation machine CA-41 120/60/1

1050731 Vegetable preparation machine CA-41 230/50/1 UK

\* Ask for special versions availability





# VEGETABLE PREPARATION MACHINE CA-41

High production vegetable preparation machine with an hourly output of up to 1300 lb.



DYNAMIC PREPARATION  
COMMERCIAL VEGETABLE PREPARATION MACHINES

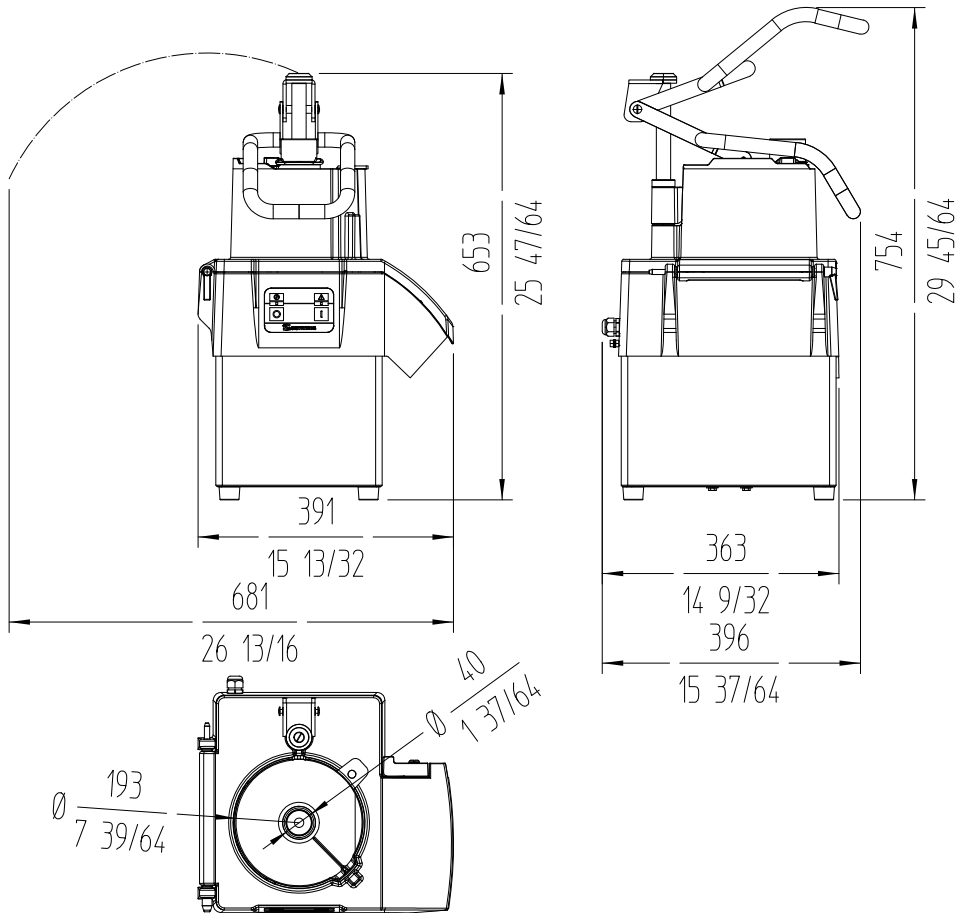

**sammic** | www.sammic.us  
Food Service Equipment Manufacturer

usa@sammic.com  
1225 Hartrey Avenue  
60202-1056 Evanston, IL

phone +1 (224) 307-2232  
toll free +1 844 275 3848



Project	Date
Item	Qty
Approved	

product sheet  
updated 12/02/24