



VEGETABLE PREPARATION MACHINE CA-31

Vegetable preparation machine. Production up to 1000 lb.



OPTIONAL

- Tube head for long products.
- Support-trolley.
- Discs and grids.
- Grid cleaning kit.

ACCESSORIES

- FCC curved slicing discs
- FCO rippled slicing discs
- FFC chipping grids
- FMC dicing grids
- FCE julienne discs
- Long vegetable attachment
- Disc and grid packs - Heavy Duty
- Disc and grid holder
- Stand-trolley
- Quick Cleaner: grid cleaners
- FC-D slicing discs
- SH shredding & grating discs
- Déli-cut cutting kit - Heavy Duty
- Universal grid cleaner QC-U

SPECIFICATIONS

Hourly production (pieces): 300 lb - 1000 lb

Inlet opening: 21 in²

Disc diameter: 8"

Motor speed: 365 rpm

Total loading: 1.5 Hp

Noise level (1m.): <70 dB(A)

Background noise: 32 dB(A)

External dimensions (W x D x H)

Width: 15.4"

Depth: 16"

Height: 21.4"

Net weight: 46 lb

Crated dimensions

17.1 x 16.9 x 23.6 "

Volume Packed: 0.11 m³

Gross weight: 56.2 lbs.

AVAILABLE MODELS

1050702 Vegetable preparation machine CA-31 120/60/1

1050712 Vegetable preparation machine CA-31 230/50/1 UK

1050703 Vegetable preparation machine CA-31 CP 120/60/1

* Ask for special versions availability

SALES DESCRIPTION

Single-speed motor block + regular hopper.

A perfect cut

- ✓ High precision adjustments to obtain a uniform and excellent-quality cut.
- ✓ It can be fitted with a wide range of discs and grids of the highest cutting quality. Combining these accessories together to obtain more than 70 different types of cuts and grating grades.

Built to last

- ✓ Made from stainless steel and food-grade materials of the highest quality: stainless steel motor block and food-grade aluminium head.
- ✓ High power asynchronous motor.

Maximum comfort for the user

- ✓ Ergonomic design: product sliced in one single movement.
- ✓ Lateral product output: requires less space on the worktop and guides the product, avoiding splashes.
- ✓ The electronic command panel is very intuitive.

Maintenance, safety, hygiene

- ✓ Lever and lid easily removable for cleaning purposes.
- ✓ Combination of safety systems: head, cover, power switch.
- ✓ Appliance certified by NSF International (regulations on hygiene, cleaning and materials suitable for contact with foods).
- ✓ 100% tested.

INCLUDES

- ✓ Single-speed motor block.
- ✓ Regular hopper.
- ✓ Universal grid cleaner QC-U.



DYNAMIC PREPARATION
COMMERCIAL VEGETABLE PREPARATION MACHINES

product sheet
updated 11/20/24



VEGETABLE PREPARATION MACHINE CA-31

Vegetable preparation machine. Production up to 1000 lb.



DYNAMIC PREPARATION
COMMERCIAL VEGETABLE PREPARATION MACHINES

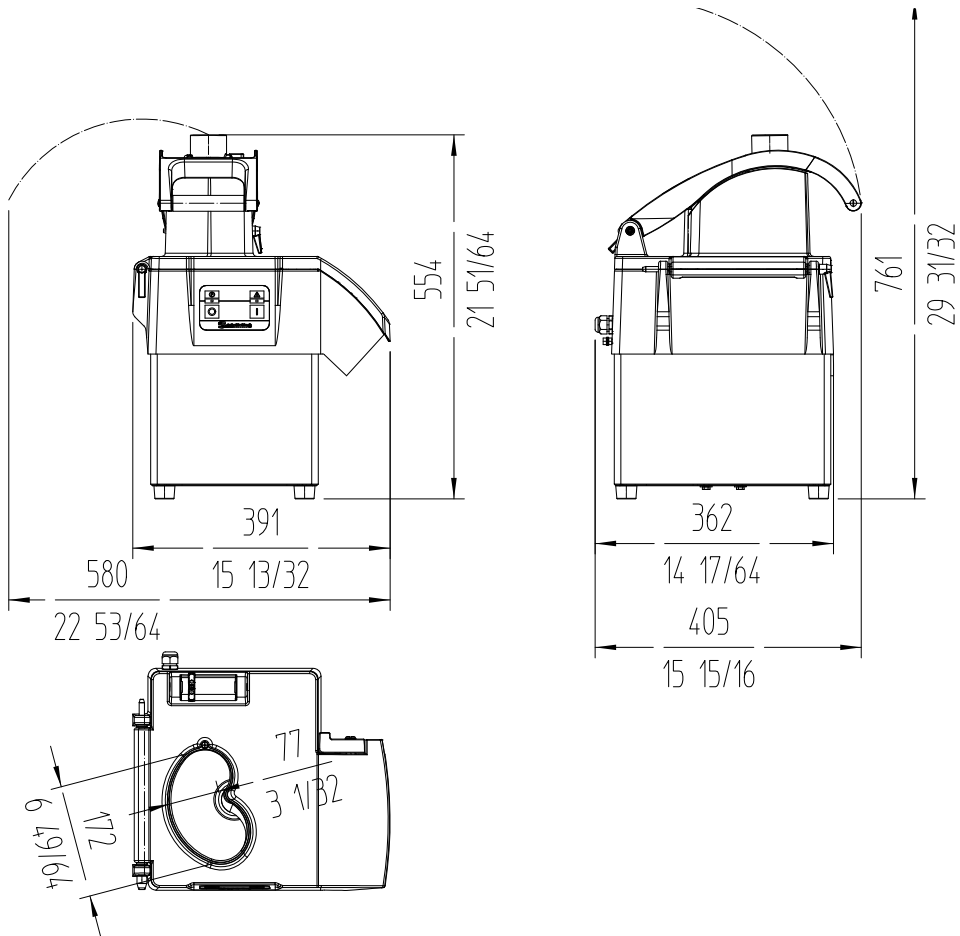

sammic | www.sammic.us
Food Service Equipment Manufacturer

usa@sammic.com
1225 Hartrey Avenue
60202-1056 Evanston, IL

phone +1 (224) 307-2232
toll free +1 844 275 3848



Project	Date
Item	Qty
Approved	

product sheet
updated 11/20/24