



# FOOD-PROCESSOR K-41

Bowl capacity: 4.4 l. 1 speed.



## SALES DESCRIPTION

Compact ACTIVE line. 1-speed motor block + 4.4 l cutter bowl with lateral stirrers and toothed blades.

### Efficiency and performance.

- ✓ 4.4 l-bowl equipped with lateral stirrer and high shaft for larger production capacity.
- ✓ Transparent lid equipped with hole to add ingredients in use.
- ✓ Lid complete with gasket to avoid product overflowing.
- ✓ Homogeneous and fine mixing result thanks to the lateral stirrers and invert-blade technology.
- ✓ The lateral stirrers avoid product overheating.
- ✓ Very uniform finish due to the movement generated the special position of the cutting edges.
- ✓ Depending on usage, optional smooth or perforated blades available.
- ✓ Optional vegetable slicer attachment available.

### Built to last

- ✓ Sturdy construction in food-grade best quality materials.
- ✓ High power asynchronous motor.

### Maximum comfort for the user

- ✓ Cutter bowl equipped with ergonomic handle.
- ✓ The electronic command panel is very intuitive.
- ✓ Recessed cord relief allowing flush against wall operation

### Maintenance, safety, hygiene

- ✓ Safety microswitches in the position of the bowl and the lid.
- ✓ Complete error warning system.
- ✓ Appliance certified by NSF International (regulations on hygiene, cleaning and materials suitable for contact with foods).
- ✓ 100% tested.

## INCLUDES

- ✓ 1-speed motor block. blades.
- ✓ Cutter bowl with toothed blades. ✓ Built-in lateral stirrers.

## OPTIONAL

- Hub with smooth blades.
- Vegetable slicer attachment.
- Hub with perforated blades.

## ACCESSORIES

- Cutter bowl
- Vegetable preparation attachment for K-41 / KE-4V
- Hubs with blades

## SPECIFICATIONS

Plug: USA (NEMA 5-15P / 2P+G)  
 Bowl capacity: 4.65 qt  
 Max. product capacity: 5.5 lb  
 Maximum capacity (liquid): 2.5 qt  
 Bowl dimensions: Ø7.6" x 6.34"  
 Total loading: 1.5 Hp (8,2 A)  
 Speed, min-max: 1800 rpm

### External dimensions (W x D x H)

- ✓ Width: 9.9"
- ✓ Depth: 12.2"
- ✓ Height: 17.1"

Net weight: 31.3 lb

Crated dimensions  
 11.2 x 15.2 x 27.4 "  
 Volume Packed: 0.08 m³  
 Gross weight: 40.6 lbs.

## AVAILABLE MODELS

1050992 Cutter K-41 120/60/1

\* Ask for special versions availability

DYNAMIC PREPARATION  
CUTTER-MIXERS & EMULSIFIERS



product sheet  
updated 11/28/24



# FOOD-PROCESSOR K-41

Bowl capacity: 4.4 l. 1 speed.



DYNAMIC PREPARATION  
CUTTER-MIXERS & EMULSIFIERS

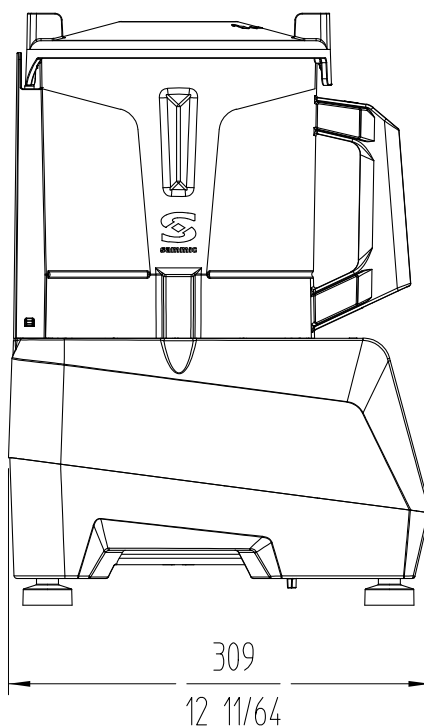
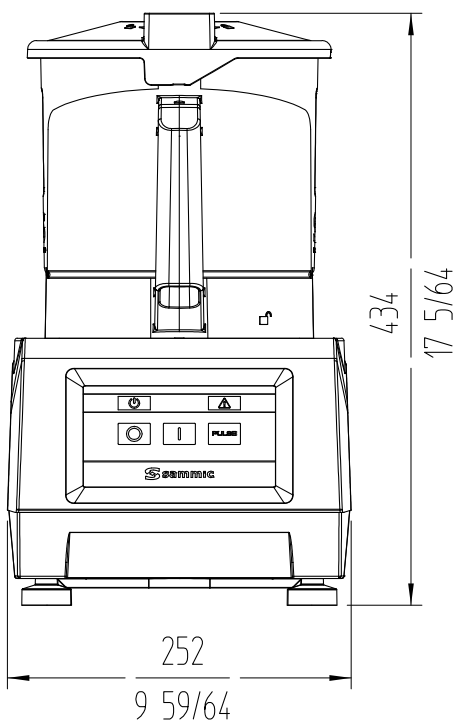

**sammic** | [www.sammic.us](http://www.sammic.us)  
Food Service Equipment Manufacturer

[usa@sammic.com](mailto:usa@sammic.com)  
1225 Hartrey Avenue  
60202-1056 Evanston, IL

phone +1 (224) 307-2232  
toll free +1 844 275 3848



Project	Date
Item	Qty
Approved	

product sheet  
updated 11/28/24