



COMBI CK-24V

2-in-1. Compact vegetable slicer + cutter. Adjustable speed with “brushless” technology.



SALES DESCRIPTION

Compact ULTRA line. Variable speed motor block + vegetable slicer attachment + 4.4 l cutter bowl. “Brushless” technology.

Equipped with “brushless” technology: powerful and efficient motors

- ✓ Maximum efficiency: maintain the torque throughout the speed range.
- ✓ Exclusive “Force control system”: guarantee of a uniform and high quality result.
- ✓ Lightweight and compact design: they weigh less, they occupy less space.
- ✓ Improved air/water-tightness since no ventilation is required.
- ✓ They generate less noise: improved workplace environment.

Vegetable slicer function: a perfect cut

- ✓ High precision settings and comprehensive cutter and disc design aimed at obtaining a perfect cut.
- ✓ Gravity Slide System allow to reconstruct the sliced product for storing or presentation purpose.
- ✓ Ejection disc included for the products that require its use.
- ✓ It can be fitted with a wide range of discs and grids of the highest cutting quality.

Combining these accessories together to obtain more than 35 different types of cuts and grating grades.

- ✓ Exclusive “Force control system” to optimise and standardise the cutting of each product: acoustic warning when the motor exceeds the pre-established force.

Cutter function: efficiency and performance

- ✓ Possibility of programming by time and pulse button.
- ✓ 4.4 l-bowl equipped with lateral stirrer and high shaft to obtain a bigger production.

- ✓ Transparent lid equipped with hole to add ingredients in use.
- ✓ Lid complete with gasket to avoid product overflowing.
- ✓ Homogeneous and fine mixing result thanks to the lateral stirrers and invert-blade technology.
- ✓ The lateral stirrers avoid product overheating.
- ✓ Very uniform finish due to the movement generated the special position of the cutting edges.
- ✓ Depending on the purpose, the possibility of using optional smooth or perforated blades.
- ✓ Built-in parametrisable programs to obtain the desired texture in seconds and in a standardized way: dense texture, fine texture, pulses (PrecisePulse function).
- ✓ Option to customize programs for recipe standardization.

Built to last

- ✓ Sturdy construction in food-grade best quality materials.

Maximum comfort for the user

- ✓ Ergonomic design: product sliced in one single movement.
- ✓ Cutter bowl equipped with ergonomic handle.
- ✓ Lateral product output: requires less space on the worktop and guides the product, avoiding splashes.
- ✓ Adjustable product ejection direction to adapt to the workflow in the preparation area.
- ✓ Advanced control panel that is very intuitive to use and offers all the information at a glance.
- ✓ Recessed cored relief allows for any position in the kitchen, side walls, back wall, light and compact, this machine can fit.
- ✓ Control panel equipped with timer to standardise processes.

Maintenance, safety, hygiene

- ✓ Lever, lid and bowl are easily removable for cleaning purposes.
- ✓ Stainless steel, dishwasher-safe discs. The removable blades allow for an even more thorough and efficient cleaning.
- ✓ Combination of safety systems: head, cover, bowl, power switch.
- ✓ Complete error warning system.
- ✓ Appliance certified by NSF International (regulations on hygiene, cleaning and materials suitable for contact with foods).
- ✓ 100% tested.

INCLUDES

- ✓ Variable speed motor block.
- ✓ Vegetable slicer attachment.
- ✓ Cutter bowl with toothed blades.
- ✓ Gravity product expulsion ramp.
- ✓ Ejection disc.
- ✓ CK-24V 2D includes 2 discs: FCS-4 (4 mm slicing disc) and SHS-2 (2 mm shredding disc).

OPTIONAL

- Hub with smooth blades.
- Hub with perforated blades.

ACCESSORIES

- FCS slicing discs
- FCOS rippled slicing disc
- FMS dicing grid
- FFS chipping grid
- FCES julienne discs
- SHS shredding & grating discs

SPECIFICATIONS

Total loading: 2 Hp (10 A)

As vegetable preparation machine



DYNAMIC PREPARATION
FOOD PROCESSOR / VEG PREP COMBI MACHINES

product sheet
updated 11/12/24



COMBI CK-24V

2-in-1. Compact vegetable slicer + cutter. Adjustable speed with "brushless" technology.



Hourly production: 110 lb - 770 lb
Inlet opening: 13.8 in²
Disc diameter: 7.1"
Speed as veg. slicer: 300 - 1000 rpm
External dimensions (W x D x H): 14.9" x 12.2" x 21"
Net weight (Veg.Prep.): 28.4 lb

Crated dimensions
15.0 x 22.2 x 18.9 "
Volume Packed: 0.1 m³
Gross weight: 40.8 lbs.

AVAILABLE MODELS

1050924 Combi vegetable prep.-cutter CK-24V 230/50-60/1 UK

1050930 Combi vegetable prep.-cutter CK-24V 2D 120/50-60/1 · 2 discs included

* Ask for special versions availability

As cutter

Bowl capacity: 4.65 qt
Speeds as cutter (positions): 300 - 3000 rpm
External dimensions (W x D x H): 9.9" x 12.2" x 17.1"
Net weight (Cutter): 26.2 lb
Noise level (1m.): <70 dB(A)
Background noise: 32 dB(A)

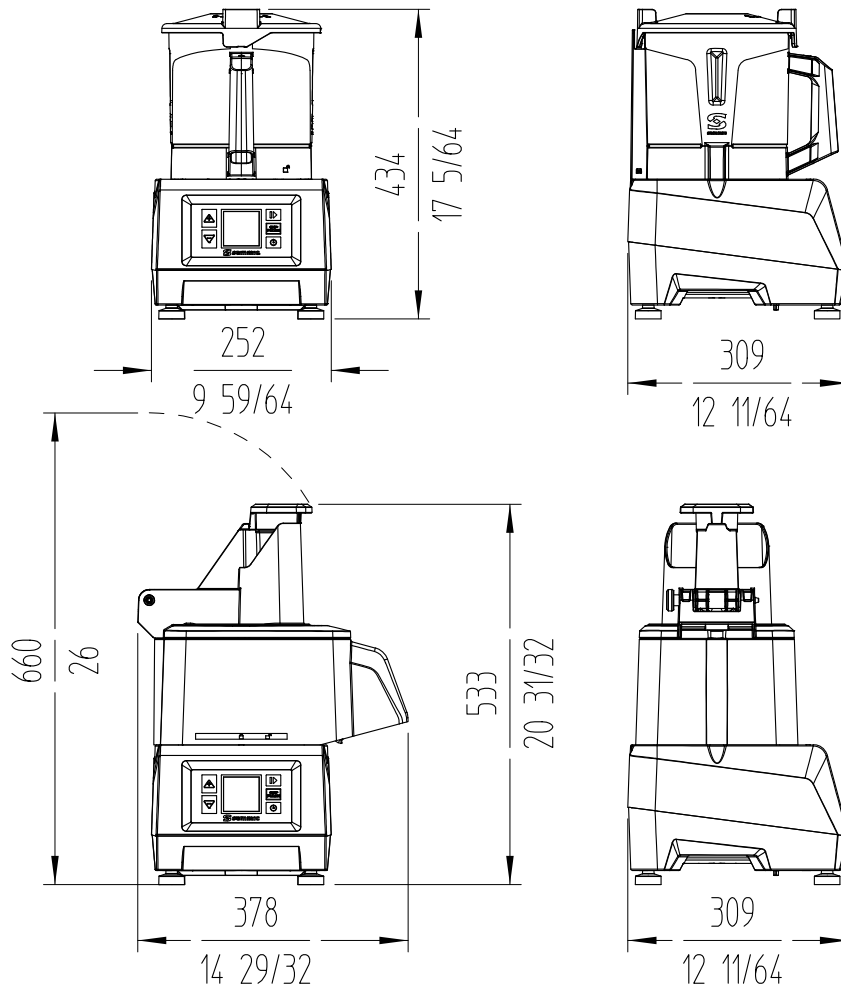

DYNAMIC PREPARATION
FOOD PROCESSOR / VEG PREP COMBI MACHINES

sammic | www.sammic.us
Food Service Equipment Manufacturer

usa@sammic.com
1225 Hartrey Avenue
60202-1056 Evanston, IL

phone +1 (224) 307-2232
toll free +1 844 275 3848



| | |
|----------|------|
| Project | Date |
| Item | Qty |
| Approved | |

product sheet
updated 11/12/24