



# FOOD-PROCESSOR - EMULSIFIER KE-5V

Bowl capacity: 5.5 l. Adjustable speed with “brushless” technology.



DYNAMIC PREPARATION  
CUTTER-MIXERS & EMULSIFIERS

## Maximum comfort for the user

- ✓ Advanced control panel that is very intuitive to use and offers all the information at a glance.

## Maintenance, safety, hygiene

- ✓ Safety microswitches on the hopper and lid position.
- ✓ Appliance certified by NSF International (regulations on hygiene, cleaning and materials suitable for contact with foods).
- ✓ 100% tested.

## INCLUDES

- ✓ Set of serrated blades.
- ✓ “Cut&mix” scraper.

## OPTIONAL

- Smooth blades.
- Perforated blades.

## ACCESSORIES

- Blades for CK / K / KE
- “Cut&mix” scrapers CK / K / KE

## SPECIFICATIONS

Bowl capacity: 5.8 qt  
 Bowl dimensions: Ø9.4” x 5.9”  
 Total loading: 3 Hp  
 Speed, min-max: 300 rpm / 3000 rpm

### External dimensions (W x D x H)

- ✓ Width: 11.3”
  - ✓ Depth: 15.2”
  - ✓ Height: 19.2”
- Net weight: 39.7 lb

Crated dimensions  
 17.3 x 14.0 x 22.4 “  
 Volume Packed: 0.09 m³  
 Gross weight: 51.8 lbs.

## AVAILABLE MODELS

1050834	Cutter-emulsifier KE-5V 230/50-60/1
1050836	Cutter-emulsifier KE-5V 120/50-60/1
1050842	Cutter-emulsifier KE-5V 230/50-60/1 K

\* Ask for special versions availability

## SALES DESCRIPTION

- ✓ ULTRA Heavy Duty line. Adjustable speed motor block + 5.5 l cutter bowl with toothed blades and “cut&mix” scraper.
- ✓ To cut, grind, texturize, mix and knead any food in seconds.
- ✓ Ideal for emulsions and texturizations.
- ✓ Brushless technology: maximum efficiency.

### Equipped with “brushless” technology: powerful and efficient motors.

- ✓ Maximum efficiency: maintain the torque throughout the speed range.
- ✓ Exclusive “force control system”: guarantee of a uniform and high quality result.
- ✓ Lightweight and compact design: they weigh less, they occupy less space.
- ✓ Improved air/water-tightness since no ventilation is required.
- ✓ They generate less noise: improved workplace environment.

### Efficiency and performance

- ✓ Possibility of programming by time and pulse button.
- ✓ Reverse function, ideal for mixing products instead of cutting.
- ✓ 5.5 litre stainless steel hopper.
- ✓ Transparent lid with built-in “cut&mix” mixer.
- ✓ Depending on the purpose, the possibility of using optional smooth or perforated blades.

### Built to last

- ✓ Robust construction of stainless steel and food-grade materials of the highest quality: stainless steel motor block with aluminium lid. Stainless steel hopper with highly-resistant transparent lid.



product sheet  
updated 11/28/24



# FOOD-PROCESSOR - EMULSIFIER KE-5V

Bowl capacity: 5.5 l. Adjustable speed with "brushless" technology.



DYNAMIC PREPARATION  
CUTTER-MIXERS & EMULSIFIERS

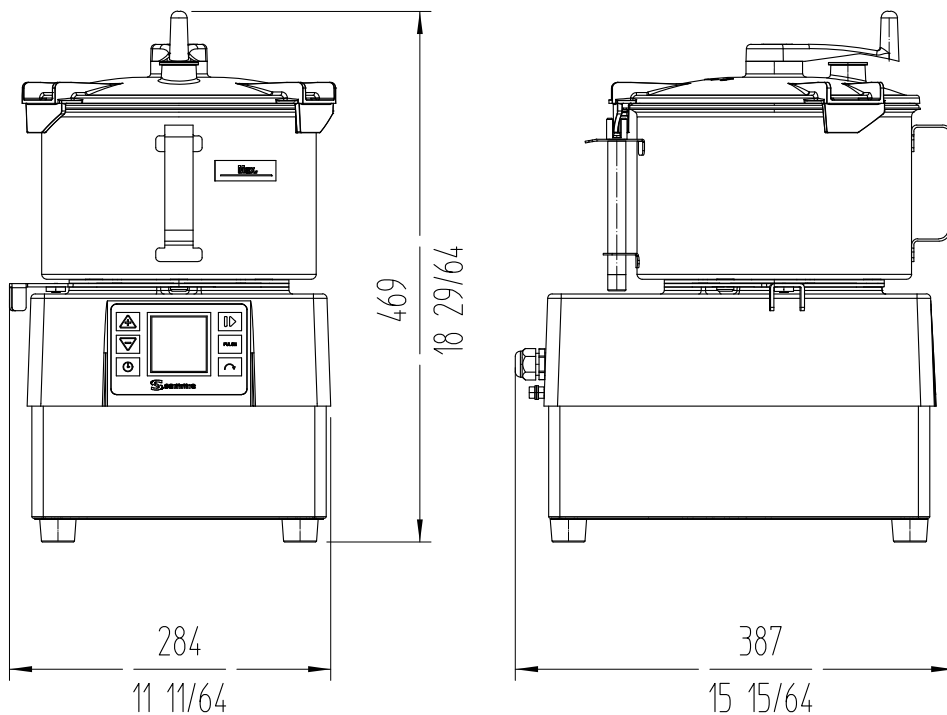

**sammic** | [www.sammic.us](http://www.sammic.us)  
Food Service Equipment Manufacturer

[usa@sammic.com](mailto:usa@sammic.com)  
1225 Hartrey Avenue  
60202-1056 Evanston, IL

phone +1 (224) 307-2232  
toll free +1 844 275 3848



Project	Date
Item	Qty
Approved	

product sheet  
updated 11/28/24