



# PFA

FULLY AUTOMATIC VENTLESS  
ELECTRIC COUNTERTOP DEEP FRYER

## KEY FEATURES

- Fully automated cooking system
- Front loading/front dispensing
- Integral ventless design
- Built-in fire suppression
- Large output
- Small footprint
- Fully enclosed
- Odorless
- Easy to clean
- Non-stick basket

## TOUCH CONTROL

- Cook time sensitivity (CTS)<sup>™</sup>
- Preset counters
- Food type sensitivity (FTS)<sup>™</sup>
- Stand by mode
- Dual load cooking with Rapid Fry<sup>™</sup> technology
- Hold time monitor



OPEN   
KITCHEN  
Available

*The Benchmark in Ventless Deep Frying*

**PERFECT FRY COMPANY**

42 Allen Martin Drive, Essex Junction, VT 05452 (802) 658-6600 [www.perfectfry.com](http://www.perfectfry.com)

P/N 84270 Rev F (1/24)

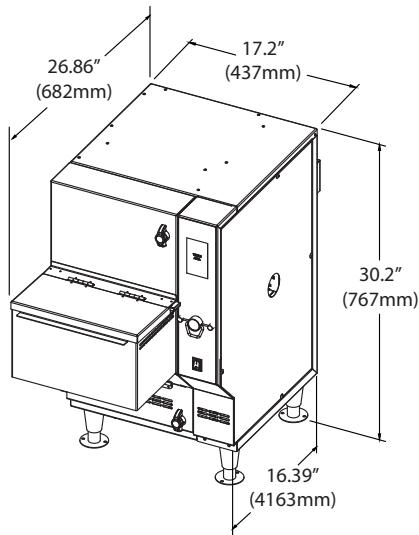

## OPTIONS & ACCESSORIES

- **PERFECT FILTER KIT** - includes (1) Oil Filter unit, hand held oil tester w/storage bracket and 100 disposable filter pads
- **LOCKING DOOR LATCHES** Employee safe guard (must specify on order)
- **HEAT LAMP** - plugs into the back of PFA fryer
- **LOCKING LATCH** - Employee safe guard (must specify on order)
- **AIR FILTER REPLACEMENT KIT** - Includes: (1) replacement air filter
- **FIRE ALARM SIGNAL INTEGRATION**
- **WIFI/CLOUD CONNECTIVITY** Optional wifi module to connect to **Open Kitchen**, allowing remote access and data acquisition.

## COOKING CAPACITY

Oil Capacity	2.9 US Gallons (11 L)
Product Capacity	3 lbs per load (1.3kg)

## WEIGHTS & SHIPPING

Product Weight	134 lbs (60.78 kg)
Shipping Weight	159 lbs (72.12 kg)
Shipping Dimensions	Depth 24" (610 mm) Width 29" (737 mm) Height 36" (914 mm)
Shipping Cube	9.52 ft3 (.271 m3)

## CLEARANCES

Sides	1" (25.4mm)
Back	2" (50.8mm)
Top	0" (0mm)

## ELECTRICAL SPECIFICATIONS

MODEL	VAC	KW	KW W/ OPTIONAL HEAT LAMP	CYCLE	PHASE	AMP	AMP W/ OPTIONAL HEAT LAMP
PFA500	208	5.0	5.4	60	1	24	26
					3	14	15
PFA730	208	7.3	7.7	60	1	35	37
					3	21	22
PFA500	240	5.5	5.9	50/60	1	23	25
					3	14	15
PFA730	240	8.0	8.4	50/60	1	34	35
					3	20	21
PFA500	200	4.7	5.1	50/60	1	24	26
PFA730					1	34	36
PFA500	220	4.6	5.0	50/60	1	21	23
PFA730					1	31	33
PFA500	230	5.0	5.4	50/60	1	22	24
PFA730					1	32	34
PFA500	220/380	4.6	5.0	50/60	3	7	8
PFA730					3	11	11
PFA500	230/400	5.0	5.4	50/60	3	8	8
PFA730					3	11	12
PFA500	240/415	5.5	5.9	50/60	3	8	9
PFA730					3	12	12

For use on an individual branch circuit. Fryer must be properly connected to a grounded, dedicated phase circuit according to local standards and codes.

### \*Cord Set Standard

## DUAL LOAD RAPIDFRY™ TECHNOLOGY

RapidFry™ technology allows the operator to pre-load food into the drawer while other food product is frying in the cooking oil. The second load of food will automatically begin cooking once the first cook cycle is completed.



**PERFECT FRY™  
PORTABLE OIL FILTER**

