

SaniServ®



MADE IN USA

MODEL 709



**104
FROZEN
COCKTAILS/HR**

SUPER PRODUCTION IN A SMALL DESIGN

The SaniServ® model 709 frozen beverage freezer is perfect for providing a high volume of frozen drinks for even the busiest of locations. The increased production makes the model 709 great for providing pitchers of frozen product and supplying plenty of product for larger frozen beverages. With the 709's quick recovery, owners and operators are assured product availability even during peak serving periods!

MODEL 709



Job: _____

Item No. _____



DESIGNED FOR MEDIUM VOLUME APPLICATIONS 13 Gallons per Hour - 20 Quart Capacity

Use SaniServ® Model 709 to Create



Dimensions: Width (17") Depth (24.8")
Height (33") Weight (207 lbs)

Electrical Requirements:
208-230/60/1 = 20 Amps
208-230/60/3 = 15 Amps



About the 709

Cooling Options



Serving Estimate:
Up to 104 Frozen Cocktails / hr

We reserve the right to change specifications and product designs without notice. Such revisions do not entitle the buyer to corresponding changes, improvements, additions, or replacements for previously purchased equipment.

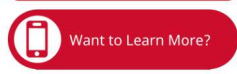

✓ SPACE SAVING - *Small Footprint Design*

SaniServ® model 709 offers increased production without having to come in a larger design! Owners and operators can still save valuable floor space and turn the countertop into a high profit center by providing the frozen beverages customers enjoy!

✓ EASY CLEANING AND OPERATION - *Fewer Parts = Simplified Cleaning*

SaniServ® equipment is designed and built with the fewest parts to be disassembled, cleaned and sanitized than any other machine in the industry. The state of the art solid-state AccuFreeze® control insures product consistency, worry-free operation and customer satisfaction.

✓ HIGH RETURN ON INVESTMENT - *Increased Profits*

SaniServ® machines combine efficiency with consistent product quality and fast, quiet operation while insuring customer satisfaction with high profit frozen beverages.

✓ QUALITY DESIGN

SaniServ® machines are built to achieve long and dependable life through simplicity of design. Every machine is shipped standard with a stainless steel exterior, durable steel interior frame construction, heavy-duty components and consistency systems.

MODEL 709

AccuFreeze[®] CONTROL

Minimum Wall Clearance
Both Sides and Back
6 inches (152 mm)

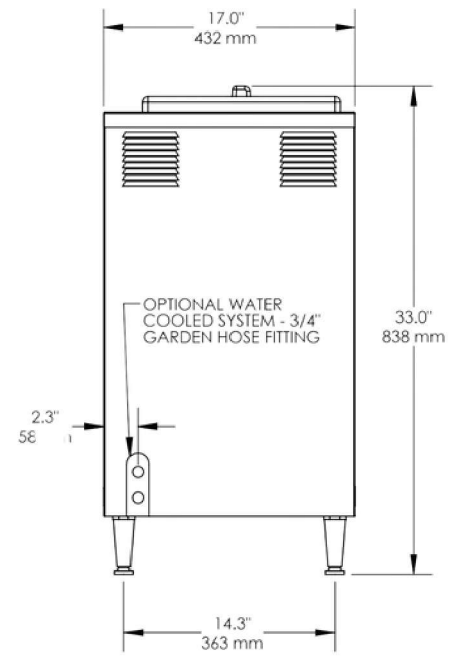
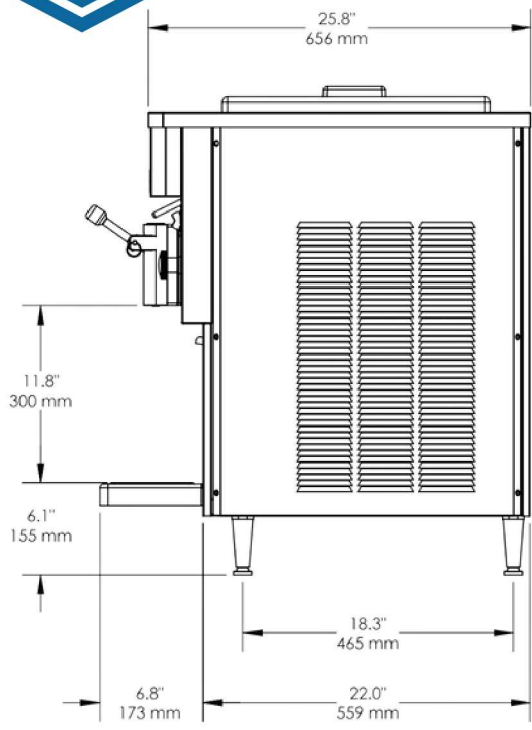
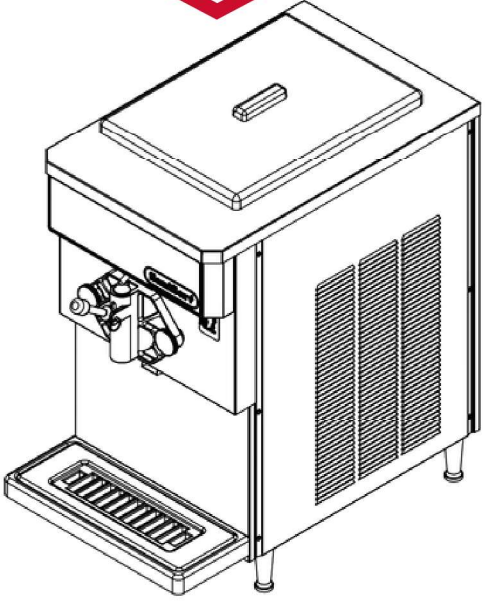

ELECTRICAL				WIDTH	HEIGHT	DEPTH	WEIGHT	VOLUME
VOLTS	Hz	Ph.	Amps	INCHES (MM)	INCHES (MM)	INCHES (MM)	LBS. (Kg)	CU FT. (cu. m.)
208-230	60	1	20	17 (432)	33 (838)	24.8 (630)	207 (94)	
208-230	60	3	15					
Shipping Specifications				22.5 (572)	41 (1042)	34.5 (876)	265 (120)	18.5 (.53)

SPECIFICATIONS

Cooling System:
Air or Water

Dasher and Compressor

Motors:
1/4 HP Dasher
1 HP Compressor

Refrigerator Type:
R404A

Listings:
UL, cUL, NSF

FEATURES

Evaporator and Mix Reservoir Capacity:
20 Quarts (18.9 liters)

Dasher:
Heavy-Duty Stainless Steel with low friction scraper blades.

Controls:
AccuFreeze[®] solid-state control for accurate product consistency.

Solid State Audio/Visual Mix Out System with Compressor Lockout

WARRANTY

Parts	1 year
Compressor	5 years
Evaporator	5 years

Options:
Tune Up Kit
Drink Spinner
Lightbox
Countertop Mounting Pad
Machine Stand
Wash Out Kit - 3/8" Flare Fitting
Water Cooled - 3/4" Garden Hose Fitting
Export Voltages