



Project Name: \_\_\_\_\_ AIA#: \_\_\_\_\_  
 Model #: \_\_\_\_\_ Location: \_\_\_\_\_  
 SIS#: \_\_\_\_\_ Item #: \_\_\_\_\_ Quantity: \_\_\_\_\_

# S213A Premium Automatic Slicer

## Precision Cutting Powerful Performance Easy Cleaning

*The heavy-duty S2-Series of premium slicers from Globe deliver powerful performance in a compact, intuitive design with improved cleanability and Globe-trusted durability.*



S213A

**Model:** S213A (Standard Automatic)

**Standard Features:**

**Cutting System**

- 13" carbon steel knife with hardened edge provides quality slices and higher yields
- Top mounted knife sharpening system offers a user-friendly sharpener with replaceable grit stone, providing a precision knife edge for consistent slicing

**Drive System**

- Variable speed, brushless motor delivers 3ft/lbs of peak torque
- Patented, auto engagement system ensures no slippage when slicing in automatic mode

**Interlocks**

- No-Volt Release interlock prevents inadvertent reactivation of knife in the event of power interruption

**Product Handling**

- Large-capacity carriage accommodates prosciutto, mortadella, and bacon
- Patented meat grip design for superior product hold
- 50° gravity-feed carriage design guides product toward the blade for effortless slicing

**Cleanability**

- Anodized aluminum construction for quick and easy cleaning
- Patented, removable meat grip design allows for easy handling and is dishwasher safe
- Removable upper carriage with lock-and-slide design allows for easy reassembly and unobstructed cleaning access
- Removable knife sharpener for quick and easy cleaning
- Integrated lift lever allows easy access for fast, efficient cleaning

**Structure & Controls**

- Reverse-action cam driven indexing system enables accurate and precise slice thickness adjustments up to 5/8" (0.625"), with optimum control on the thinnest cuts
- Control panel features tactile Start, Stop, Speed, and Stroke buttons as well as power and run indicator lights

**Interface & Diagnostics**

- Patented, graphic user interface with Clear-Text LCD display provides build-in site diagnostics and system counters
- Multi-language interface (English, French, Spanish)
- Selectable dual cut lengths and dual slicing speeds ensure repeatable slice accuracy

**Warranty**

- Two year parts and labor



Approved by: \_\_\_\_\_ Date: \_\_\_\_\_



# S213A Premium Automatic Slicer

## Factory Installed Options



**TAMPER-PROOF  
TORX® SCREWS**

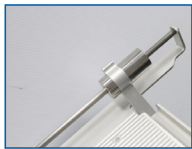

**NON-REMOVABLE  
SLIDE ROD**

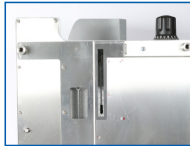

**FULLY ENCLOSED  
BOTTOM**

### Correctional Package (CORR)

- Available for S213 and S213A only
- External fasteners are tamper resistant which can only be removed with a special driver bit supplied with the slicer
- Knife cover, removable carriage and sharpener blank secured with tamper proof screws
- Secured sharpener blank allows real sharpener to be secured away from slicer
- Slide rod and end weight are non-removable
- Bottom cover is secured with tamper proof screws



**DOUBLE  
SERRATED  
KNIFE**



### Frozen Package (FRZN)

- Available for S213 and S213A only
- Slices frozen product between 20° and 32° F, as well as most non-frozen products, max slice width 1/8"
- 13" double serrated steel knife with hardened edge provides quality slices and higher yield
- Slices 30 strokes per minute in automatic mode
- No sharpener included, serrated blades must be replaced



**STAINLESS STEEL BLADE**

### Stainless Steel Blade (SSK)

- Ideal for highly acidic applications commonly found in preparation of onions and citrus fruits
- Resists enzyme/protein exposure in raw red meat slicing to help prevent corrosion and extend blade life
- Offers better corrosion resistance caused by extreme moisture applications (meat rooms)

### S2-Series Premium Model Features

- Compact footprint for space-conscious kitchens
- Lock and slide modular carriage
- Advanced meat grip design
- Lift lever for easy cleaning access
- Anodized aluminum base
- Improved seal cleanability
- Lightweight for portability
- User-friendly interface





# S213A Premium Automatic Slicer Accessories



**S2-FF125**  
Low Food Fence  
(12.125" x 1.125")



**S2-FF300**  
High Food Fence  
(12.125" x 3.00")



**S2-FPA**  
Food Prep Attachment  
(14.00" x 7.76")



**SC-LARGE**  
Slicer Sanitation Cover



**S-XDSL M**  
Extended 3-Year Warranty

## S2-Series Features, Options & Accessory Guide

FEATURE	S213	S213A	SG213	SG213A
Lock and Slide Removable Carriage	■	■	■	■
Removable Carriage Interlock			■	■
Home to Start (Carriage must be in Home position for blade to rotate)			■	■
Home Return				■
Time Out (Blade will stop running if not in use)*			■	■
Close to Stop (Blade will stop running when gauge plate is closed)			■	■
LCD Display		■	■	■
Site Diagnostics		■	■	■
System Counters		■	■	■
No Volt Release	■	■	■	■
Slicing Length Settings		2		3
Slicing Speed Settings		2		4
<b>CORR</b> - Correctional Package (Factory Option)**	■	■		
<b>KNIFE-RMV</b> - Removable Knife (Factory Option)			■	■
<b>FROZEN</b> - Frozen Package (Factory Option)***	■	■		
<b>SSK</b> - Stainless Steel Knife (Factory Option)****	■	■	■	■

\*Time Out is programmable. Factory setting is 30 seconds.

\*\*Correctional package has a fixed carriage

\*\*\*Frozen package has a max slice thickness of 1/8"

\*\*\*\*Made from SS430 stainless steel



# S213A Premium Automatic Slicer

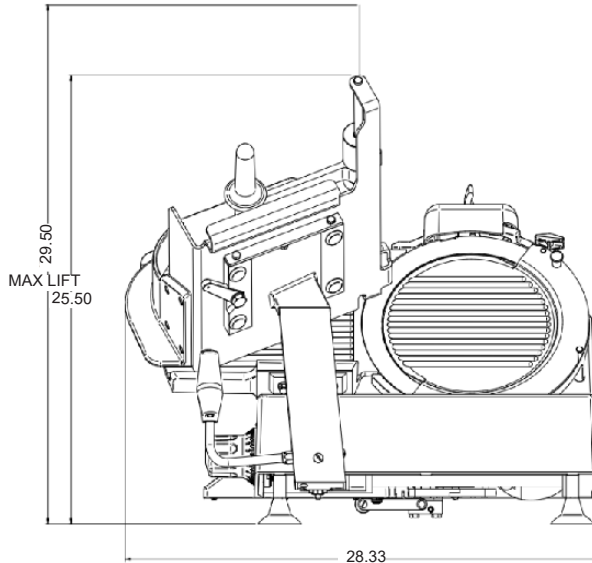
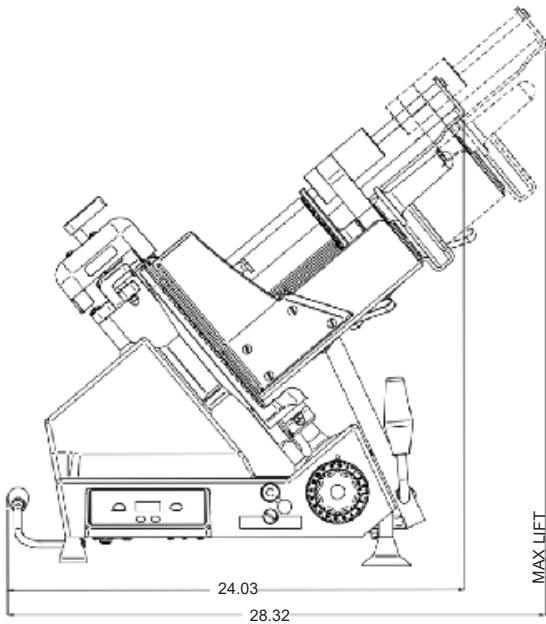

UNIT: Inches

Drawings available through KCL. [www.kclcad.com](http://www.kclcad.com)

## SPECIFICATIONS

Model	Motor	Volts	Amps	NEMA Plug Type	Drive Type	Slicing Vol. / Day	Cheese Slicing	Blade Diameter	Max Slice	Product Cutting Capacity		
										D (Diameter)	H (Height)	W (Width)
<b>S213A</b>	1/2 HP	110-60-1	2	5-15	Poly-V Belt	All Day	100%	13" (33.02 cm)	5/8" * (1.8588cm)	7.5" (20.32cm)	13.75" (35 cm)	11" (27.94 cm)

Cord & Plug: Attached 7 ft. flexible 3-wire cord with molded plug fits a grounded receptacle.

## DIMENSIONS | SHIPPING INFORMATION

Reinforced carton for shipping. The weight and dimensions of this reinforced carton are included below and may vary from shipment to shipment.

**Shipped on a pallet. Freight class 85.**

Model	Max Overall Dimensions	Net Weight	Shipping Dimensions	Shipping Weight
<b>S213A</b>	22" W x 28.3" D x 24.8" H (55.9 cm x 71.9 cm x 63 cm)	91 lbs. (40.8 kg)	32" W x 31.5" D x 30.5" H (81.3 cm x 80 cm x 77.5 cm)	131 lbs. (59.4 kg)

### FACTORY INSTALLED OPTIONS:

- CORR - Correctional Package
- FRZN - Serrated knife in lieu of standard knife and additional modifications
- SSK - Stainless steel knife in lieu of Carbon Steel

### OPTIONAL ACCESSORIES:

- S2-FF125 - Food Fence Low, 1.25"
- S2-FF300 - Food Fence High, 3.00"
- S2-FPA - Food Prep Attachment
- SC-LARGE - Sanitation Cover
- S-XDSLML - Extended 3-Year Warranty

Constructed of durable anodized aluminum for quick, easy cleaning and long service life, the S213A features a 13" carbon steel knife with a hardened edge to deliver consistent, high-quality slices and improved yield. A top-mounted sharpening system with a removable sharpener and replaceable grit stone maintains a precision edge. Slice thickness is managed by reverse-action, cam-driven indexing for accurate control up to 5/8" (0.625"). For high-performance automatic slicing, the S213A is powered by a variable-speed, brushless 1/2 HP drive system delivering up to 3 ft/lbs of peak torque, with overload protection and a patented auto-engagement system to prevent slippage in automatic mode. The large-capacity 50° gravity-feed carriage handles products such as prosciutto, mortadella, and bacon, supported by a patented meat grip for superior product hold. Cleanability features include a removable upper carriage (lock-and-slide), dishwasher-safe removable meat grip, removable sharpener, and an integrated lift lever for faster sanitation. The operator interface includes tactile Start/Stop/Speed/Stroke controls with indicator lights, plus a patented Clear-Text LCD with built-in diagnostics, and system counters. Multi-language support (English/French/Spanish) and selectable dual cut lengths and dual slicing speeds help ensure repeatable results. Interlocks include No-Volt Release to prevent inadvertent restart after power interruption. ETL listed. Backed by a two-year parts and labor warranty.