



# Owner's Manual

FOR THE TURBOCHEF HIGH H BATCH 2™ RAPID COOK OVEN





---

MODEL

---

SERIAL NUMBER

---

INSTALLED BY

---

INSTALLATION CHECKED BY

---

SERVICE CENTER NAME / NUMBER

*For service or information:*

WITHIN NORTH AMERICA CALL

**Customer Service at 1-800-90TURBO**

OUTSIDE NORTH AMERICA CALL

**+1-214-379-6000 or Your Authorized Distributor**



The information contained in this manual is important for the proper installation, use, maintenance, and repair of this oven. Follow these procedures and instructions to ensure satisfactory baking results and years of trouble-free service.

Errors – descriptive, typographic, or pictorial – are subject to correction. Specifications are subject to change without notice.

**Please carefully read this manual and retain it for future reference.**

# Table of Contents

<b>Important Safety Instructions</b>	<b>i</b>
Important Safety Instructions – Please Read First	i
General Safety Information	i
Reducing Fire Risk	i
Preventing Oven Damage	ii
Grounding Instructions	ii
Power Cord Replacement	ii
<b>Specifications and Installation</b>	<b>1</b>
Theory of Operation	1
Certifications	1
Dimensions	1
Construction	2
Exterior	2
Interior	2
Electrical Specifications	2
United States	2
Canada	2
Latin America	2
Europe/Asia/Pacific	2
United Kingdom/Ireland	2
Standard Features	3
Performance	3
Installation	3
Packaging	3
Damaged Shipment Claims	3
Lifting and Placing the Oven	3
Securing Oven to Cart	5
Double Stacking Ovens	5
Built-in Installation	5
Installation Near Open Heat Source	6
Setup	6
Ventilation Requirements	6
Optional Installation Items	7
Oven Restraint Kit	7
Oven Cart	7
Replacing/Exchanging Jetplates	8

<b>Oven Maintenance</b>	<b>9</b>
Daily Cleaning	9
Deep Cleaning	10
<b>Operating the Oven</b>	<b>12</b>
Control Display and Key Identification	12
Cooking Instructions	13
Additional Cooking Options	14
Time Screen	14
Done Screen	14
Options Menu	14
Enabling/Disabling the Edit Menu	15
Erasing the Recipe Menu	15
Enabling/Disabling the Write Card Function	16
Enabling/Disabling the Time Screen	16
Enabling/Disabling the Done Screen	17
Enabling/Disabling the Demonstration Mode	17
Programming Recipes	18
Adjusting the Cook Chamber Temperature	18
Modifying Recipes	18
Ordering a Smart Card	20
Loading Menu from Smart Card	20
Saving Menu to Smart Card	20
Checking Recipe Counter	20
<b>Troubleshooting Tips</b>	<b>22</b>
Recording the Serial Number	22
Recording Error Messages	22
Checking the Fault Log	22
Common Issues and Solutions	22
Table of Common Issues and Solutions	23
<b>North America Limited Warranty</b>	<b>24</b>
<b>International Limited Warranty</b>	<b>27</b>

## IMPORTANT SAFETY INSTRUCTIONS

 **WARNING:** When operating this oven, strictly adhere to all safety precautions below, on page ii, and throughout this manual to reduce the risk of burns, electric shock, fire, injury, oven damage, or property damage. Improper installation, adjustment, alteration, service, or maintenance of this equipment can cause property damage, injury, or death. Thoroughly read the installation, operating, and maintenance instructions before installing or servicing this equipment.

### General Safety Information

- Use this appliance only for its intended uses as described in this manual.
- Only qualified service personnel should service this appliance. Contact the nearest authorized service facility for examination, repair, or adjustment.
- Always ensure the oven is disconnected from the power supply before servicing, repairing, or adjusting any components or parts.
- ❑ DO NOT place the cord near heated surfaces.
- ❑ DO NOT store or use flammable vapors or liquids (e.g., gasoline) in the vicinity of this appliance.
- ❑ DO NOT allow children to use this appliance.
- ❑ DO NOT place corrosive chemicals or vapors in this appliance. It is not designed for industrial or laboratory use.
- ❑ DO NOT operate this appliance if it
  - Has a damaged cord or plug
  - Is not working properly
  - Has been damaged or dropped
- ❑ DO NOT cover or block any openings on this appliance.
- ❑ DO NOT store this appliance outdoors.
- ❑ DO NOT use this appliance near water.
- ❑ DO NOT immerse this appliance or any of its components (e.g., cord, plug, etc.) in water.
- ❑ DO NOT let the cord hang over the edge of a table or counter.

### Reducing Fire Risk

If materials inside the oven ignite or if smoke is observed:

1. Keep the oven door closed.
2. Turn off the oven.
3. Disconnect the power cord or shut off power at the fuse/circuit breaker panel.

- Carefully attend the oven if paper, plastic, or other combustible materials are placed inside to facilitate cooking.
- ❑ DO NOT leave items in the cook cavity when the oven is not in use.
- ❑ DO NOT cook items wrapped in cling wrap or plastic film.
- ❑ DO NOT overcook food.

## Preventing Oven Damage

- Clean the oven daily (page 9). Failure to do so will adversely affect cooking performance and shorten the life of the oven.
- Once per month or more frequently depending on use, perform the deep cleaning procedure (pages 10-11). Failure to do so will adversely affect cooking performance and shorten the life of the oven.
- Clean the oven only with TurboChef Oven Cleaner.
- Operate the oven only when food is in the cook chamber.
- ▣ DO NOT clean with a water jet.
- ▣ DO NOT slam or mishandle the oven door.
- ▣ DO NOT frequently open and close the door to check the cook status of the food.
- ▣ DO NOT allow cleaning solution or water to remain in the cook chamber after cleaning or at any other time.
- When servicing this appliance, do not tear insulation to get to components. Rather, find the edge of the insulation and remove the tape that holds it in place.

## Grounding Instructions



**WARNING:** Improper grounding increases the risk of electric shock.

This appliance must be grounded. It is equipped with a cord that has a grounding wire and plug, which in the event of an electrical short circuit reduce the risk of electric shock by providing an escape wire for the electric current. The wire must be plugged into an outlet that is properly installed and grounded. Consult a qualified electrician or serviceman for more information on grounding instructions or to determine if the appliance is properly grounded.

- ▣ DO NOT use an extension cord. If the power supply cord is too short, ask a qualified electrician or serviceman to install an outlet near the appliance.

## Power Cord Replacement

To avoid potential hazards, only the manufacturer, an authorized service agent, or a similarly-qualified person should replace a damaged power cord.

# Specifications and Installation

## Theory of Operation

The TurboChef High h Batch 2™ oven generates high heat transfer rates to rapidly cook food by recirculating impinged air at speeds of up to 60 mph. The technology includes utilizing a variable speed blower, oscillating rack, and catalytic converter, resulting in minimal energy input, high food quality, and UL-certified ventless operation.

## Certifications

UL, cUL, NSF, TÜV, CE



UL 710B (KNLZ) listed for ventless operation.

## Dimensions

### Single Units

Height	17.4"	(442 mm)
with legs*	21.4"	(544 mm)
without legs	17.4"	(442 mm)
Width	25.9"	(658 mm)
Depth	29.2"	(742 mm)
with handle	31.7"	(805 mm)
Weight	157 lb.	(71 kg)

### Double Units (Requires a Stacking Kit)

Height		
top w/ legs	42.8"	(1087 mm)
top w/out legs	38.8"	(986 mm)
Width	25.9"	(658 mm)
Depth	29.2"	(742 mm)
with handle	31.7"	(805 mm)
Weight	314 lb.	(142 kg)

\* Legs are 4" (102 mm)

### Cook Cavity

Height	8"	(203 mm)
Width	18.75"	(476 mm)
Depth	16.75"	(425 mm)
Volume	1.45 cu. ft.	(41.1 liters)

### Wall Clearance

Top	2"	(51 mm)
Sides	2"	(51 mm)

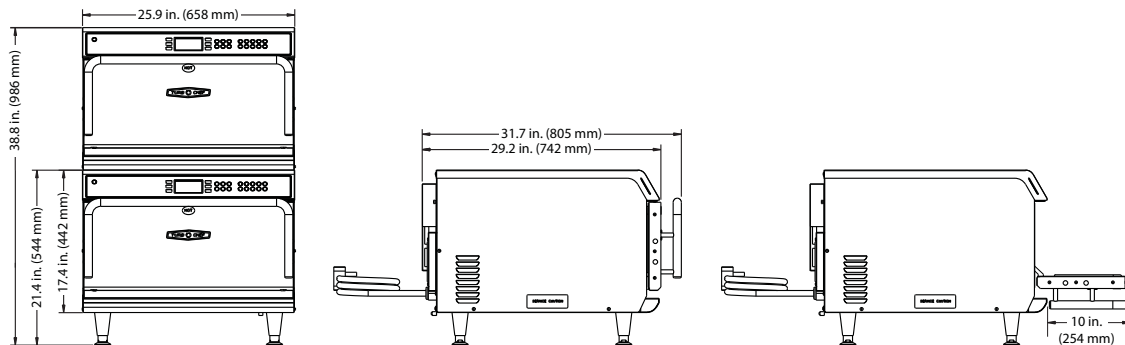

FIGURE 1: High h Batch 2 Dimensions

## Construction

### Exterior

- Stainless steel front, top, back, and powder-coated sides
- 4" (102 mm) matte black legs
- Ergonomic, cool to touch powder-coated door handle

### Interior

- 304 stainless steel interior
- Water-tight construction
- Interchangeable jetplates for customized cooking results

## Electrical Specifications

### United States

- HHB (P/N: HHB-8603-1)
 

Phase	1
Voltage*	208/240 VAC
Frequency	50/60 Hz
Current	24 amps
Max Circuit	30 amps
Max Input	5000 watts
Cord	10 gauge, 3 wire, 6 foot, SOOW
Plug	NEMA 6-30P

### Canada

- HHBC (P/N: HHB-8603-1C)
 

Phase	1
Voltage*	208/240 VAC
Frequency	50/60 Hz
Current	24 amps
Max Circuit	50 amps
Max Input	5000 watts
Cord	10 gauge, 3 wire, 6 foot, SOOW
Plug	NEMA 6-50P

\*Smart Voltage Sensor Technology automatically senses the supply voltage and prompts the operator to configure the oven to the correct setting (208 or 240). However, it does not compensate for lack-of or over voltage situations.

### Latin America

- HHBLA (P/N: HHB-8603-1K-2073)
 

Phase	1
Voltage	230 VAC
Frequency	50/60 Hz
Current	24 amps
Max Circuit	30 amps
Max Input	5000 watts
Cord	10 gauge, 3 wire, 6 foot, SOOW
Plug	NEMA 6-30P

### Europe/Asia/Pacific

- HHBEW (P/N: HHB-8603-1W)
 

Phase	3
Voltage	400 VAC
Frequency	50/60 Hz
Current	10 amps
Max Circuit	16 amps
Max Input	5000 watts
Cord	HO7RN-F, 5 wire
Plug	IEC 309, 5-pin, 16 amp
- HHBED (P/N: HHB-8603-1D)
 

Phase	3
Voltage	230 VAC
Frequency	50/60 Hz
Current	18 amps
Max Circuit	20 amps
Max Input	5000 watts
Cord	HO7RN-F, 4 wire
Plug	IEC 309, 4-pin, 32 amp

### United Kingdom/Ireland

- HHBUK (P/N: HHB-8603-1K)
 

Phase	1
Voltage	230 VAC
Frequency	50/60 Hz
Current	24 amps
Max Circuit	30 amps
Max Input	5000 watts
Cord	HO7RN-F, 3 wire
Plug	IEC 309, 3-pin, 32 amp

NOTE: The owner is responsible for supplying voltage that meets the above specifications. For more information, consult a qualified electrician.

## Standard Features

- Integral recirculating catalytic converter for UL listed ventless operation (UL KNLZ)
- Interchangeable top and bottom jetplates for product specific cooking
- Variable-speed High h recirculating impingement airflow system
- Oscillating rack for high heat transfer without spotting
- Half-sheet pan/16-inch pizza capacity
- Smart Voltage Sensor Technology\* (U.S. only)
- Stackable design (requires stacking kit)
- Smart menu system capable of storing up to 72 recipes
- Built-in self diagnostics for monitoring oven components and performance
- Includes plug and cord (5 ft.)
- Warranty - 1 year parts and labor

## Performance

- Heat transfer rates (h) are 3X–4X typical convection oven
- Heat transfer rates (h) are 2X typical conveyor oven

## Installation

Install or locate this appliance only in accordance with the instructions provided below and on pages 4-6.

## Packaging

All ovens are packaged in a double-wall corrugated box with integrated skids. If it is possible the oven may be shipped from its original place of installation for any reason, TurboChef recommends retaining the packaging in good condition.

## Damaged Shipment Claims

Upon delivery, remove oven from its packaging and immediately note any damage. To file a claim, contact the shipping company within 24 hours of receiving the shipment. TurboChef is not responsible if a product is damaged during shipment.

## Lifting and Placing the Oven

 **WARNING:** Oven weight is approximately 157 lb. (71 kg). Two or more persons are required to lift it.

 **WARNING:** To prevent personal injury or damage to the oven, DO NOT lift the oven from the front and rear or by the handle.

 **WARNING:** Ensure the oven is properly placed on the table or countertop at all times. TurboChef will not recognize a fallen oven as a warrantable claim and is not liable for any injuries that may result.

When lifting and placing the oven:

1. Position one or more persons on left and right sides of oven.
2. Lift from bottom of oven.
3. Place oven on surface at least 30" (762 mm) deep and capable of supporting 167 lb. (76 kg).

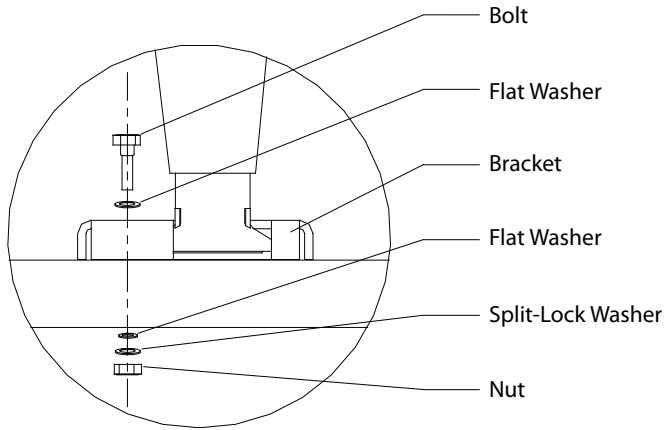

FIGURE 2: HHB 2 Oven Secured to TurboChef Oven Cart

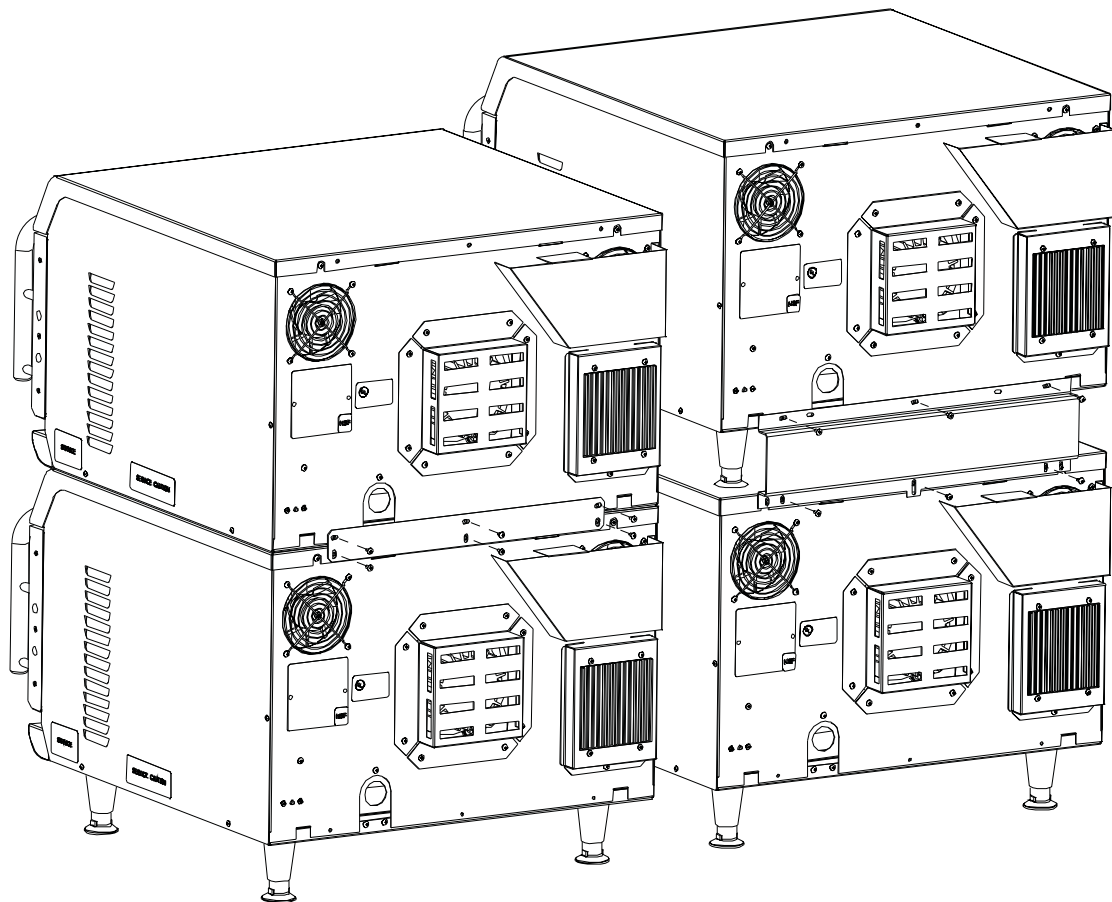

FIGURE 3: Stacked HHB 2 Ovens (Two Configurations)

**Securing Oven to Cart**

Reference Figure 2, adjacent.

1. Lock the oven cart wheels.
2. Place the oven on the cart.

**⚠ WARNING:** Do not attempt to lift the oven with fewer than 2 people.

**⚠ WARNING:** When lifting the oven, position at least one person on each side. Do not lift the oven from the front and back, and do not use the handle to lift the oven.

**⚠ WARNING:** Do not transport ovens on cart when stacked.

4. Attach one oven cart bracket to each leg (kit HHB-8206 includes four brackets).
5. Secure each leg by aligning the bracket with the holes on the oven cart and attaching the parts listed in Figure 2.

**Double Stacking Ovens**

1. Ensure the surface that will hold the stacked ovens can support the weight (314 lb./142 kg).
2. Allow each oven time to cool and then unplug.
3. If stacking ovens on an oven cart, make sure the bottom oven is bolted to the cart and the wheels are locked (Figure 2).
4. Attach the stacking bracket to the back of the bottom oven using the existing oven screws as shown in Figure 3.
5. Remove the screws from the top oven, as shown in Figure 3.
6. If desired, remove the legs from the top oven.

NOTE: Ovens can be stacked either with legs attached or removed from the top oven.

7. Place the top oven on the bottom oven.

**⚠ WARNING:** Do not attempt to lift the oven with fewer than 2 people.

**⚠ WARNING:** When lifting the oven, position at least one person on each side. Do not lift the oven from the front and back, and do not use the handle to lift the oven.

8. Align the holes on the stacking bracket with the holes on the top oven and reinstall the screws.

**⚠ WARNING:** Do not stack ovens more than two-high.

**Built-In Installation**

TurboChef ovens are designed to be installed on a countertop or table. They are not intended for built-in or enclosed installation.

“Built-in or enclosed installation” is defined as installing an oven in any structure that surrounds the oven by five sides (top/rear/base/side panels).

If installation must be “built in,” the operator must ensure the following (see Figure 4):

- At least 300 cfm (8.5 cmm) of supplement flow within the cabinet.
- At least 2" (51 mm) clearance to every surface.

The operator will be responsible for compensating any extra time required to service the product due to removing the product for serviceability.

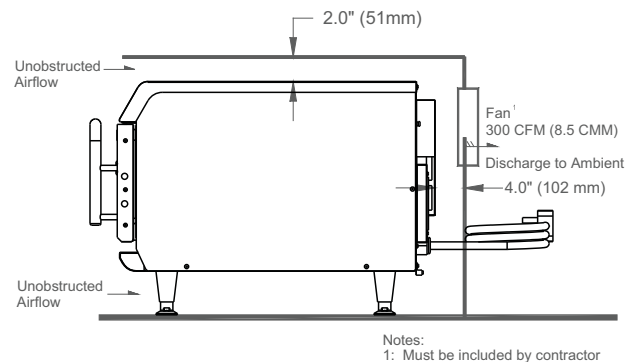
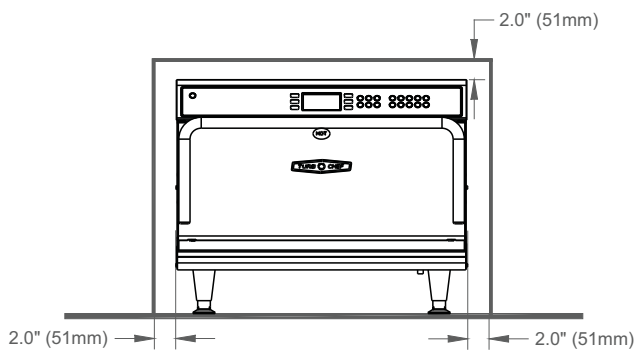

FIGURE 4: Built-in Installation

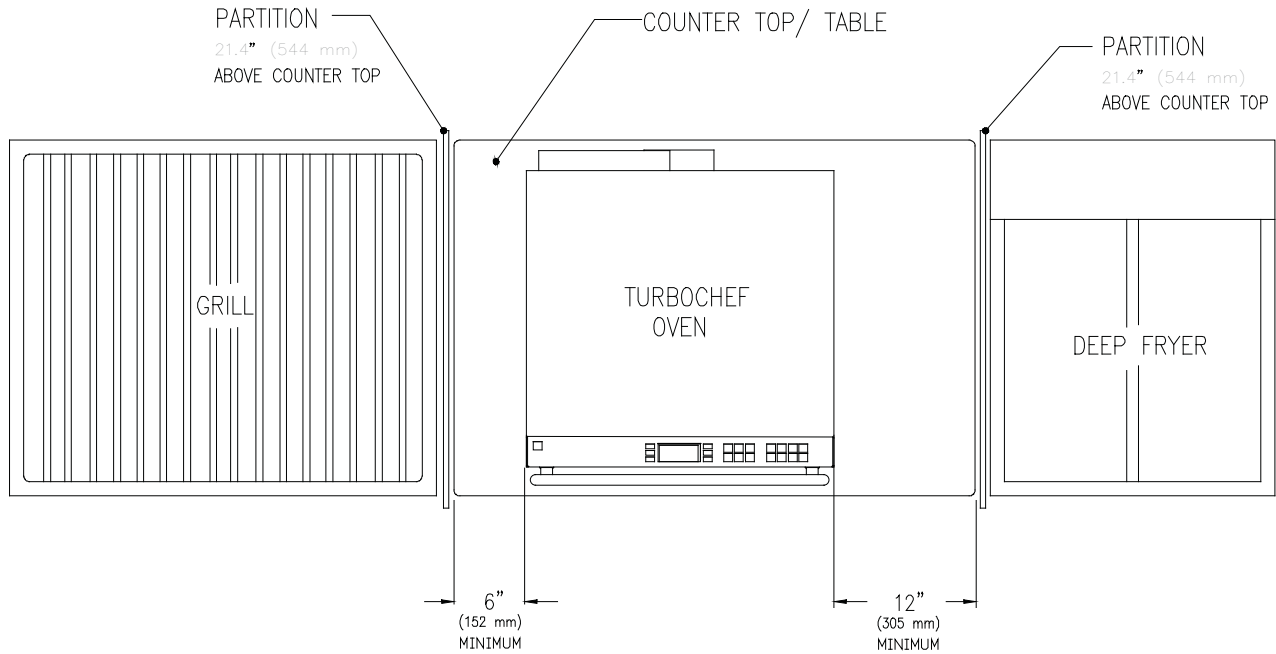

FIGURE 5: Installation Near Open Heat Source

### Installation Near Open Heat Source

When placing a TurboChef oven near an open heat source, strictly adhere to the following (Figure 5):

- Verify oven location has a minimum 6" (152 mm) clearance on top and minimum 2" (51 mm) of clearance on each side.
- If the oven is being placed near a grill or stove, there must be a divider between the oven and the open heat source, with a minimum of 6" (152 mm) between the oven and the divider.
- If the oven is being placed near a fryer, there must be a divider between the oven and fryer, with a minimum of 12" (305 mm) between the oven and the divider.
- The height of the divider must be greater than or equal to the height of the oven (21.4"/544 mm).

### Setup

Once the oven is properly positioned on the counter:

1. Remove packing material from the cook cavity.
2. Install the oven rack by placing it over the support pins.
3. Plug the oven into a wall-mounted electrical receptacle. (See Electrical Specifications, page 2.)
4. The oven has been preprogrammed with factory settings and is ready to operate out of the box.

### Ventilation Requirements

The TurboChef High h Batch 2 oven has been approved by Underwriter's Laboratory for ventless operation (UL 710B, KNLZ listing) for all food items except for foods classified as "fatty raw proteins." Such foods include bone-in, skin-on chicken, raw hamburger meat, raw bacon, raw sausage, steaks, etc. If cooking these types of foods, consult local HVAC codes and authorities to ensure compliance with ventilation requirements.

NOTE: In no event shall the manufacturer assume any liability for damages or injuries resulting from installations which are not in compliance with the instructions and codes previously listed.

### Optional Installation Items

#### Oven Restraint Kit (P/N: TC3-0242 KIT)

The oven restraint kit is an optional device that prevents the oven from moving forward during use and cleaning. It will not prevent the oven from falling off a countertop if the oven is pulled off or the legs are allowed to slide off the edge. Call 1-800-90TURBO or your Authorized Distributor for more information.

#### Oven Cart

##### Construction

- Available heights: 18" (457 mm) or 24" (610 mm)
- 304 stainless steel
- 14-gauge 304 stainless steel top
- 16-gauge 304 solid stainless steel shelf
- Four 6" (152 mm) high polyurethane tired casters, front two with safety locking brakes; bolt-on to stainless steel leg

##### Standard Features

- Reinforcement: Welded gusset plates between legs and top to ensure rigidity/eliminate stand racking
- Frame: Fully welded 1.5" x 1.5" (38 mm x 38 mm) square stainless steel tube
- Easy to assemble

Call 1-800-90TURBO or your Authorized Distributor for more information.

#### 18" (457 mm) Oven Cart Dimensions

Height	18"	(457 mm)
with single oven	39.4"	(1001 mm)
with stacked ovens*		
top unit without legs	56.8"	(1443 mm)
top unit with legs	60.8"	(1544 mm)
Width	27.8"	(706 mm)
with single oven	27.8"	(706 mm)
with stacked ovens*	27.8"	(706 mm)
Depth	26.625"	(676 mm)
with single oven	31.7"	(805 mm)
with stacked ovens*	31.7"	(805 mm)

#### 24" (610 mm) Oven Cart Dimensions

Height	24"	(610 mm)
with single oven	45.4"	(1153 mm)
with stacked ovens*		
top unit without legs	62.8"	(1595 mm)
top unit with legs	66.8"	(1697 mm)
Width	27.8"	(706 mm)
with single oven	27.8"	(706 mm)
with stacked ovens*	27.8"	(706 mm)
Depth	26.625"	(676 mm)
with single oven	31.7"	(805 mm)
with stacked ovens*	31.7"	(805 mm)

\*Requires Stacking Bracket.

Assembly instructions are included with the cart. If additional help is needed, call 1-800-90TURBO or your Authorized Distributor.

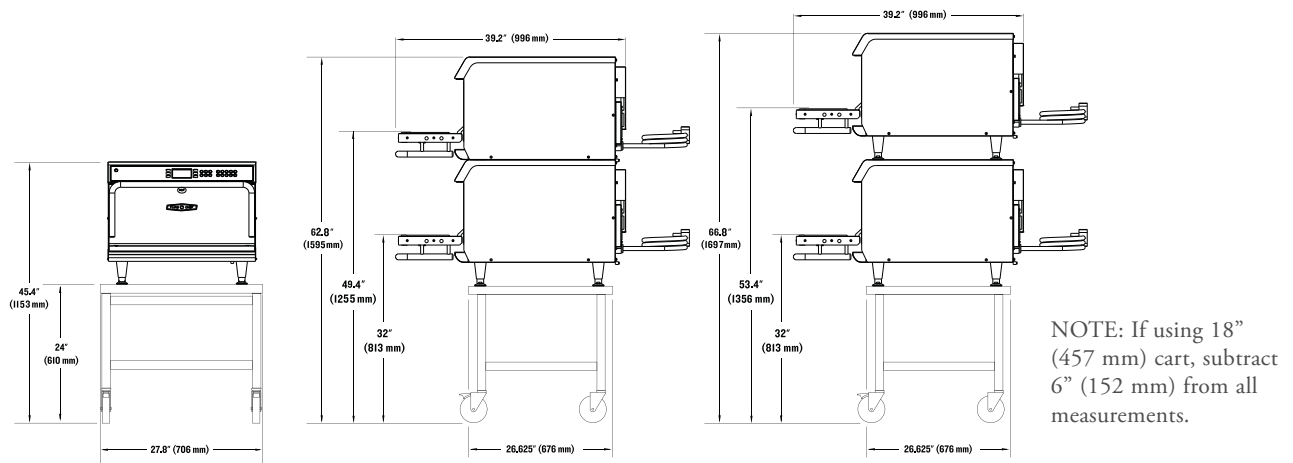

FIGURE 6: 24" (610 mm) Oven Cart with Oven(s)

## Replacing/Exchanging Jetplates

Reference Figure 7. The top and bottom jetplates ensure hot air is distributed evenly to maximize food quality. For product-specific results, jetplates with different hole patterns can be installed.

To remove the bottom jetplate:

1. Ensure the oven is off/cooling down and the cook cavity temperature is below 150°F (66°C).
2. Remove the oven rack.
3. Remove both lower support rails.
4. Remove the lower jetplate.

To remove the top jetplate:

1. Ensure the oven is off/cooling down and the cook cavity temperature is below 150°F (66°C).
2. Remove the oven rack.
3. Remove the filter bracket.
4. Remove both upper support rails.
5. If additional clearance is required, remove the air diverter from the rear oven wall using a Phillips screwdriver.
6. Remove the top jetplate.

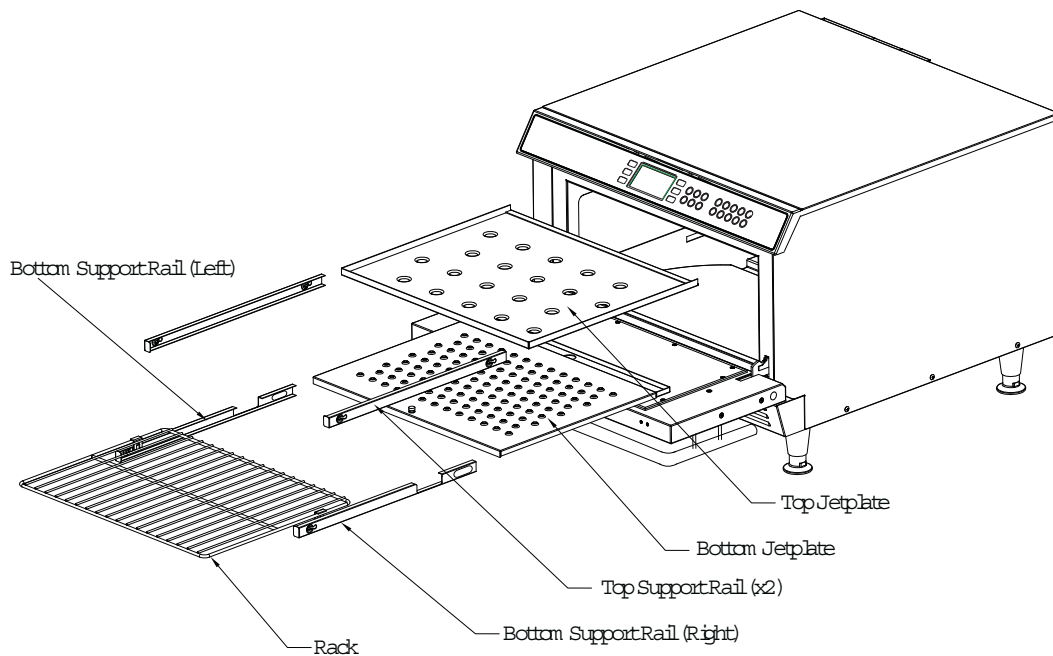
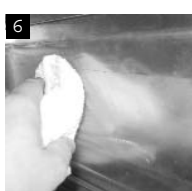
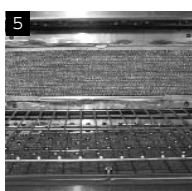
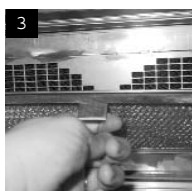

FIGURE 7: Removing Jetplate

# Oven Maintenance

The daily and deep cleaning procedures below will help maintain the High h Batch 2 oven. Be sure to use only TurboChef Oven Cleaner; any other cleaner can damage and void the warranty on critical parts. To order TurboChef Oven Cleaner, Oven Guard, or a new filter, call 1-800-90TURBO, +1-214-379-6000, or your Authorized Distributor.



**Supplies and Equipment:** TurboChef Oven Cleaner (P/N: 103180), Oven Guard (P/N: 103181), nylon scrub pad, cleaning towel, soft-bristle cleaning brush, Phillips screwdriver (only if required for top jetplate removal)

## Step 1: Prepare the Oven.

- Ensure the oven is turned off – press the ON/OFF key.
- DO NOT attempt to clean the oven until the display reads “Ready to Clean.”

**⚠ WARNING:** Injury can occur if the oven is not allowed to cool properly before cleaning.

## Step 2: Remove the Oven Rack.

- Wash, rinse, sanitize, and dry the oven rack.

## Step 3: Clean the Grease Filter.

- Grasp the filter latch and lift and pull out until the filter and bracket lie flat (Figure 3).
- Remove the filter from the bracket and gently rinse it.

**⚠ CAUTION:** DO NOT scrub the filter or use a water jet when cleaning.

- If required, replace the filter (HHB-8287) if it has large holes or is becoming detached from the frame.

## Step 4: Clean the Oven Door and Cook Chamber.

- Using a damp towel, remove food particles.
- For stubborn stains, spray Oven Cleaner and allow it to penetrate for 5 minutes.
- Scrub with a nylon scrub pad.
- Wipe the oven door and cook chamber with a clean damp towel.
- Using a clean dry towel, thoroughly dry the cook chamber.

## Step 5: Reinstall the Grease Filter and Oven Rack.

## Step 6: Apply Oven Guard

- Follow instructions on bottle.

## Step 7: Wipe the Oven Exterior with a Clean Damp Towel.

**⚠ CAUTION:** DO NOT spray chemicals into any openings, such as the louvers on the side panels or the cooling fans on the back of the oven. Doing so can damage critical oven components, resulting in a non-warranty service call.

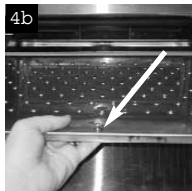
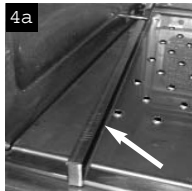
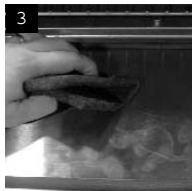
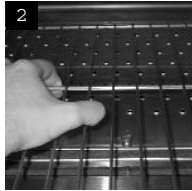

## Deep Cleaning

TurboChef recommends deep-cleaning once per month, or more frequently depending on oven use.

### Step 1: Prepare the Oven.

- Ensure the oven is turned off – press the ON/OFF key.
- DO NOT attempt to clean the oven until the display reads “Ready to Clean.”

**⚠ WARNING:** Possible injury can occur if the oven is not allowed to cool properly before cleaning.

### Step 2: Remove the Oven Rack.

- Wash, rinse, sanitize, and dry the oven rack.

### Step 3: Clean the Oven Door.

- Using a damp towel, remove food particles.
- For stubborn stains, spray Oven Cleaner and allow it to penetrate for five minutes.
- Scrub with a nylon scrub pad.
- Wipe the oven door with a clean damp towel.

### Step 4: Remove the Bottom Jetplate.

- Remove the left and right support rails by gently pulling the rail out, then toward the middle of the oven (Figure 4a), and then out again.
- Remove the bottom jetplate by gripping the thumb screw and lifting up and out (Figure 4b).
- Wash, rinse, sanitize, and dry the bottom jetplate and both support rails.

### Step 5: Remove the Grease Filter and Bracket.

- Grasp the filter latch and lift and pull out until the filter and bracket lie flat (Figure 5a).
- Lift the right side of the filter bracket until you are able to remove it (Figure 5b).
- Remove the filter from the bracket and gently rinse it.

**⚠ CAUTION:** DO NOT scrub the filter or use a water jet when cleaning.

- Wash, rinse, sanitize, and dry the filter bracket.
- Insert the filter back into the bracket. If required, replace the filter (HHB-8287) if it has large holes or is becoming detached from the frame.

*Continued on page 11.*

### Step 6: Remove the Upper Jetplate.

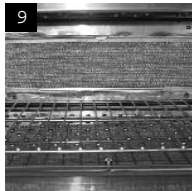
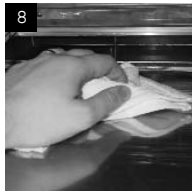
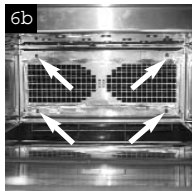

- Remove both upper support rails by pulling the peg (Figure 6a).
- Remove the upper jetplate. If additional clearance is required, remove the air diverter using a Phillips screwdriver (Figure 6b).
- Wash, rinse, sanitize, and dry the upper jetplate and support rails.

#### Step 7: Clean the Cook Chamber.

 **CAUTION: DO NOT** spray Oven Cleaner directly on the back oven wall. Doing so may damage critical oven components, resulting in a non-warranty service call.

- Spray Oven Cleaner to break up stubborn stains and allow it to penetrate for five minutes.
- Scrub with a nylon scrub pad.
- Clean the cook chamber thoroughly with a clean damp towel.

#### Step 8: Dry the Cook Chamber.

- Using a clean dry towel, thoroughly dry the cook chamber.

 **CAUTION: DO NOT** operate the oven with water, cleaner, or debris in the bottom of the cook chamber.

#### Step 9: Reinstall all Clean Parts.

- Reinstall in the following order:
  1. Air diverter (if removed)
  2. Upper jetplate
  3. Upper support rails
  4. Bottom jetplate
  5. Lower support rails
  6. Grease filter and bracket
  7. Oven rack

#### Step 10: Apply Oven Guard.

- Follow instructions on the bottle.

#### Step 11: Clean the Cooling Fan Housing

- Using a dry soft-bristle brush, clean the rear cooling fan housing.

#### Step 12: Wipe the Oven Exterior with a Clean Damp Towel.

 **CAUTION: DO NOT** spray chemicals into any openings, such as the louvers on the side panels or the cooling fan openings on the back of the oven. Doing so can damage critical oven components, resulting in a non-warranty service call.

# Operating the Oven

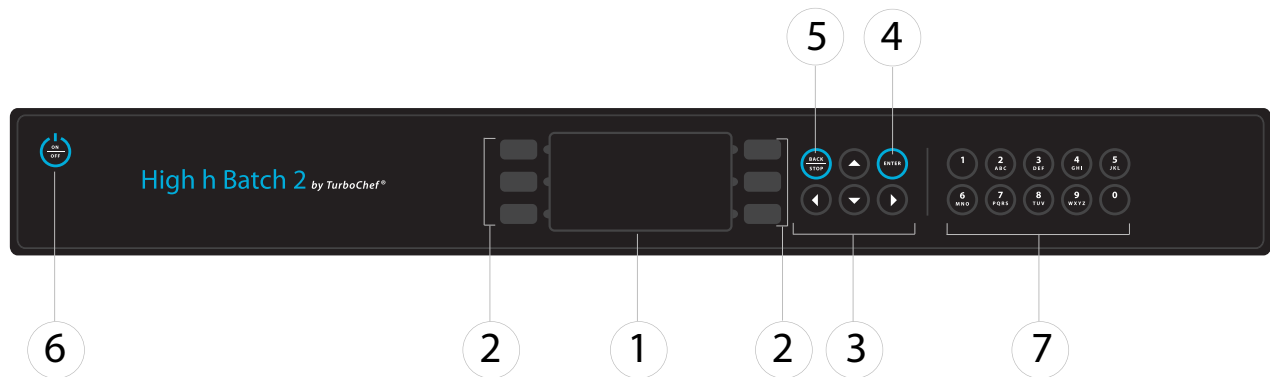

FIGURE 8: High h Batch 2 Keypad

This section contains information on:

- Control display and key identification
- Cooking instructions
- Additional cooking options
- Programming recipes
- Using the Options menu

## Control Display and Key Identification

Reference Figure 8.

### 1. Display

Displays operational information.

### 2. Soft keys (6)

Press to select an option on the screen that is displayed adjacent to key.

### 3. Directional keys

Press to navigate menus and adjust incremental settings, where applicable.

### 4. Enter key

Press to save edited information.

### 5. Back/Stop key

Press to stop a cook cycle or return to a previous screen.

### 6. On/Off key

Press to turn the oven on and off.

### 7. Numeric Keypad

Modifies cook settings in Edit mode.

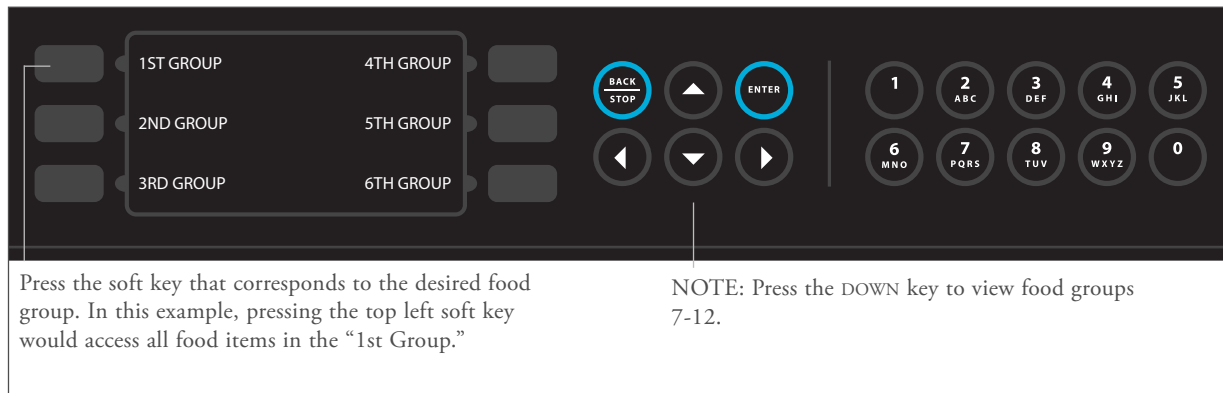

FIGURE 9: Selecting a Food Group

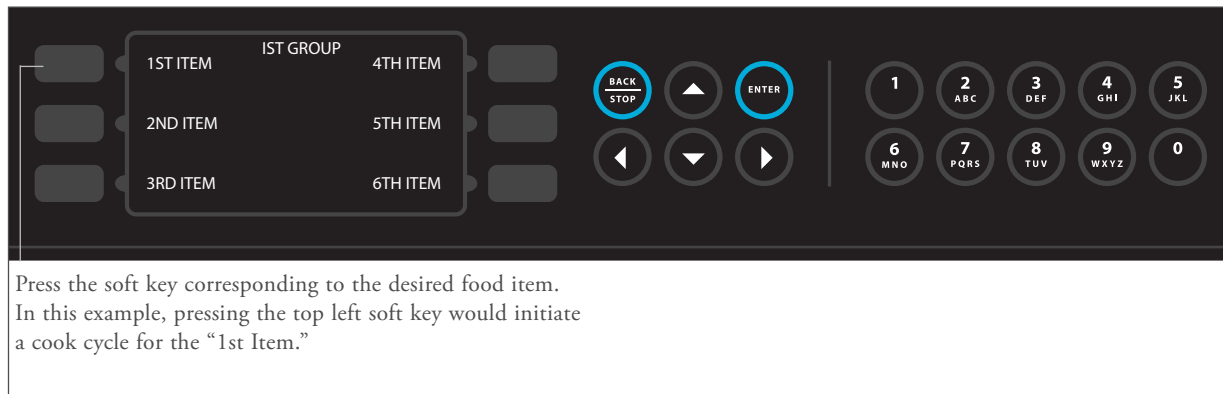

FIGURE 10: Selecting a Food Item

## Cooking Instructions

Each oven is pre-programmed with recipe settings and is ready to operate out of the box. For instructions on customizing these settings, see page 18.

To select a recipe and initiate a cook cycle:

1. Press the ON/OFF key to turn the oven on.  
The oven will start warming up.
  2. Once the oven reaches its predetermined cook temperature (typically 500°F or 260°C), it will beep and display “Ready to Cook.”
  3. Carefully place food item to be cooked in the cook cavity.
- ⚠ WARNING: Inside of oven is HOT! Insert food with caution.**
4. To select a food group, press the corresponding soft key (Figure 9).

NOTE: Press the DOWN key to view food groups 7–12.

5. Select the item to cook by pressing the corresponding soft key (Figure 10).
  6. The oven will begin cooking, unless the TIME screen is enabled (see page 14).
- NOTE: To immediately terminate a cook cycle, press the BACK/STOP key.
7. When cooking is complete, the oven will beep and display “Please Remove Food from Oven.”
- ⚠ WARNING: Inside of oven is HOT! Remove food with caution.**
8. Remove the food. The oven will return to the food group selection screen unless the DONE screen is enabled (see page 14).

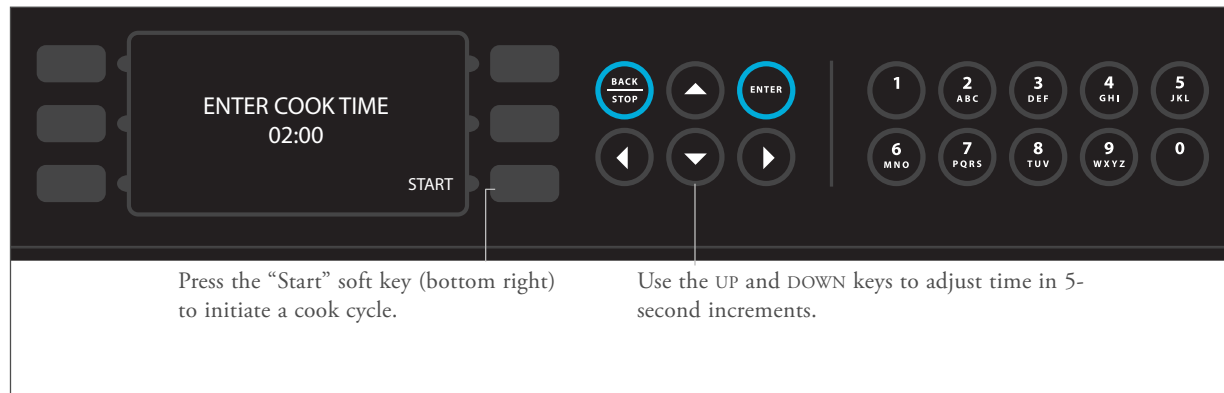

FIGURE 11: Time Screen

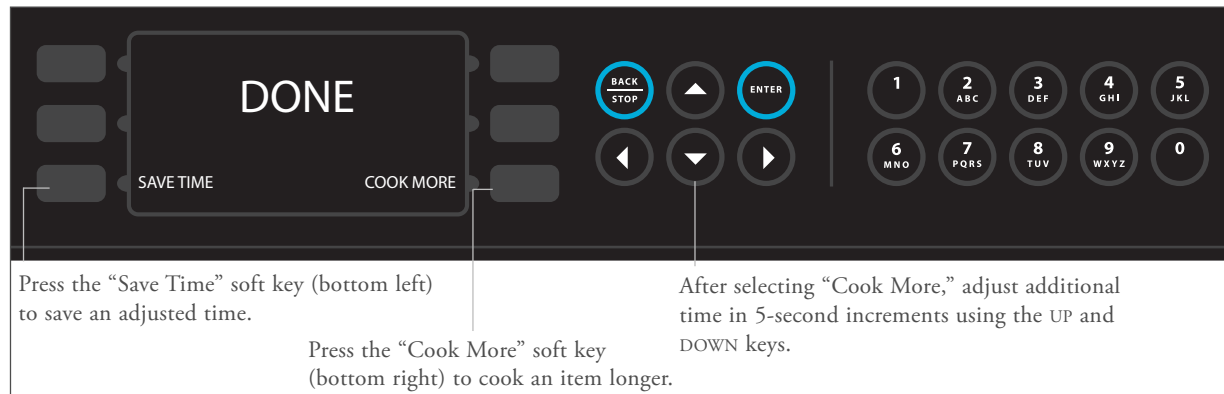

FIGURE 12: Done Screen

## Additional Cooking Options

### Time Screen

Reference Figure 11. If the TIME screen is enabled, before initiating a cook cycle the operator will be given the option to adjust the cook time in 5-second increments.

To learn about enabling and disabling the TIME screen, see page 16.

### Done Screen

Reference Figure 12. If the DONE screen is enabled, the operator is given two choices upon opening the oven door at the end of a cook cycle:

1. Save Time – save an adjusted cook time (only if the TIME screen is also enabled).
2. Cook More – cook an item longer after it reaches the end of its cook cycle.

When an item is cooked longer, the oven cooks it to the specifications of the final event in the initial cook cycle. To learn about events of a recipe, see *Modifying Recipes* (pages 18-21).

To learn about enabling and disabling the DONE screen, see page 17.

## Options Menu

Use the OPTIONS menu to:

- Enable/disable the EDIT menu
- Erase the RECIPE MENU
- Enable/disable the WRITE CARD function
- Enable/disable the TIME screen
- Enable/disable the DONE screen
- Enable/disable DEMONSTRATION mode

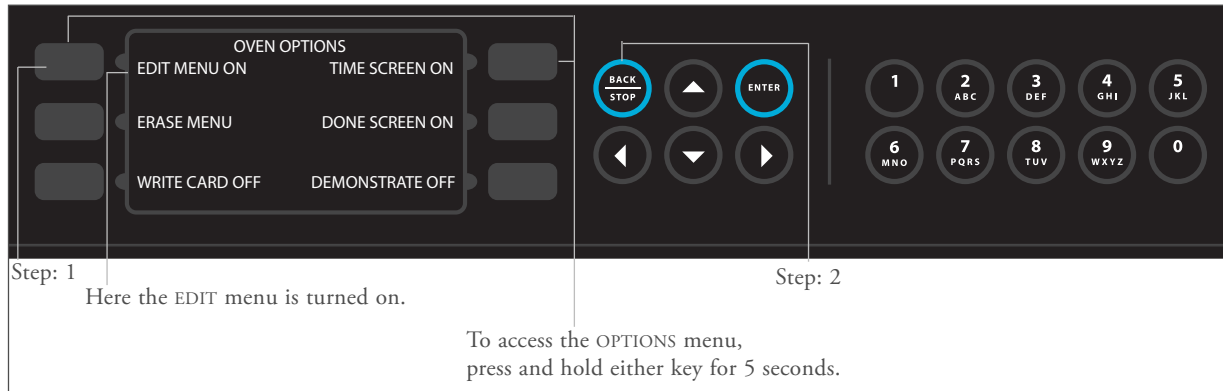

FIGURE 13: Enabling/Disabling the Edit Menu

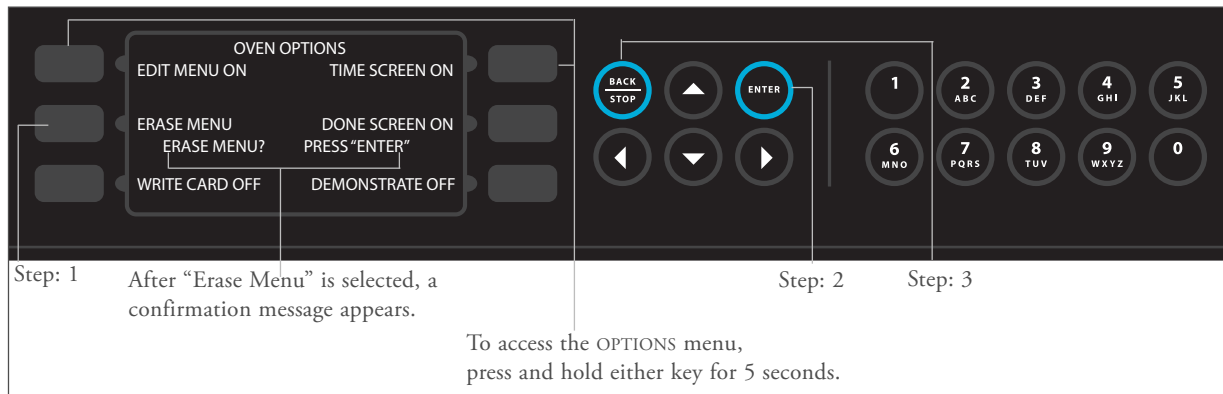

FIGURE 14: Erasing the Menu

To access the **OPTIONS** menu:

1. Ensure the oven is cooling down or off.
2. Press and hold either the top left or top right soft key for 5 seconds.

### Enabling/Disabling the Edit Menu

Reference Figure 13. Enabling the **EDIT** menu allows operators to modify the cook cavity temperature, group/item names, and recipe settings. Disabling the **EDIT** menu prevents operators from accessing these options. By default, the **EDIT** menu is enabled.

To enable/disable the **EDIT** menu:

1. From the **OPTIONS** menu, press the “Edit Menu” soft key (top left) to turn the **EDIT** menu on/off.
2. Press the **BACK/STOP** key to exit.

### Erasing the Recipe Menu

Reference Figure 14. Erasing the **RECIPE MENU** will permanently delete currently-stored recipes and recipe settings, and is generally not recommended.

To erase the **RECIPE MENU**:

1. From the **OPTIONS** menu, press the “Erase Menu” soft key (middle left).
2. Press the **ENTER** key to confirm or the **BACK/STOP** key to cancel.
3. Press the **BACK/STOP** key to exit.

**NOTE:** Erasing the recipe menu is not required when uploading new settings from a smart card (page 20).

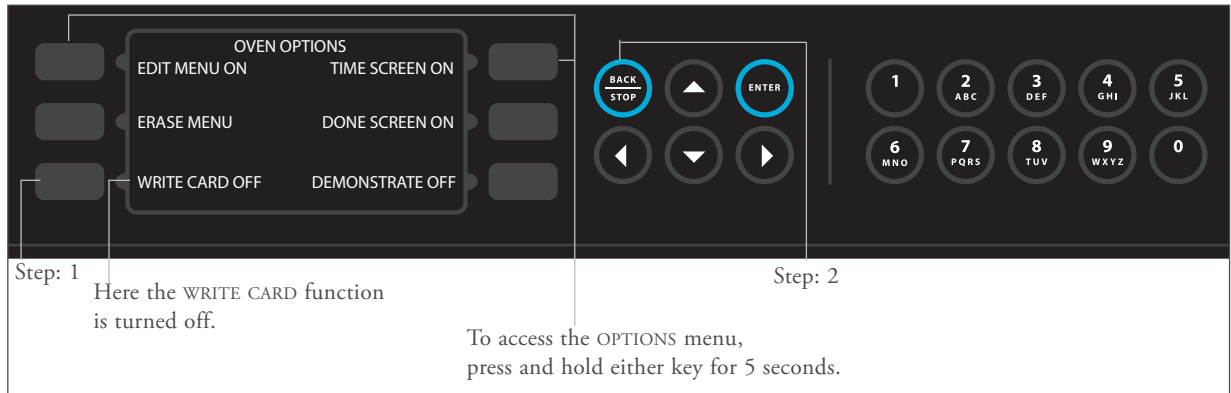

FIGURE 15: Enabling/Disabling the Write Card Function

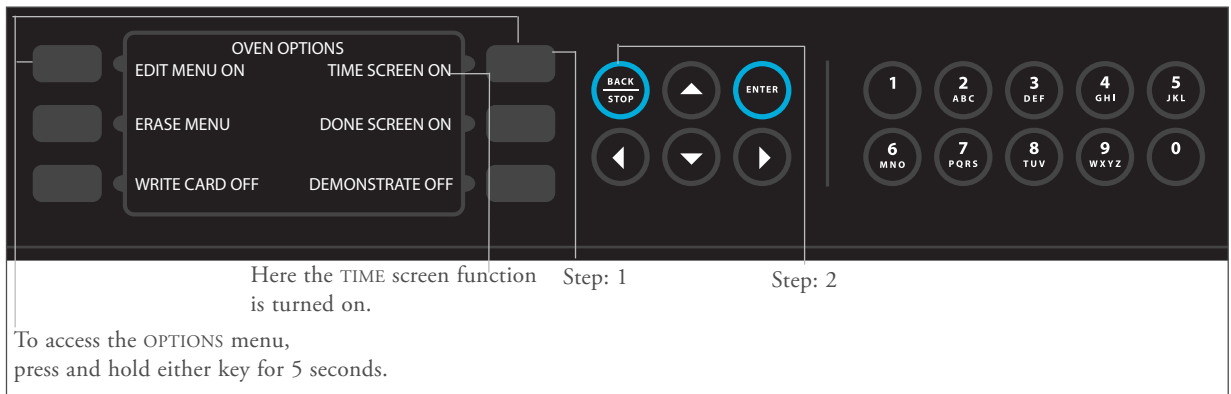

FIGURE 16: Enabling/Disabling the Time Screen

**Enabling/Disabling the Write Card Function**

Reference Figure 15. Enabling the WRITE CARD function allows the operator to save recipes from the oven to a smart card. Disabling the WRITE CARD function prevents operators from doing so. By default, the WRITE CARD function is disabled.

To enable/disable the WRITE CARD function:

1. From the OPTIONS menu, press the “Write Card” soft key (bottom left) to turn the WRITE CARD function on or off.
2. Press the BACK/STOP key to exit.

**Enabling/Disabling the Time Screen**

Reference Figure 16. Enabling the TIME screen allows the operator to adjust the total cook time before initiating a cook cycle. Disabling it helps ensure originally-programmed cook times remain unaltered.

To enable/disable the TIME screen:

1. From the OPTIONS menu, press the “Time Screen” soft key (top right) to turn the TIME screen function on or off.
2. Press the BACK/STOP key to exit.

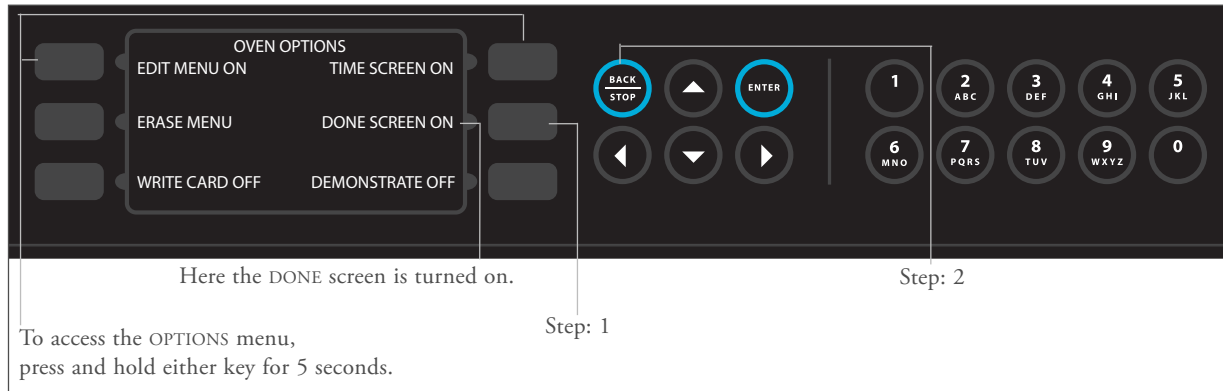

FIGURE 17: Enabling/Disabling the Done Screen

### Enabling/Disabling Done Screen

Reference Figure 17. Enabling the DONE screen allows the operator to:

- Save an adjusted cook time
- Cook an item longer after it reaches the end of its cook cycle

Disabling it helps ensure all originally-programmed cook times remain unaltered. By default, the DONE screen is enabled.

To enable/disable the DONE screen:

1. From the OPTIONS menu, press the “Done Screen” soft key (middle right) to turn the DONE screen on or off.
2. Press the BACK/STOP key to exit.

### Demonstration Mode

When enabled, demonstration mode will prevent the oven from heating. This mode should remain off unless otherwise instructed by TurboChef.

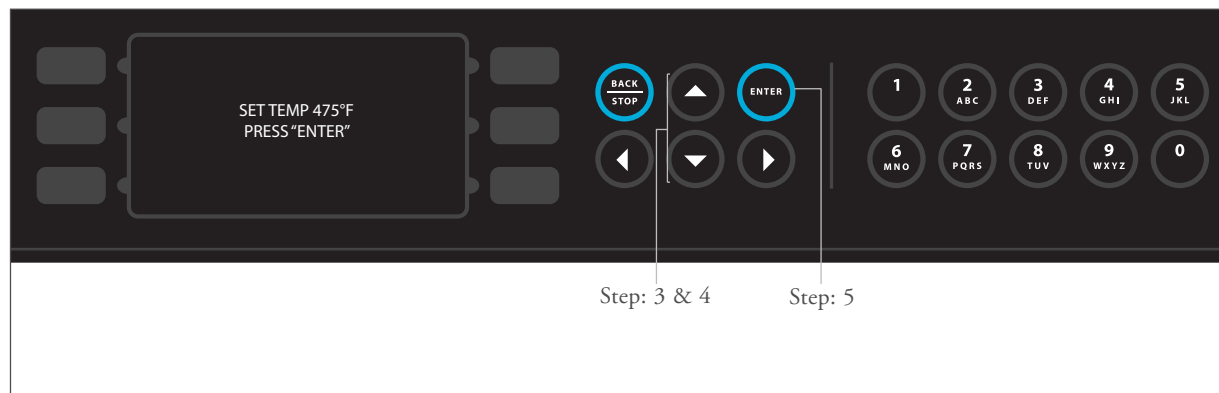

FIGURE 18: Adjusting the Cook Cavity Temperature

## Programming Recipes

Programming options include:

- Adjusting the temperature set point
- Modifying recipes
- Loading a menu from a smart card
- Saving a menu to a smart card
- Checking the recipe counter

For accessibility to programming options, the oven must be either cooling down or off.

### Adjusting the Cook Cavity Temperature

Reference Figure 18.

1. Ensure the oven is either cooling down or off.
2. Verify the EDIT menu is enabled (for instructions, see page 15).
3. Press and hold the UP key for 1 second.
4. Adjust the cook cavity temperature in 25°F (15°C) increments using the UP and DOWN keys.
5. Press ENTER to confirm the change and proceed to editing individual recipes, or press the BACK/STOP key to cancel.

### Modifying Recipes (Figures 19-21)

To modify a food item:

1. Ensure the oven is either cooling down or off.
2. Verify the EDIT menu is enabled (for instructions, see page 15).
3. Press and hold the UP key for 1 second.
4. Adjust the cook cavity temperature in 25°F (15°C) increments using the UP and DOWN keys.
5. Press ENTER to confirm the change and proceed to editing individual recipes.
6. Select the food group that contains the item to be modified (Figure 19).
7. Select the food item to be modified (Figure 20).
8. From FOOD ITEM screen (Figure 21):
  - a. Press the LEFT or RIGHT key to move from one field to another. The field selected to be modified will be bracketed.
  - b. Press the top-left and top-right soft keys to move from one character to another.
  - c. Change the food group and item names using the number keys or the UP and DOWN keys.

NOTE: Pressing the UP and DOWN keys will clear the field of its current content unless you first press either the top-left or top-right soft key.

- d. Set the cook time by pressing the UP and DOWN keys (5-second increments).
- e. Turn rack oscillation on or off by pressing the UP or DOWN key.
- f. Enter cook time percentage per event (total must equal 100%) using the number keys.
- g. Enter % air per event using the number keypad (rounds to nearest 5, with minimum setting of 10%).
9. To test settings before saving, press the bottom-left soft key. The oven will initiate a cook cycle to the new settings specifications.
10. To save settings, press ENTER. “Settings Saved” will be displayed.
11. Press the BACK/STOP key to exit the menu (doing so before saving settings will discard changes).

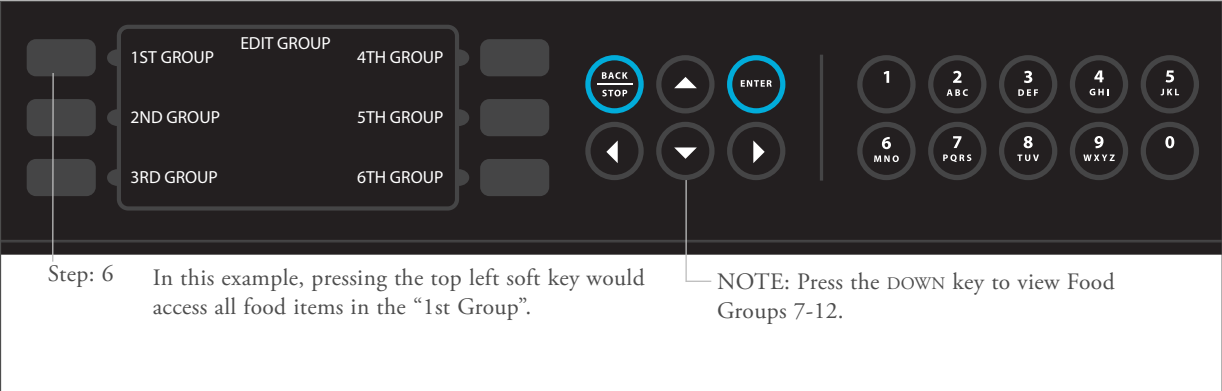

FIGURE 19: Modifying Recipes – Step 6

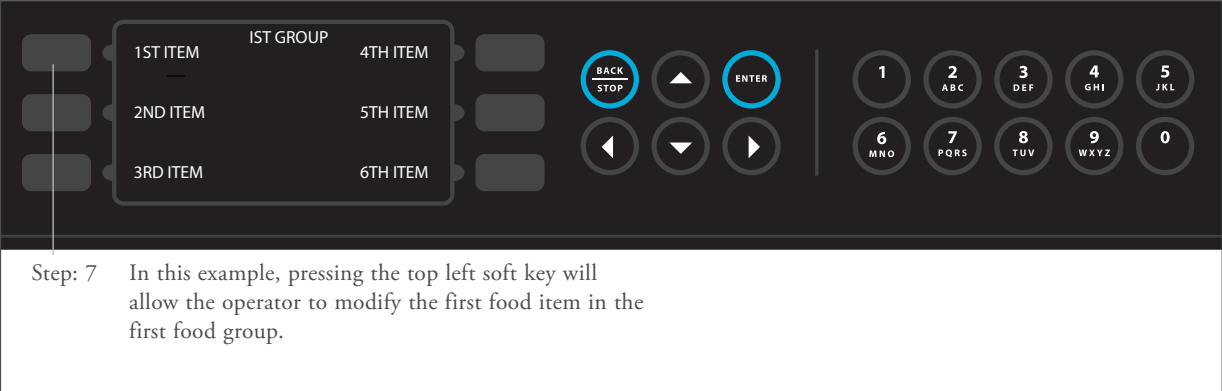

FIGURE 20: Modifying Recipes – Step 7

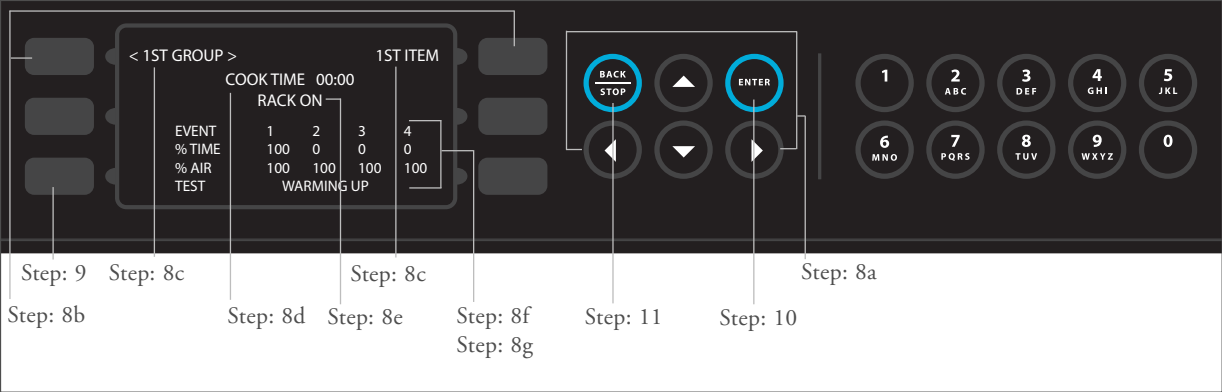

FIGURE 21: Modifying Recipes – Steps 8-11

### Ordering a Smart Card

To order a Smart Card, call 1-800-90TURBO, +1 214-379-6000, or your Authorized Distributor.

### Loading Menu from Smart Card

**⚠ CAUTION:** Loading a menu from a smart card will overwrite all existing recipes programmed into the oven.

To load a menu from a smart card:

1. Ensure the oven is either cooling down or off.
2. Insert the smart card into the smart card reader. Orient the card as shown in Figure 22.
3. Press the bottom-left soft key.
4. Press the middle-left soft key to “Load Menu from Card” (Figure 23).
5. Press ENTER to confirm or BACK/STOP to cancel.

After approximately 5 seconds, screen will display that menu has loaded from card.

### Saving Menu to Smart Card

**⚠ CAUTION:** Saving a menu to a smart card will overwrite all existing recipes programmed into the smart card.

To save a menu to a smart card:

1. Ensure the oven is either cooling down or off.
2. Verify the WRITE CARD function is enabled (for instructions, see page 16).
3. Insert the smart card into the smart card reader. Orient the card as shown in Figure 22.
4. Press the bottom-left soft key.
5. Press the top-left soft key to “Save Menu to Card” (Figure 24).
6. Press ENTER to confirm or BACK/STOP to cancel.

### Checking Recipe Counter

Reference Figure 25. To view how many times each recipe (food item) has been cooked:

1. Press and hold the middle-left or middle-right soft key for 3 seconds.
2. The screen will display food items in the first food group. To view other food groups, use the UP and DOWN keys.
3. Press the BACK/STOP to exit the menu.

**NOTE:** To erase counters, press ENTER when viewing the totals.

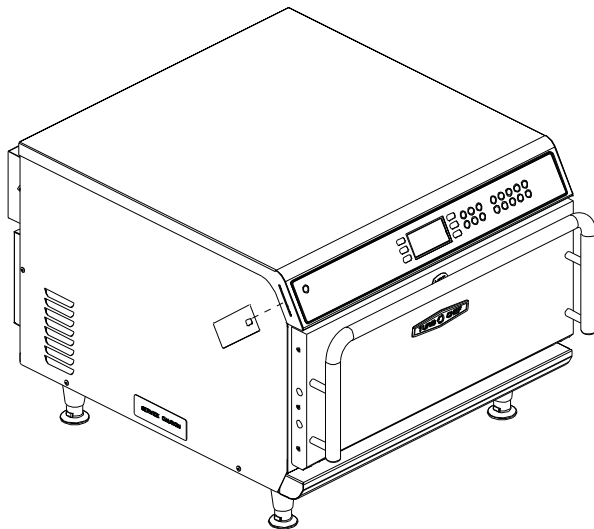

FIGURE 22: Inserting Smart Card into Reader



FIGURE 23: Loading from Smart Card



FIGURE 24: Saving to Smart Card

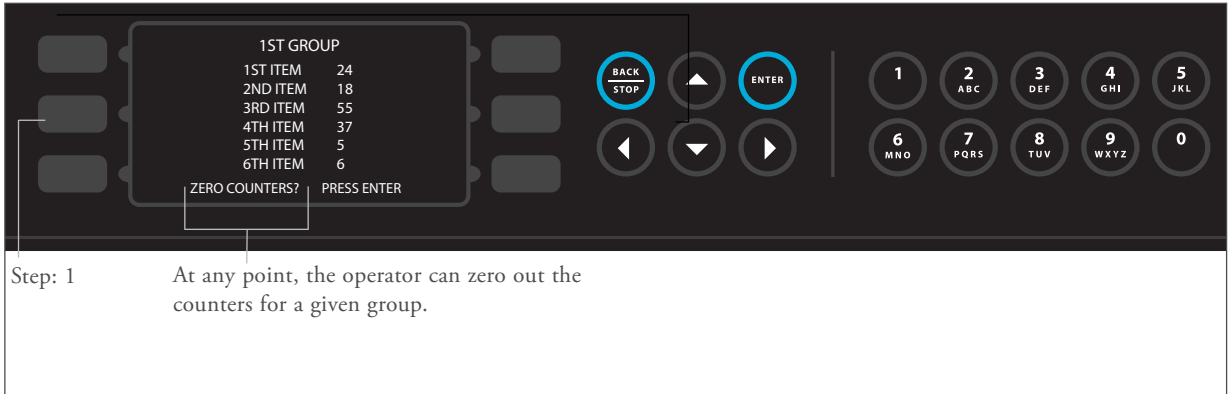

FIGURE 25: Checking the Recipe Counter

# Troubleshooting Tips

To help ensure troubleshooting accuracy and minimize the time your oven is down, please follow the steps below regarding:

- Recording the serial number
- Recording error messages
- Checking the fault log
- Common issues and solutions

## Recording the Serial Number

1. Ensure the oven is either cooling down or off.
2. Press and hold the RIGHT key for 1 second.
3. Press the DOWN key to view next menu screen.
4. Press the “S/N” soft key (bottom right).
5. Write down the serial number and have it ready when speaking with Customer Support.
6. Press the BACK/STOP key to exit the menu.

## Recording Error Messages

If the screen displays a message when a problem occurs, write down the message and have it ready to reference when speaking with Customer Service.

## Checking the Fault Log

Before calling Customer Support, write down any faults the oven has logged. To check the fault log:

1. Ensure the oven is either cooling down or off.
2. Press and hold the RIGHT key for 1 second.
3. Press the FAULTS soft key (middle left).
4. Write down the faults with a count higher than zero.
5. Press the BACK/STOP key to exit the menu.

## Common Issues and Solutions



**WARNING:** When troubleshooting issues with the oven, follow all safety instructions (page i). Turn off the oven before troubleshooting any areas that when active may cause personal injury (e.g., cook cavity, electrical components, etc.).

The table on page 23 lists some common issues and possible solutions. If additional help is required, contact Customer Service at 1-800-90TURBO, +1 214-379-6000, or your Authorized Distributor.

ISSUE	POSSIBLE SOLUTION(S)
Oven is not receiving power.	<ul style="list-style-type: none"> <li>□ Ensure the oven is plugged in.</li> <li>□ Verify wall circuit breaker is on.</li> <li>□ Reset breaker and then power up the oven.</li> </ul>
Oven is not warming up properly or Fault Code: F8 Fault.	<ul style="list-style-type: none"> <li>□ Follow the deep cleaning procedures (pages 10-11) to remove debris that may potentially be preventing air circulation.</li> <li>□ Reset the high-limit thermostat (press the red button on the back of the oven).</li> <li>□ Ensure the door is closed.</li> </ul>
Oven is not cooking properly	<ul style="list-style-type: none"> <li>□ Follow the deep cleaning procedures (pages 10-11) to remove debris that may potentially be preventing air circulation.</li> <li>□ Ensure correct food group and/or food item is selected for the product.</li> <li>□ Ensure product is cooked from the correct starting state (e.g., fresh, frozen, etc.).</li> </ul>
Fault Code – F2: Cook Temperature Low	<ul style="list-style-type: none"> <li>□ Ensure the door is closed.</li> <li>□ Reset the high-limit thermostat (press the red button on the back of the oven).</li> <li>□ Repeat warm-up and allow the oven to idle for five (5) minutes.</li> <li>□ Reduce volume of frozen product.</li> </ul>
Fault Code – F6: EC Temp	<ul style="list-style-type: none"> <li>□ Ensure atmosphere temperature around the oven is moderate (i.e., less than 120°F (49°C)).</li> <li>□ Ensure nearby appliances or fixtures are not obstructing airflow into the back cooling fans.</li> <li>□ Ensure cooling fans on the back of the oven are not clogged with debris.</li> </ul>

For additional assistance or if the oven is experiencing a problem not listed above, call Customer Service at 1-800-90TURBO, +1 214-379-6000, or your Authorized Distributor.

# North America Limited Warranty

## TurboChef High h Batch Oven - North America

The TurboChef High h Batch 2 Oven limited warranty outlined below is activated upon shipment of your oven. Should you require additional assistance after reviewing the limited warranty outlined below, please call TurboChef Customer Service at 800.90TURBO or +1 214-379-6000.

### LIMITED WARRANTY

TurboChef Technologies, Inc. (“TurboChef”) warrants to you, the purchaser, that under normal use, the TurboChef High h Batch 2 Oven you have purchased (the “Equipment”) will be free from defects in material and workmanship during the Warranty Period, subject to the terms and conditions set forth herein. The “Warranty Period” is twelve (12) months from the date the Equipment is shipped from TurboChef’s factory or distribution center. This limited warranty is conditioned upon you promptly notifying TurboChef of any claims, as provided in the paragraph entitled “Warranty Claims” below, and providing TurboChef with all data and information requested by TurboChef or its service agents in connection with such claims as well as all necessary access to your premises and the Equipment. This limited warranty is made only to the initial purchaser of the Equipment from TurboChef or its authorized dealer; it is not assignable to subsequent purchasers unless TurboChef consents to such assignment in writing.

### DISCLAIMER OF WARRANTIES

Except as provided in the limited warranty above, the Equipment is provided “as-is.” TurboChef disclaims all other warranties, express, statutory or implied, including without limitation the implied warranties of title, non-infringement, merchantability and fitness for a particular purpose. TurboChef does not warrant that the Equipment will meet your specifications or needs. You acknowledge that you are solely responsible for the selection of the Equipment and determining the suitability of the Equipment for your needs.

### WARRANTY EXCLUSIONS

**Improper Installation, Operation or Maintenance:** Equipment that is not installed, operated and maintained in accordance with TurboChef’s High h Batch 2 Oven owner’s manual (as may be updated by TurboChef from time to time, the “Manual”), a copy of which is provided to you with the Equipment or otherwise will be provided to you upon request, is excluded from this limited warranty. This limited warranty does not apply to damage or failure which results, in TurboChef’s or its service agent’s sole opinion, from failure to provide a suitable installation and operating environment (including power and HVAC) and facilities as prescribed by the Manual, misuse, abuse, accident, neglect, power failure, power surges (over or under voltage), or to damage or failure from flood, fire, lightning, or other natural or man-made disasters, or other Acts of God, or to Equipment that has missing or altered serial numbers.

**Modifications and Repair:** Equipment that has been modified or altered by persons other than TurboChef or its service agents, or Equipment that has had non-approved devices or connection items attached thereto, is excluded from coverage under this limited warranty. Repair of the Equipment by anyone other than TurboChef or its authorized service agents will void all warranties on the Equipment.

**Accessories:** Accessories and parts (collectively “Accessories”) that are consumed in the normal course of Equipment operation or maintenance are excluded from this limited warranty. Failure of or damage to Equipment or components from the use of non-approved cleaning chemicals, devices or processes is also excluded from this limited warranty.

**Outstanding Invoices:** If the full invoiced amount for Equipment purchased has not been paid within forty-five (45) days from the invoice date, then TurboChef will have no obligation to honor this or any other warranty on the Equipment until payment is received in full, and any accrued interest or other charges have been satisfied, at which time warranty coverage will be reinstated, but the Warranty Period will not be extended.

#### **WARRANTY SERVICE; EXCLUSIVE REMEDY**

TurboChef will be solely responsible for determining whether or not the Equipment or any component thereof is defective. Defective components covered by this limited warranty will be repaired or replaced at TurboChef’s option without charge to you and such repaired or replacement components will be covered by this limited warranty for the balance of the Warranty Period. Parts used in the repair of defective components and replacement components may be new, recovered or rebuilt. At its sole option, TurboChef may decide to replace defective Equipment covered by this limited warranty with new, recovered or rebuilt Equipment of equal or greater capability, and such Equipment will be covered by this limited warranty for the balance of the Warranty Period. Defective Equipment and components will become the property of TurboChef. This paragraph states TurboChef’s sole and exclusive obligation and liability and your sole and exclusive remedy under this limited warranty. TurboChef shall not be responsible for a failure to provide warranty services due to causes beyond TurboChef’s or its service agents’ control.

#### **WARRANTY CLAIMS**

Claims under this limited warranty must be reported to TurboChef during our normal working hours at the following number: 1-800-90TURBO, or such other reporting service as TurboChef may designate. Upon receipt of the claim and related information and preliminary verification that the claim is valid, TurboChef will promptly notify an authorized service agent to contact you and arrange for an on-site repair visit during the service agent’s normal working hours. Any costs incurred by TurboChef or its service agent associated with a service agent being refused or unable to gain access to the Equipment on your premises, or a claim not covered by this limited warranty, will be charged to you.

#### **CHARGES FOR NON-WARRANTY SERVICE**

In the event that repairs, replacement or service are provided by TurboChef’s service agents for work not covered by this limited warranty, prior to commencing such work or service, the service agent will obtain your permission to proceed and will invoice you directly for such work or service. You will pay the service agent directly according to the service agent’s normal scale of charges and business terms.

## DISCLAIMER OF DAMAGES

TurboChef disclaims all incidental, special and consequential damages, including but not limited to loss of use, lost revenue or profits, or substitute use, suffered by you or any third party, whether arising in contract, tort (including negligence), or otherwise, resulting from any breach by TurboChef or its service agents of this limited warranty, or resulting from the manufacture, use, or defects, of or in the Equipment, even if TurboChef was apprised of the possibility of such damages.

## CUSTOMER INDEMNITY

You agree to indemnify, defend and hold TurboChef harmless from all third party claims, demands, judgments, fees and costs directly or indirectly arising out of or related to your use of the Equipment. You further agree to indemnify and hold TurboChef harmless from any incidental, consequential or special damages suffered by you, including lost revenue or profits, loss of use, or substitute use, during periods of Equipment failure or loss of use.

## TERRITORY

This limited warranty is valid in the United States of America, Canada, and Puerto Rico.

## GOVERNING LAW, ENTIRE WARRANTY

This limited warranty shall be governed and construed in accordance with the laws of the State of Georgia, USA (except with respect to its provisions regarding conflicts of laws). The limited warranty described herein is the complete and only warranty for Equipment and supersedes all prior oral or written agreements and understandings that may have existed between us relating to Equipment warranties. The terms of this limited warranty may not be altered, amended or modified except by a signed writing from TurboChef. Any purported alteration, amendment or modification by a service agent or anyone else will not be enforceable against TurboChef.

## Warranty Parts Return

TurboChef Technologies, Inc.  
Attention: Warranty Parts  
2801 Trade Center Drive, Suite 110  
Carrollton, Texas 75007

# International Limited Warranty

## TurboChef High h Batch 2 Oven - International

This limited warranty shall apply to the sales of all TurboChef High h Batch 2 ovens (the “Equipment”) manufactured by TurboChef Technologies, Inc. (“TurboChef”), and sold to purchasers outside of the United States, Canada, Puerto Rico, Central and South America by an Authorized Distributor of TurboChef International (the “Authorized Distributor”).

### Limited Warranty

You, the purchaser (“You”) have entered into a sales contract with the Authorized Distributor for the purchase of the Equipment. This limited warranty is made to you by the Authorized Distributor from whom you purchased the Equipment with the support of TurboChef. Subject to the limitations stated below, the Authorized Distributor warrants to You that the quantity and specification of the Equipment delivered to You shall be as set out in the Authorized Distributor’s acceptance of your order and that the Equipment will be free from any material defects in the product and workmanship for twelve (12) months from the date of installation (the “Warranty Period”), subject to the terms and conditions set forth herein.

### DISCLAIMER

You acknowledge that You are solely responsible for the selection of the Equipment and determining the suitability of the Equipment for Your needs. All other warranties, conditions or terms relating to fitness for purpose, quality or condition of the Equipment, whether expressed or implied by statute or common law or otherwise are excluded to the fullest extent permitted by law.

### THE TURBOCHEF GLOBAL WARRANTY SYSTEM

This limited warranty commences upon delivery of the Equipment to Your premises. The Authorized Distributor will inspect and install the Equipment at Your premises in accordance with TurboChef’s instructions and will record the serial number of the Equipment, Your contact details, the date and location of installation and the results of the Authorized Distributor’s inspection. This information will be entered by the Authorized Distributor into the TurboChef global warranty system and will be used by TurboChef, the Authorized Distributor and its authorized service agents for the provision of the warranty service.

### WARRANTY SERVICE

During the Warranty Period, any materially defective Equipment will be repaired or replaced free of charge at TurboChef’s option provided that:

1. You notify the Authorized Distributor from whom You purchased the Equipment and/or TurboChef as soon as reasonably possible after discovery of a defect and in accordance with the warranty claims procedure set out below;
2. You provide the Authorized Distributor from whom You purchased the Equipment and/or TurboChef with all data and information reasonably requested by TurboChef, the Authorized Distributor or its authorized service agents in connection with Your warranty claim;

3. You make the Equipment available to TurboChef, the Authorized Distributor or its authorized service agents;
4. The Equipment has been installed by an Authorized Distributor and you have provided all necessary information for the Authorized Distributor to register the Equipment in the TurboChef global warranty system;
5. The Equipment has been operated and maintained by You in accordance with TurboChef's "Owner's Manual" provided with the Equipment (and as updated by TurboChef);
6. You have not used any non-approved devices, accessories, consumables or parts in conjunction with the Equipment; and
7. Repairs, modifications or alterations have not been attempted other than by TurboChef, an Authorized Distributor or its authorized service agent.

Neither TurboChef nor the Authorized Distributor assumes any liability for damage caused by Your failure to provide a suitable installation and operating environment (including power and HVAC) or facilities as prescribed by the Manual, misuse or abuse or by accident, neglect, power failure or power surges (over or under voltage) howsoever arising.

At its sole option, TurboChef may replace defective Equipment or components with new, recovered or rebuilt Equipment of equal or greater capability, and such Equipment or components will be warranted by the Authorized Distributor for the balance of the Warranty Period. Replaced defective Equipment or components will become the property of TurboChef.

**Warranty Claims:** Any warranty claim must be made directly in writing either to the Authorized Distributor from whom You purchased the Equipment or to TurboChef at the following address:

TurboChef Technologies, Inc.  
4240 International Parkway, Suite 105  
Carrollton, Texas 75007  
Phone: +1 214-379-6000  
Fax: +1 214-379-6073

The claim must include the serial number of the Equipment and be received by TurboChef on or before the last day of the Warranty Period. Upon receipt of Your claim, TurboChef will promptly notify an Authorized Distributor or an authorized service agent to contact You, to verify Your claim and, if necessary, to arrange for an on-site repair visit during normal working hours.

**Consumables and Parts Used with The Equipment:** Neither TurboChef nor the Authorized Distributor assumes any liability for consumables and parts that are used in the normal course of Equipment operation or for failure of or damage to Equipment or components from the use of non-approved cleaning chemicals, devices or processes.

**Charges for Service Not Covered by Limited Warranty:** In the event that You request and receive repairs, replacement or service not covered by this limited warranty, You will be invoiced and must pay the Authorized Distributor or authorized service agent directly according to its normal scale of charges and business terms.

**Product Liability:** Neither TurboChef nor the Authorized Distributor assumes any liability for any incidental, special or consequential damages, including but not limited to loss of use, lost revenue or profits, or substitute use suffered by You or any third party, whether arising in contract, tort (including negligence), or otherwise resulting from any breach by TurboChef or the Authorized Distributor of the limited warranty provided herein.

**Exclusive Remedy:** This limited warranty states the Authorized Distributors and TurboChef's sole and exclusive obligation and liability and your sole and exclusive remedy under this limited warranty.

**Third Party Rights:** The UK Contract (Rights of Third Parties) Act 1999 is excluded from applying to this limited warranty and nothing herein confers or purports to confer on any third party any benefit or any right to enforce any term of this limited warranty.

**Severability:** If any item or provision contained in this limited warranty or any part of them ("an offending provision") is declared to be or becomes unenforceable, invalid or illegal for any reason whatsoever in any jurisdiction, the other terms and provisions of this limited warranty shall remain in full force and effect in that jurisdiction as if it had been executed without the offending provision appearing in it and the entire limited warranty shall remain in full force and effect in all other jurisdictions.

**Governing Law, Entire, Agreement:** This limited warranty shall be governed by and construed according to English law. The application of the United Nations Convention on International Sale of Goods to this limited warranty is expressly excluded. This limited warranty may not be altered, amended or modified by the Authorized Distributor or its service agent, and no representation, alteration, amendment or modification by TurboChef shall be valid unless in a signed form from TurboChef.

### **Warranty Parts Return**

TurboChef Technologies, Inc.  
Attention: Warranty Parts  
2801 Trade Center Drive, Suite 110  
Carrollton, Texas 75007

*For service or information:*

WITHIN NORTH AMERICA CALL  
Customer Service *at* 1-800-90TURBO

OUTSIDE NORTH AMERICA CALL  
+1 214-379-6000 or Your Authorized Distributor



Part Number: HHB-8326/Revision B/August 2009  
© 2009 TurboChef Technologies, Inc.

*Global Operations*

4240 International Pkwy, Suite 105  
Carrollton, Texas 75007 USA  
+1 214.379.6000 PHONE  
+1 214.379.6073 FAX

*Customer Service:* 800.90TURBO

[www.turbochef.com](http://www.turbochef.com)