

Specification

Flexeserve Zone 2 Tier - Countertop

Flexeserve Zone delivers true hot-holding and flexible merchandising in one display using our unique, patented hot air technology.

Exclusive features

- ✳ Patented convection air system unlike any other heated display, for superior product quality, extended shelf life and industry-leading energy efficiency.
- ✳ Individually controlled zones with fully adjustable temperatures, from ambient to 194°F, to suit multiple products.
- ✳ Double glazed end panels and LED lighting to each shelf.
- ✳ Innovative range of accessories available to increase capacity, improve product visibility and provide operational efficiencies.
- ✳ Self-service heated display available in 3 widths.

Compelling benefits

- ✳ **True hot-holding** - products held at optimum quality for longer and served as they were intended. Zones are thermally isolated with no heat transfer. Hot-hold products with different requirements within one unit.
- ✳ **Extends food shelf-life** - quality and temperature are retained throughout the holding process, maximizing shelf life and minimizing waste.
- ✳ **Energy efficient** - industry-leading energy efficiency.
- ✳ **Large merchandising capacity** - utilize the three-dimensional volume of each zone by double stacking, without impacting temperature or quality.
- ✳ **Safety** - integrated over-temperature fail-safes, safe to touch surfaces and a flat shelf display for reduced risk of hot liquid spillages.
- ✳ **Flexeserve Solution** - our holistic approach includes menu development, cooking optimization, packaging support and operational advice, to help you increase sales and profit.

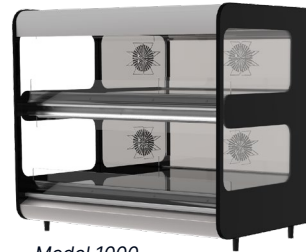

Model 1000,
Square



Model 600,
Square



Model 400,
Square



PRODUCT CAPACITY
Up to 36 soup
containers per shelf.



PATENTED TECHNOLOGY
Superior food quality and
energy efficiency.



PRODUCT CAPACITY
Up to 16 rotisserie
chickens per shelf.



Scan me to watch our **Holistic Approach** video.

Unique air recirculation technology

There's a lot of hot air being spoken by others. Flexeserve Zone uses patented, game changing convection technology to deliver true hot-holding. Hot air is continually circulated throughout the three-dimensional volume of each zone and creates a consistent and stable environment for your products.

This even distribution of air which can be set to the required temperature means food quality is maximized, unlike other heated displays that use outdated conduction which continue to cook food. In Flexeserve Zone, product integrity is maintained, resulting in performance and food quality unlike anything you have ever seen.

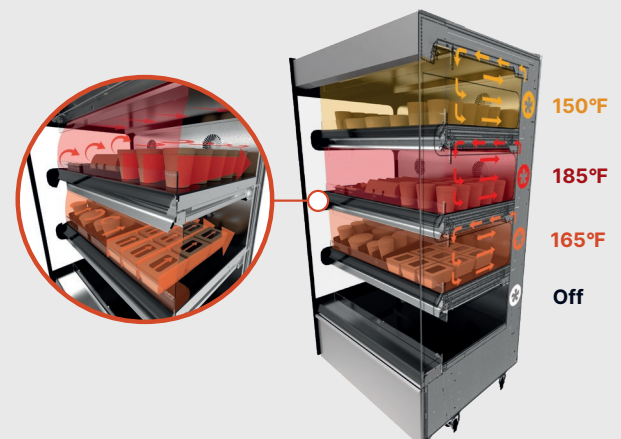

Specification

Flexeserve Zone 2 Tier - Countertop

Available in a range of widths and square profile as standard.

Standard features

- ✳ Stainless steel shelf edge.
- ✳ Standard ticket strip (2.09" height).
- ✳ Mirror polished back panel.
- ✳ Fan guards.
- ✳ Stainless steel canopy and valance - magnetic.
- ✳ LED lighting to each shelf.



Model 600, Square standard finishes

Customization options

Complement your brand and store environment with bespoke options for customization. You will find Brand Setting Guides at www.flexeserve.com

- ✳ Customized header board.
- ✳ End panel graphics / colors.
- ✳ Bespoke colors - canopy, valance, shelf edges.
- ✳ Custom ticket / POS holders.

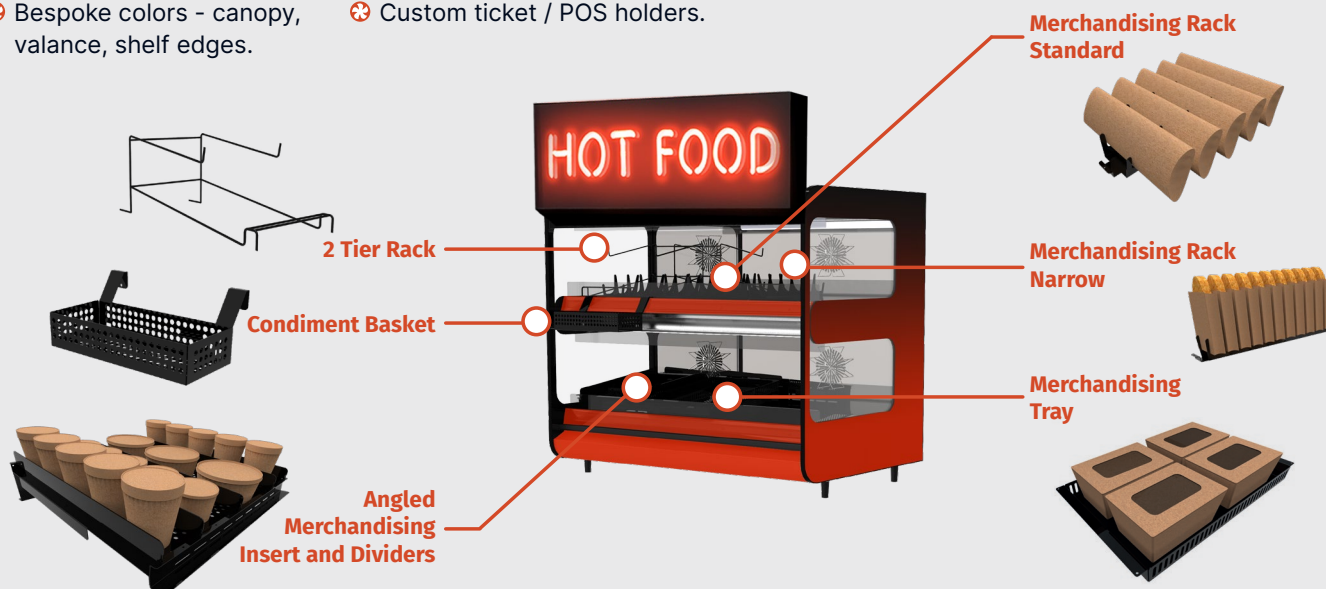

Accessories

Our innovative range of accessories increase visibility, capacity and operational efficiencies. They have been developed to be interchangeable and compatible with each other.



Scan me to view all accessories available for this model.

Product capacity*

PACKAGING CATEGORY	MODEL 400	MODEL 600	MODEL 1000
SOUP CONTAINER	12 Per Zone	20 Per Zone	36 Per Zone
WRAP / BURRITO	5 Per Zone**	10 Per Zone**	25 Per Zone**
BOWL (double stacked)	6 Per Zone	18 Per Zone	30 Per Zone

ACCESSORIES

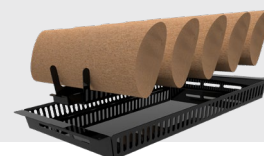

*Product capacity is an indication only, based on generic food packaging.

**Using Flexeserve Zone merchandising accessories - for complete range visit www.flexeserve.com/flexeserve-zone/accessories-and-customisation/

FLEXESERVE ZONE PATENTS

WO2014072693, WO2015044637, EP2916692, EP3048931, GB2509207, GB2518524, US2016213168, US2016235218, HK1193011, CA2925157, AU2014326399.

ACCREDITATIONS

Conforms to Standard UL 197 and NSF-4. Certified to CSA C22.2 No. 109.



Specification

2 Tier - Countertop Square



MODEL TYPE	400 SQUARE	600 SQUARE	1000 SQUARE
PRODUCT CODE	FXZNA40N2S-SF61	FXZNA60N2S-SF61	FXZNA10N2S-SF61
UNIT H / W / D inches	34.8 / 14 / 26	34.8 / 21.8 / 26	34.8 / 38.3 / 26
SHELF SIZE W / D inches / CAPACITY ft ³	12.8 / 16.3 / 0.9	20.7 / 16.3 / 1.5	37.2 / 16.3 / 2.63
UNIT WEIGHT lb	163	190	278
ELECTRICAL INFORMATION*			
POWER SUPPLY	Nema 6-15P Plug 208V 2 Wire + Ground (1Ph), 60Hz	Nema 6-15P Plug 208V 2 Wire + Ground (1Ph), 60Hz	Nema 6-20P Plug 208V 2 Wire + Ground (1Ph), 60Hz
TOTAL POWER PER ZONE	3.58A / 744W	3.58A / 744W	7.17A / 1492W
TOTAL POWER PER UNIT	7.15A / 1488W	7.15A / 1488W	14.35A / 2984W
ENERGY CONSUMPTION - HOURLY			
ONE ZONE / ALL ZONES	0.38 kWh / 0.76 kWh	0.38 kWh / 0.76 kWh	0.76 kWh / 1.52 kWh
SHIPPING CRATE			
SIZE H / W / D inches / WEIGHT lb**	43.8 / 27.5 / 30.3 / 33.1	43.8 / 27.5 / 30.3 / 33.1	43.8 / 42.1 / 30.3 / 44.1

* All models require a dedicated power supply.

** For accurate shipping weights including accessories and customization, contact info@flexeserve.com

UNIT VENTILATION - A 2" ventilation gap is required between the back of the unit and all solid surfaces. If located within housing or under a bulkhead, open ventilation above is required.

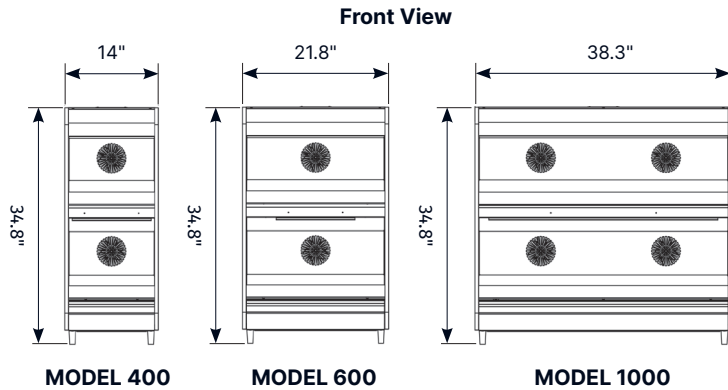
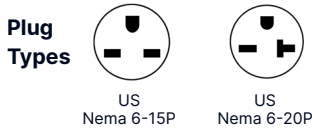

Profile View

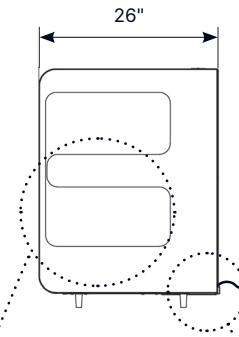

Interior Zone Dimensions

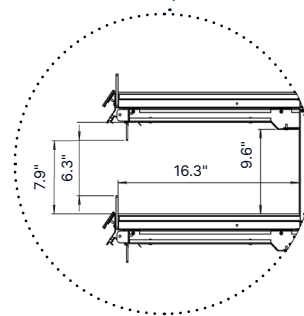

Foot Height & Power Cord Height / Length*

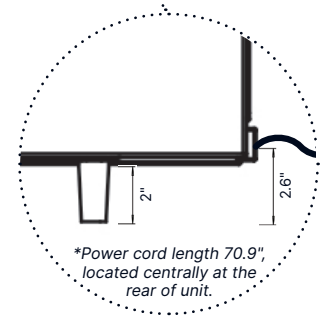

Shelf Footprint & Merchandising Volume*

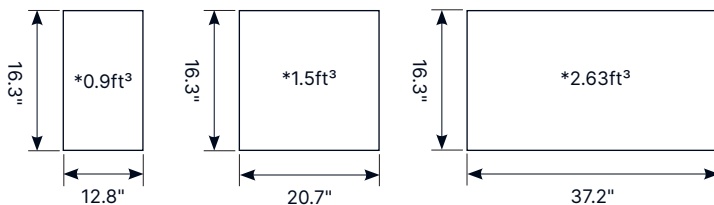

FLEXESERVE | © 2021 THE ALAN NUTTALL PARTNERSHIP LTD Reserve the right to alter information due to continued improvement in design. Flexeserve Zone is tested at conditions of +64.4°F.

flexeserveTM

For further information
info@flexeserve.com
flexeserve.com

Flexeserve Customer Support
 Call Toll-Free 833 955 8300
customer.support@flexeserve.com

