

# Food Prep. Tables

**SIDE MOUNTED CONDENSING UNIT (EP & EPP SERIES)**

Refrigerators



The Food Prep. Table (Side Mount) series features cold storage and working space for ingredients that need to be cut, sliced and prepared before use. It serves a variety of functions in the sandwich, burger, pizza, salad and dessert lines not only in prep-work but also in food assembly, as well as condiment, sauce and topping dispensary.

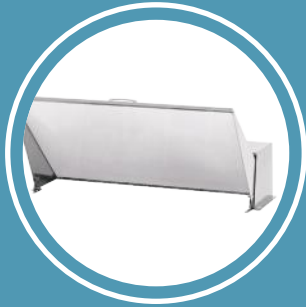

**Insulated Top Lid**  
Closes for cold storage.  
Props open when serving.



**Adjustable Top Pans**  
Detachable dividers accommodate  
varied top pan sizes.

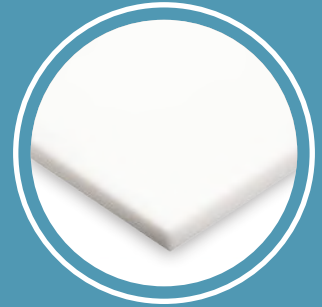

**Detachable Cutting Board**  
Removable for cleaning.  
Extendable for extra prep space.



**Blizzard R290**  
EPA/DOE approved, all-in-one,  
slide-out cooling cartridge.

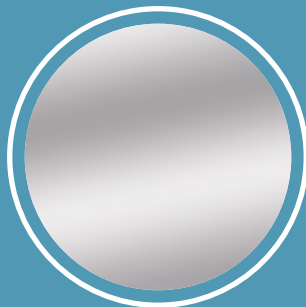

**All Stainless Steel**  
High quality finish with 2.5"  
thick thermal insulation.



**Ridge-Lined Gasket**  
Heavy-duty door gaskets  
snap out/in for easy cleaning.



**Optional Overshelf**  
Stainless steel double overshelf  
for additional storage.



**Other Features**  
Digital control, overheat  
alarm, ECM motors.



**More Features**  
LED lighting, vacuum relief,  
3" or 5" swivel casters.

# 24" Deep Side Mount Sandwich Prep Tables – EP Series

## Side Mounted Condensing Unit



EPR1-24



EPR2-24

### Cabinet Construction

- Heavy duty stainless steel interior / exterior with rounded corners for a hazard-free workspace.
- Open spaced interior with no walls between cabinet compartments.
- Vented stainless steel panel between top pan area and cabinet catches food debris.
- 16 gauge, high quality stainless steel worktop, lid and hood.
- Galvanized steel bottom and rear.
- 2.5" thick high density polyurethane insulation.
- Four 5" swivel casters with locks on front set.

### Refrigeration System

- Side mounted, self-contained and fully detachable Blizzard R290 condensing unit uses environmentally friendly, EPA-compliant R290 refrigerant with zero (0) Ozone Depletion Potential (ODP) and three (3) Global Warming Potential (GWP). Blizzard R290 is easily replaceable and requires no on-site brazing.
- Electronically commutated (ECM) fan motors achieve rapid cooling with less energy consumption.
- Full-length air duct ensures optimal cold air circulation.
- Time-initiated and temperature-terminated auto defrost cycle for seamless operation.
- Large capacity, corrosion-resistant condenser and evaporator coils.
- Self-maintaining, energy-efficient condensate drain pan requires no external drains or electric heaters.
- High performance, auto-reverse condenser fan motor supports compressor ventilation and condenser coil cleaning.
- Pressure relief devices allow rapid cabinet re-entry.
- Pre-wired and ready to plug, 115V/60Hz/1Ph, NEMA 5-15P.

### Lighting

- Energy efficient silicone coated and shatter-proof LED lighting provides bright, high color illumination with low heat output.

### Doors

- Heavy duty stainless steel interior / exterior.
- 2.5" thick high density polyurethane insulation.
- Frame heaters prevent exterior moisture build up.
- Self-closing with adjustable torsion system for a positive seal.
- Snap-in magnetic gasket for ease of cleaning.
- High strength, recessed handles.

### Preparation Area

- NSF certified polycarbonate 6" deep pans (see table for quantity).
- 1/2" thick, foam insulated lid keeps top pan area cold and prevents moisture build-up.
- 9" deep cutting board is removable for ease of cleaning.

### Shelving

- Two epoxy coated, steel wire shelves per section.
- Height adjustable stainless steel clips.

### Temperature Control

- Multi-function digital controller with easy to read LED display.
- Factory preset temperature, 35°F. Temp-set range from 33°F to 54°F.
- Audible overheat protection alarm for compressor and condenser coil.

### Options

- NSF certified stainless steel double overshef.
- Additional shelving.
- 3" swivel casters with locks.
- 3.5" – 6" height-adjustable and interchangeable legs.

↔ = Interior Dimensions   ← → = Exterior Dimensions

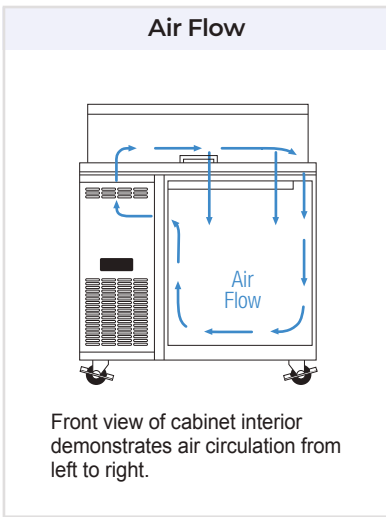

Equipped with 9 ft long NEMA 5-15P plug.

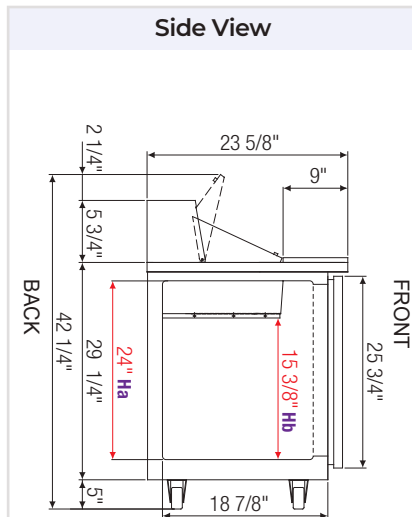

√ : Mounting space for oversheff.

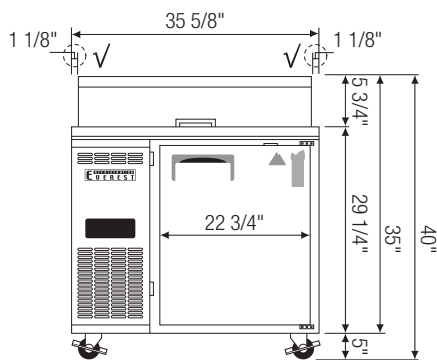
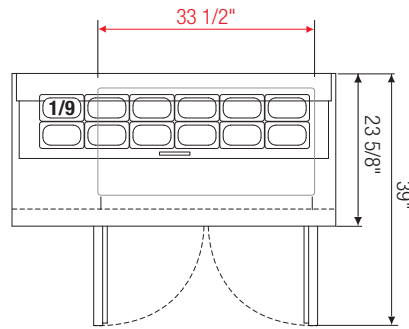
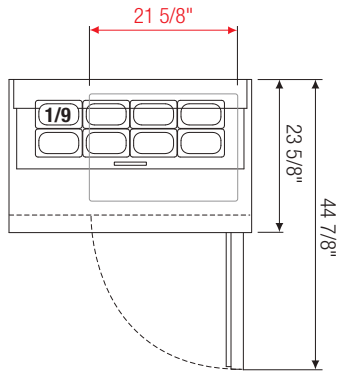

EPR1-24

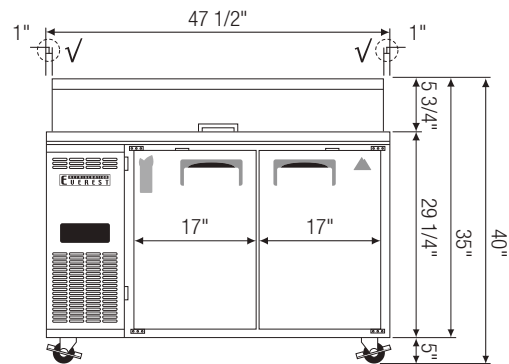

EPR2-24

Model	Ref/ Frz/ Dual	# of Doors	Capacity <sup>†</sup> (Cu. Ft.)	HP	# of Shelves	Refrigerant	# of Pans	Power (V-Hz-Ph)	Amps	Crated Weight (LBS)	Exterior Dimensions (Inches)		
											L	D	H*
EPR1-24	Ref	1	6	1/4+	2	R290	1/9 x 8	115-60-1	3.27	185	35 5/8	23 5/8	35
EPR2-24	Ref	2	9	1/4+	4	R290	1/9 x 12	115-60-1	3.48	229	47 1/2	23 5/8	35

\* Height does not include 5" for casters.

Ref = Refrigerator

Ha, Hb Interior Height

Specifications subject to change without notice.

Product dimensions are for general purposes and not absolute value. Product capacity (†) is calculated based on standard industry figures. Slight variations may exist. If dimensions and capacity are critical, please contact Everest Refrigeration.