

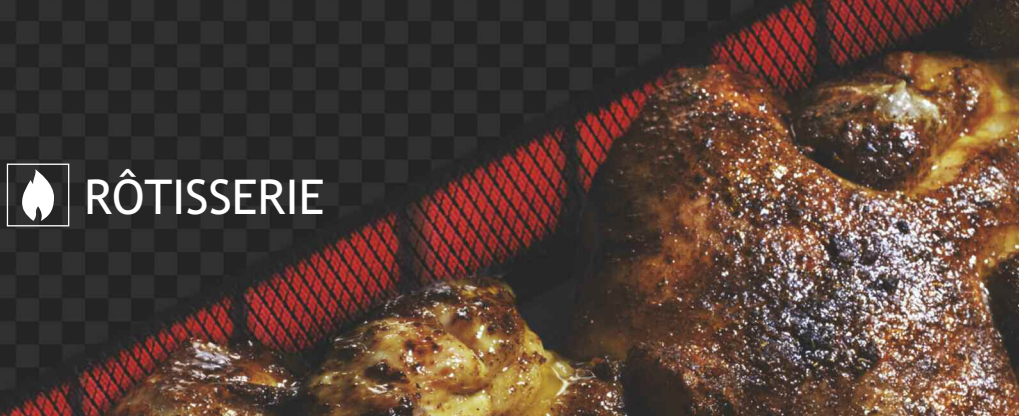

# FauxFlame™ FFS1425-4G



## DESIGN

The FauxFlame range of rotisseries has been designed with performance, practicality and mobility in mind. Light weight and compact FauxFlame is the ideal rotisserie for markets and food trucks and offers rapid production together with excellent cooking quality.

Conscious of the costs involved for our clients, the FauxFlame rotisserie has energy-saving infrared burners, patented by Rotisol, that enable the rapid roasting of a variety of products.

Shoppers are enticed by the attractive sight and appetizing smells of roasting poultry, beef, lamb, vegetables, and even fruit. An array of accessories allows for the rapid roasting of a wide variety of products.

## FEATURES

- Independent motor for each spit
- 4 Spatchcock Baskets with Bakelite handles
- Independent infrared gas burners with interchangeable ceramic bricks
- 2 K-glass doors (removable for transport)
- Bottom drip tray with drainage tap
- Optional lighting



FFS1425-4G-SSP  
Black Porcelain Enamel & Chrome  
shown on optional stand

## TECHNICAL DETAILS

Overview of some of the standard features.

	<p>Replaceable ceramic bricks for significant financial savings</p>		<p>Robust hinges designed for heavy use, with integrated locking in open and closed positions</p>		<p>Gas safety! Separation of the gas and electric chambers avoids any risks of explosion.</p>
	<p>Independent floating, swinging and adjustable motors for easy placement and removal of spits</p>		<p>Anti-scald K-glass reduces external thermal radiation (energy saving). Glass overlaps drip pan to keep splatters inside (anti-slip protection).</p>		<p>Removable inside side-panels double protection from grease seeping into motors and other sensitive parts.</p>

## ACCESSORIES

A variety of accessories are available. See video of available accessories online.

<p><b>CUI1425</b> Anti-cutting prongless V-spit</p>		<p><b>BPOR1425</b> Porchetta spit</p>		<p><b>BRC1425</b> Rectangular basket spit</p>	
<p><b>BS1425</b> Spit for ham / turkey</p>		<p><b>BRRO1425</b> Roast-clamp spit</p>		<p><b>BA1425</b> Lamb/suckling-pig spit</p>	
<p><b>BCR1425</b> Spatchcock chicken basket</p>		<p><b>DEC</b> Spit mover</p>		<p><b>PID1425</b> Tray for unspitting</p>	

Front view

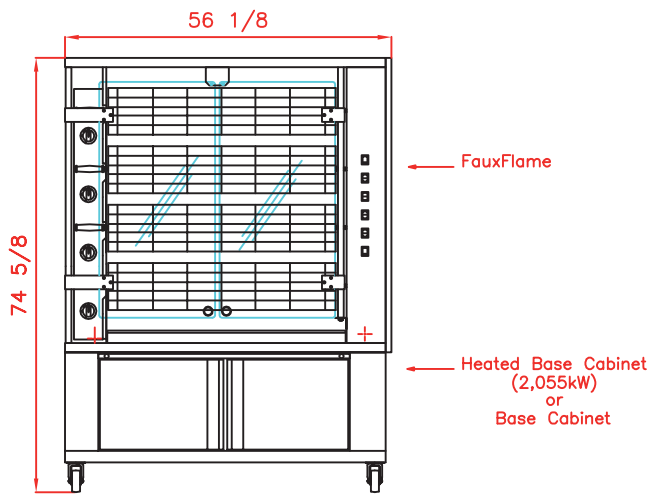

Top view

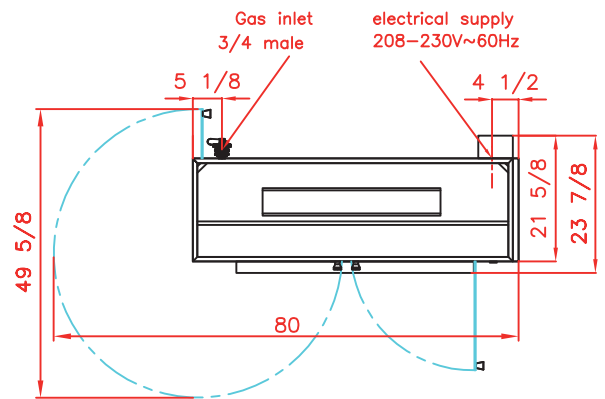

Side view

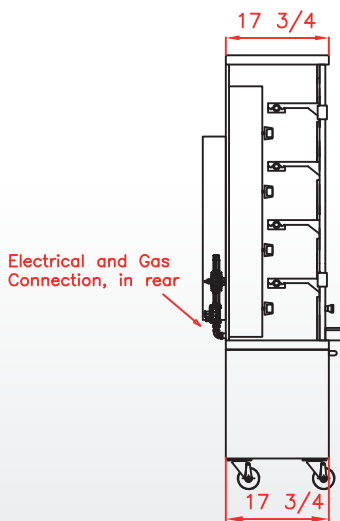

Revised  
December 2016  
April 2022 US



FF01425-4G-SS  
All Stainless Steel  
shown on optional cabinet

## SPECIFICATIONS

Capacity	16-20 open chickens, 20-24 whole chickens
Gas power	60500 BTU/h
Power supply	208-230V-60Hz; 2,5 Amps
Electrical power	0.47 kW
Weight and size (HxDxW)	375 Lbs; 74 5/8 x 23 7/8 x 56 1/8 inches
Shipping weight and size	530 Lbs; 76 7/8 x 30 x 57 1/8 inches
Warranty	1 year parts and labor

\* on stand or cabinet

DISTRIBUTOR / AGENT

Rotisol France, Inc.

1450 W. 228th St. Unit 10, Torrance, CA 90501

[info@rotisolu.com](mailto:info@rotisolu.com), [www.rotisol.com](http://www.rotisol.com)

Ph: 310 671 7254

800 651 5969