



FauxFlame™ FF1175-8G



DESIGN

The FAUXFLAME range of rotisseries has been designed with performance, practicality and mobility in mind. Light weight and compact FAUXFLAME is the ideal rotisserie for markets and food trucks and offers rapid production together with excellent cooking quality.

Conscious of the costs involved for our clients, the FAUXFLAME rotisserie has energy-saving infrared burners, patented by Rotisol, that enable the rapid roasting of a variety of products.

Shoppers are enticed by the attractive sight and appetizing smells of roasting poultry, beef, lamb, vegetables, and even fruit. An array of accessories allows for the rapid roasting of a wide variety of products.

FEATURES

- Independent motor for each spit
- 8 Prongless Chicken Spits with Bakelite handles
- Independent infrared gas burners with interchangeable ceramic bricks
- 2 K-glass doors (removable for transport)
- Bottom drip tray with drainage tap
- Optional lighting

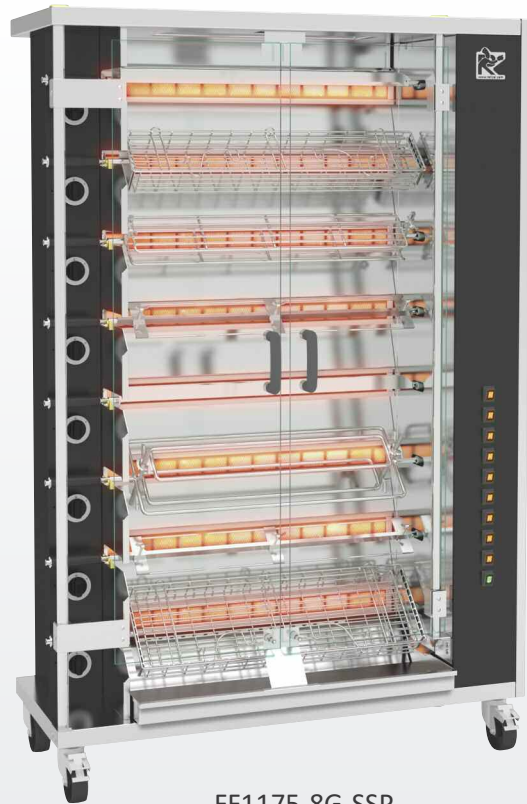

FF1175-8G-SSP
Black Porcelain Enamel & Chrome

TECHNICAL DETAILS

Overview of some of the standard features.

	Replaceable ceramic bricks for significant financial savings		Robust hinges designed for heavy use, with integrated locking in open and closed positions		Gas safety! Separation of the gas and electric chambers avoids any risks of explosion.
	Independent floating, swinging and adjustable motors for easy placement and removal of spits		Anti-scald K-glass reduces external thermal radiation (energy saving). Glass overlaps drip pan to keep splatters inside (anti-slip protection).		Removable inside side-panels double protection from grease seeping into motors and other sensitive parts.

ACCESSORIES

A variety of accessories are available. See video of available accessories online.

CUI1175 Anti-cutting prongless V-spit		BPOR1175 Porchetta spit		BRC1175 Rectangular basket spit	
BS1175 Spit for ham / turkey		BRRO1175 Roast-clamp spit		BA1175 Lamb/suckling-pig spit	
BCR1175 Spatchcock chicken basket		DEC Spit mover		PID1175 Tray for unspitting	

Front view

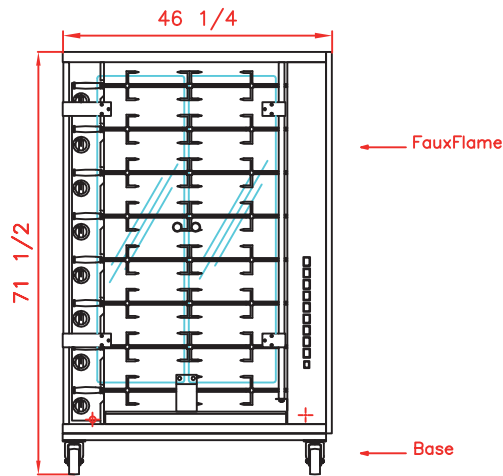

Top view

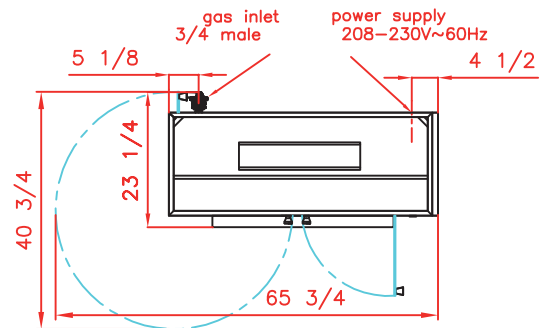

Side view

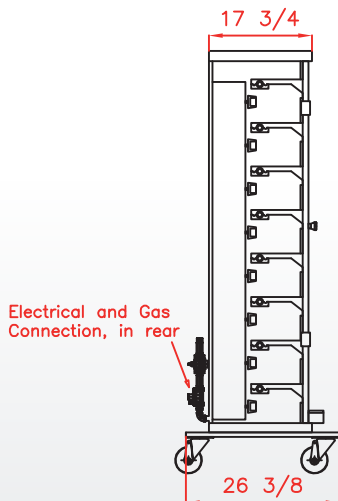

Revised
December 2016
April 2022 US

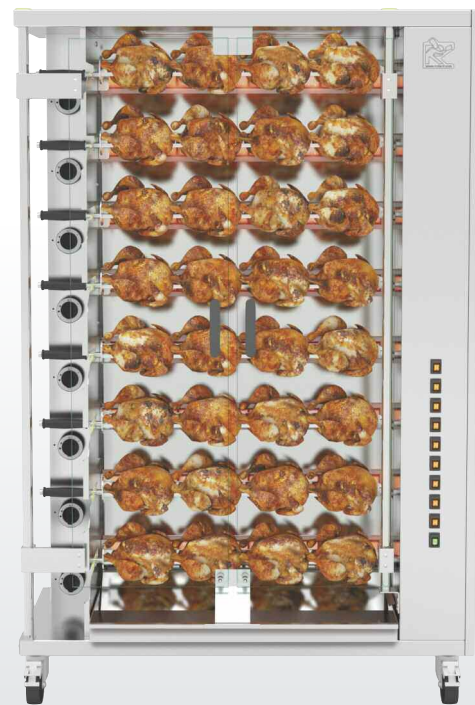

FF1175-8G-SS
All Stainless Steel

SPECIFICATIONS

Capacity	32-40 chickens
Gas power	82000 BTU/h
Power supply	208-230V-60Hz; 3 Amps
Electrical power	0.59 kW
Weight and size (HxDxW)	397 Lbs; 71 1/2 x 26 3/8 x 46 1/4 inches
Shipping weight and size	530 Lbs; 78 3/4 x 30 x 47 5/8 inches
Warranty	1 year parts and labor

DISTRIBUTOR / AGENT

Rotisol France, Inc.
1450 W. 228th St. Unit 10, Torrance, CA 90501
info@rotisolutusa.com
Ph: 310 671 7254
800 651 5969