



FlamBoyant™ FB1400-4G



DESIGN

The FlamBoyant range of rotisseries has been especially designed for high-volume cooking with high output and speed, while retaining excellent cooking quality. Well designed, user friendly and reliable, the FlamBoyant is used by leading supermarkets and chain restaurants throughout the world.

Conscious of the high energy costs involved for our clients, the FlamBoyant rotisserie has energy-saving infrared burners patented by Rotisol.

A wide array of accessories enables the rapid roasting of a variety of products.

FEATURES

- Energy efficient
- Tempered K-glass doors
- Independent motor for each spit
- Equipped with bottom drip tray with built-in drainage
- Rotisol patented burners
- Powerful halogen lamp
- Delivered with 4 prongless spits (CUI1375-1400)
- Illuminated "Rotisserie" sign for enamel model only
- Base or stand on casters with brakes



FB1400-4G-SSP
Black porcelain enamel and chrome
shown with optional lighted roof and stand

TECHNICAL DETAILS

Overview of some of the standard features.

	Replaceable ceramic bricks for significant financial savings		Robust hinges designed for heavy use, with integrated locking in open and closed positions		Gas safety ! separation of the gas and electric chambers avoids any risks of explosion
	Gas and electric switches, in chromed metal		Anti-scald K-glass reduces external thermal radiation (energy saving). Glass overlaps drip pan to keep splatters inside (anti-slip protection).		Removable inside side-panels doubles protection from grease seeping into motors and other sensitive parts

ACCESSORIES

A variety of accessories are available. See video of available accessories and of vertical spit system online.

CUI1375-1400 Anti-cutting prongless V-spit		BPOR1375-1400 Porchetta spit		BRC1375-1400 Rectangular basket spit	
BS1375-1400 Spit for ham / turkey		BRRO1375-1400 Roast-clamp spit		BA1375-1400 Lamb/suckling-pig spit	
BCR1375-1400 Spatchcock chicken basket		DEC Spit mover		PID1375-1400 Tray for unspitting	

Front view
Rotisserie with roof

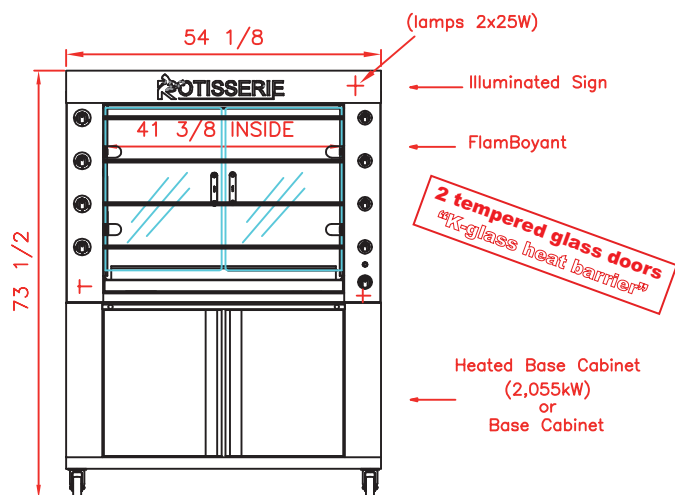

Top view
Rotisserie with roof

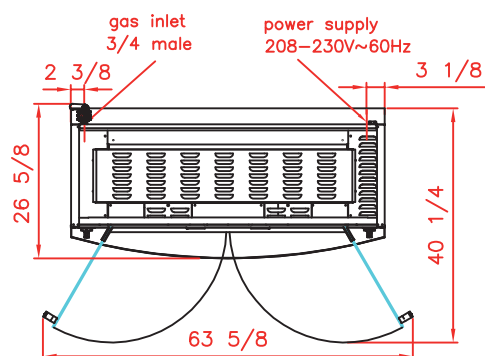

Side view
Rotisserie with roof

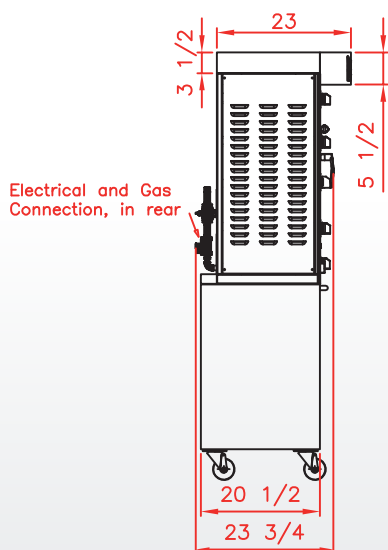

Revised
December 2016
April 2022 US



FB1400-4G-SS
Stainless steel & chrome
shown with optional roof and base

SPECIFICATIONS

Capacity	20-24 chickens
Gas power	76,000 BTU/h
Power supply	208-230V-60Hz/1ph, 4 amps
Electrical power	0.77 kW
Weight and size (HxDxW)	455 Lbs ; 73 1/2 x 26 5/8 x 54 1/8
Shipping weight and size	567 Lbs ; 74 7/8 x 30 3/8 x 58 1/4
Warranty	1 year parts and labor

DISTRIBUTOR / AGENT

Rotisol France, Inc.
1450 W. 228th St. Unit 10, Torrance, CA 90501
info@rotisulusa.com
Ph: 310 671 7254
800 651 5969