

# 5070

## Reach-in Freezers

Model #: MEF23-A, MEF49-A,  
MEF72-A

### Product Details

#### Exterior:

- 430 Stainless Steel
- Self-closing doors
- 90° stay-open feature
- Magnetic door gasket(s)
- Recessed handles for easy opening/cleaning
- Digital controls and LED temperature display
- Security lock with key
- Rollers (4) and leveling feet (2)

#### Interior:

- Aluminum
- Fully adjustable heavy-duty epoxy-coated wire shelves (4)
- LED lighting
- Auto-defrost system
- Bottom-mounted compressor

Not suitable for installation in non-commercial or residential applications.



MEF23-A



MEF49-A



MEF72-A

### Specifications

Model	External Dimensions	Internal Dimensions	Nominal Capacity	Holding Temperature Range	Doors/Shelves	Refrigerant Type	Electrical	Amp Draw
MEF23-A	27" x 34" x 81"	22.25" x 29" x 51.37"	23 Cu Ft	-10°F to 10°F	1 / 3	R290	115V/60Hz/1Ph	3.1A
MEF49-A	54" x 34" x 81"	49.25" x 29" x 51.37"	42 Cu Ft	-10°F to 10°F	2 / 6	R290	115V/60Hz/1Ph	7.2A
MEF72-A	81" x 34" x 81"	76.25" x 29" x 51.37"	65 Cu Ft	-10°F to 10°F	3 / 9	R290	115V/60Hz/1Ph	7.9A

5070 reserves the right to make changes to the design or specifications without prior notice.

APR2524



## Reach-in Refrigerators

Model #: MEF23-A, MEF49-A, MEF72-A

MEF23-A

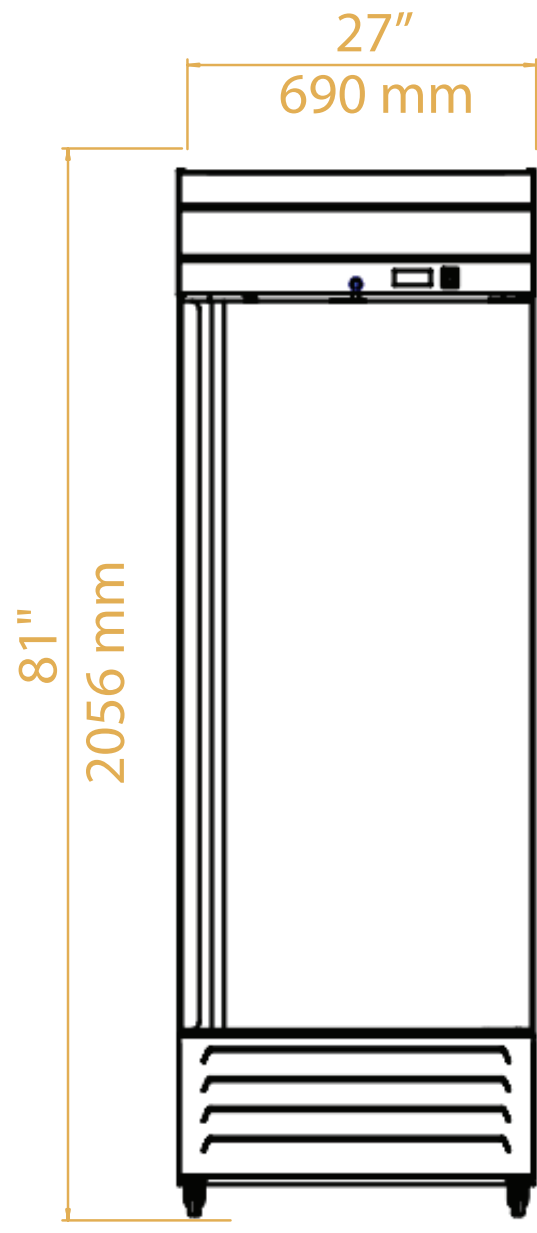

MEF49-A

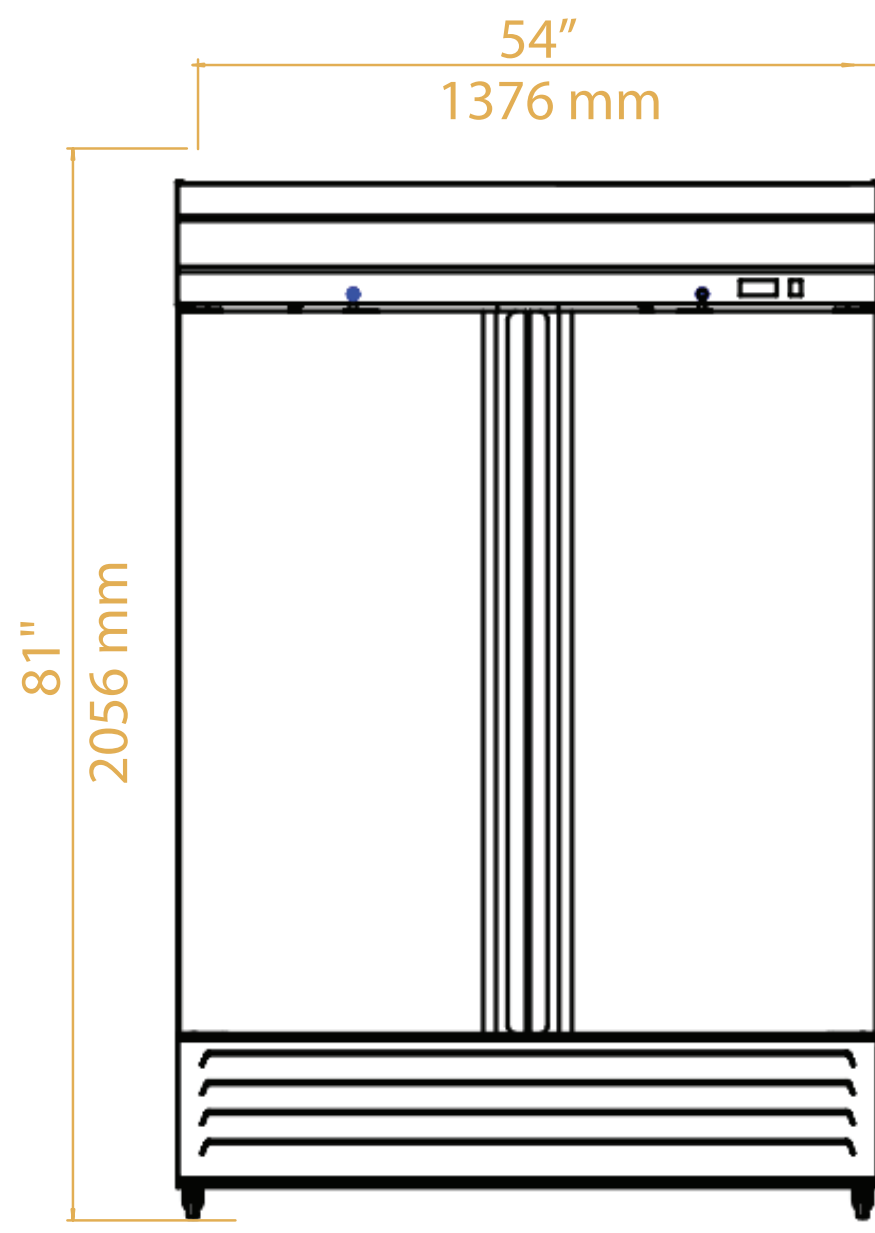

MEF72-A

