



DANTE SERIES STANDARD-PROFILE COUNTERTOP CHARBROILERS

SERIES: C-R



Bakers Pride® C-R series charbroilers feature a standard-profile design and 36,000 BTUH H-burners for energy efficiency and broiling performance. Models come in a range of sizes from 24" to 72" wide. Stainless steel radiants come standard, as do steel floating rod grates, which may be adjusted in four separate titling positions for increased flexibility and temperature control.

A continuously lit, cross-over pilot tube system makes lighting burners quick and easy. Fully insulated, double walls help with heat retention, while stainless steel interior and exterior construction makes this charbroiler both durable and easy to clean.

This series also offers many options to suit your needs, such as log holders or Glo-Stones for enhanced flavor and work decks for added convenience.

FEATURES AT A GLANCE

- 24.5" (622 mm) tall
- 36,000 BTUH H-burners every 4" (102 mm)
- H-burners are controlled with a single valve
- Natural gas or liquid propane
- Steel floating rod grates (standard) or cast-iron or meat grates
- Continuously lit crossover pilot tube
- Double-walled, fully insulated construction
- Stainless steel exterior, interior, and combustion chamber
- Stainless steel radiants
- 3.25" (83 mm) deep stainless steel slide-out grease drawer/ water pan
- 2.25" (57 mm) adjustable broiler
- 1" (25 mm) NPT rear gas connection
- Towel bar
- One-year limited warranty

OPTIONS & ACCESSORIES

- Cast-iron radiants
- Glo-Stones (field convertible)
- Log holder
- Natural woodsmoke essence box
- Removable steel griddle plate
- Cut-outs in extra deep work decks for saucepans
- 48" (1219 mm) gas connector hose (with or without restraining cable)
- Stainless steel splash guard
- Overhead back shelves with additional grates
- Condiment rail
- Warming rack
- 10" work deck





DANTE SERIES STANDARD-PROFILE COUNTERTOP CHARBROILERS

SERIES: C-R

EQUIPMENT DIMENSIONS

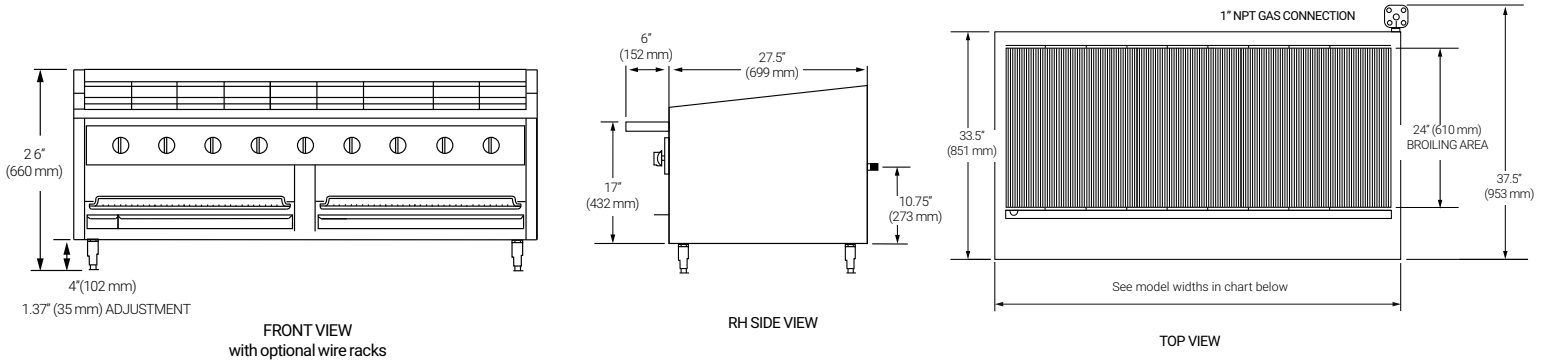

MECHANICAL SPECIFICATIONS

Model #	BTU	KW	# Grates	# Burners**	Broiling Area	Overall Dimensions (W x H* x D*)	Carton Dimensions (W x H x D)	Cubic Feet	Cubic Feet	Ship Wt.
C-24R	90,000	26.38	4	2.5	21" x 24" (533 x 610)	24" x 26" x 37.5" (6108 x 660 x 953)	34" x 46" x 42" (864 x 1168 x 1067)	23.7	.7	260 (117kg)
C-30R	108,000	31.65	5	3	27" x 24" (686 x 610)	30" x 26" x 37.5" (762 x 660 x 953)	34" x 46" x 42" (864 x 1168 x 1067)	44.4	1.2	330 (150kg)
C-36R	144,000	42.20	6	4	33" x 24" (838 x 610)	36" x 26" x 37.5" (915 x 660 x 953)	51" x 46" x 42" (1295.4 x 1168 x 1067)	44.4	1.2	400 (182kg)
C-48R	198,000	58.03	8	5.5	45" x 24" (1143 x 610)	48" x 26" x 37.5" (12198 x 660 x 953)	51" x 46" x 42" (1295.4 x 1168 x 1067)	44.4	1.2	440 (200kg)
C-60R	252,000	73.85	10	7	57" x 24" (1448 x 610)	66" x 31" x 43" (1676 x 787 x 1092)	34" x 46" x 42" (864 x 1168 x 1067)	39.1	1.1	585 (266kg)
C-72R	306,000	89.68	12	8.5	69" x 24" (1753 x 610)	78" x 44" x 46" (1981 x 1118 x 1168)	34" x 46" x 42" (864 x 1168 x 1067)	59.3	1.7	877 (398kg)

*Height includes 4" adjustable (102 mm) legs. Depth includes 4" gas regulator.
 **Each H-burner has an output of 36,000 BTUH and is controlled by a single valve.
 Some models have an additional single 18,000 BTUH burner that is also controlled by a single valve.

REQUIRED CLEARANCES

	Combustible
Left	10" (254 mm)
Right	10" (254 mm)
Back	10" (254 mm)

GAS CONNECTIONS

Natural or LP gas
 1" NPT rear gas connection

Bakers Pride reserves the right to modify specifications or discontinue models without incurring obligation. Dimensions nominal.



Freight Class: 70
 FOB: 75013

4.20.2020

