



## Installation and Operation Manual

Northwind Blast Chiller

Models: 500 and 1000



Bally Refrigerated Boxes, Inc.

**1-800-24BALLY**  
[www.ballyrefboxes.com](http://www.ballyrefboxes.com)

# Introduction

## **READ ENTIRE MANUAL BEFORE BEGINNING INSTALLATION!**

- There are 9 steps to the installation process. This manual gives you a correct sequence to follow as you prepare for and carry out installation.
- Prior to the day you make the installation, be sure to review the tool list and parts list, and the illustrated plan so that you can complete the installation in a reasonable time without any problems.
- There is also a precise wiring diagram included for any complication and step-by-step instructions to make the job that much easier.
- No manual can anticipate every field situation, but if there are any questions not answered here, please feel free to call the Bally Northwind help desk at 800-242-2559. Our staff of troubleshooters will do their best to assist you.

# Table of Contents

<b>Title</b>	<b>Page Number</b>
Introduction .....	1
Tool List .....	4
Parts List.....	4
Step 1 – Locating the Blast Chiller.....	5
Step 2 – Panel Preparation .....	5
Step 3 – Erection of Vertical Panels.....	6
Step 4 – Installation of Ceiling Panels.....	7
Step 5 – Secure all Panel Sections .....	8
Step 6 – Installation of the Controller .....	8
Step 7 – Installation of Coil & Fan Assemblies.....	9
Step 8 – Cable Connections.....	12
Steps 9 - 11 – Final Assembly .....	12
Operation Introduction.....	13
1 - Controller Description & Operation.....	14
2 – The Probes.....	14
3 – Automatic Mode.....	14
4 – Defrost Mode .....	16
5 – Manual Mode.....	17
6 – The Red Light (Critical Failures) .....	17
7 – Maintenance Items .....	18
Major Component of the Blast Chiller .....	Back Cover

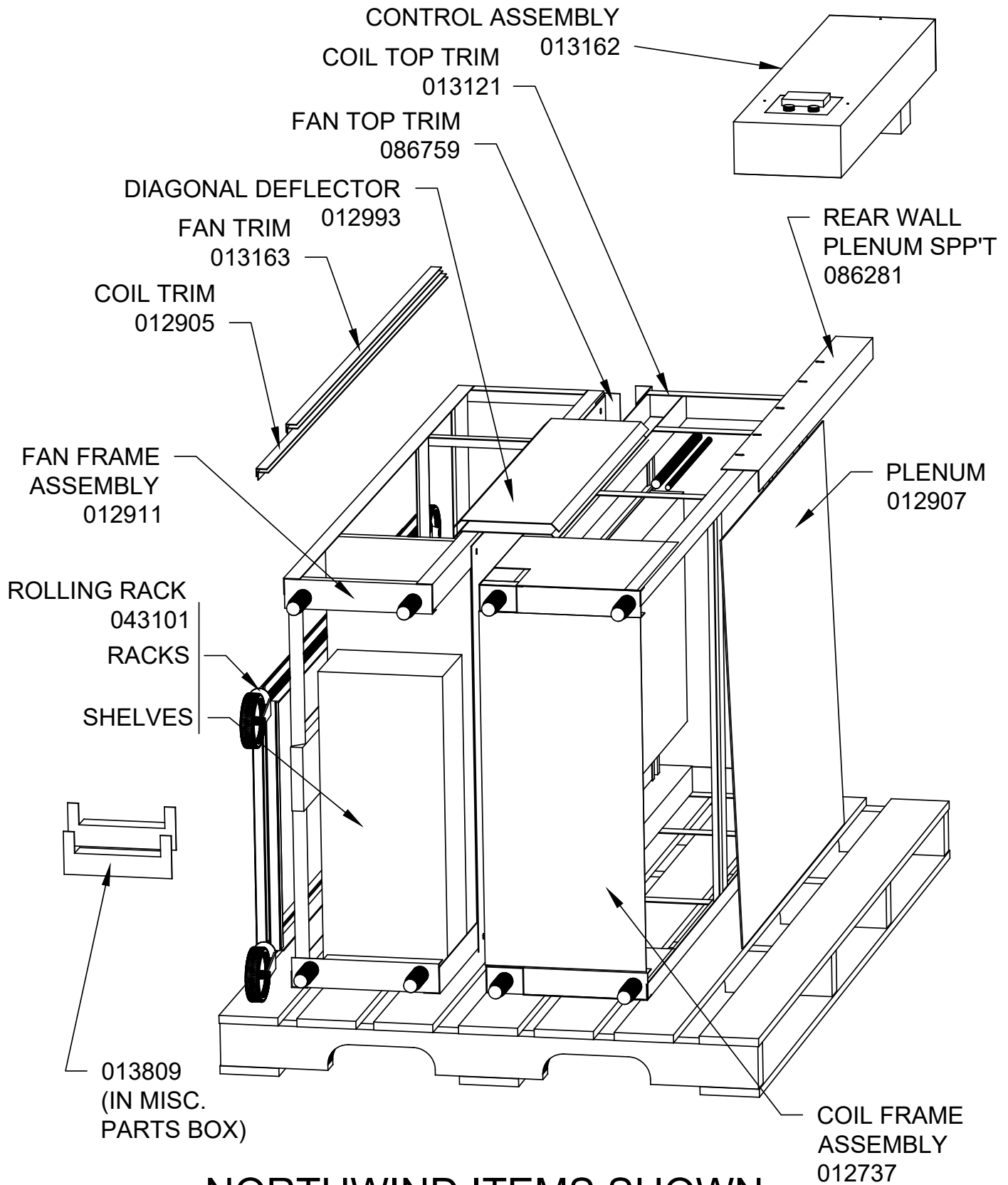

## NORTHWIND ITEMS SHOWN AS THEY ARRIVE ON THE PALLET

Note: 012993's are sometimes left out (see Chapter. 6.3)

## Bally Northwind Tool List

Two people are required to assemble a Bally Northwind. The following list will assist you on the tools necessary in the assembly process.

1. Caulk Gun (tube type)
2. Utility Knife (for foam insulation)
3. Speed Lock Wrench (in general miscellaneous box\*)
4. Tape Measure
5. Level (at least 4 ft.)
6. 5/16 Nut Driver
7. Straight Edge (i.e., carpenters square)

\*You will find two Miscellaneous Parts Boxes: the General Box, with parts for the normal walk-in portion of the job, and the Blast Chiller Miscellaneous Box, with dedicated parts of the Blast Chiller.

## Bally Northwind 500 Parts List

1. 23" Panels [3]
2. 34 ½" Panel [1]
3. Corners [4]
4. Ceiling Panels [2]
5. 36" x 78" Door (with electrical junction box, complete with twist-lock plug wiring). [1]
6. Control Panel (with complete twist-lock plug wiring and buzzer with alarm switches) [1]
7. Fan rack (pre-assembled) with twist-lock plug wiring [1]
8. Evaporator Coil (pre-assembled) with twist-lock plug wiring [1]
9. Probes, thermocouple type K [3]
10. Ceiling Plenum with light and twist-lock plug wiring [1]
11. Top Coil Trim with J-box for Thermocouples [1]
12. Top Fan Trim Piece [1] (Angled piece, approx. 4 x 36")
13. Coil and Fan Trim Pieces [2 each]
14. Top Diagonal Air Deflectors (for above Coil and Fan assembly) [2].
15. Universal food rack with tray supports [1]
16. Door Anchor [2] (UNLESS there is a floor)
17. ¾" Stainless steel plug buttons, type 304 (48)
18. Grey panel gasket for repair of damaged gaskets

## 1. Locating the Blast Chiller

- 1.1. Using a chalk line and a carpenter's square, locate on the building floor, the exact dimensions of the blast chiller as shown in the supplied print. After marking the exterior rectangular dimensions, measure inward 4" around the perimeter to form an interior rectangle, which locates the interior blast chiller dimensions. Applicable on stand-alone box.

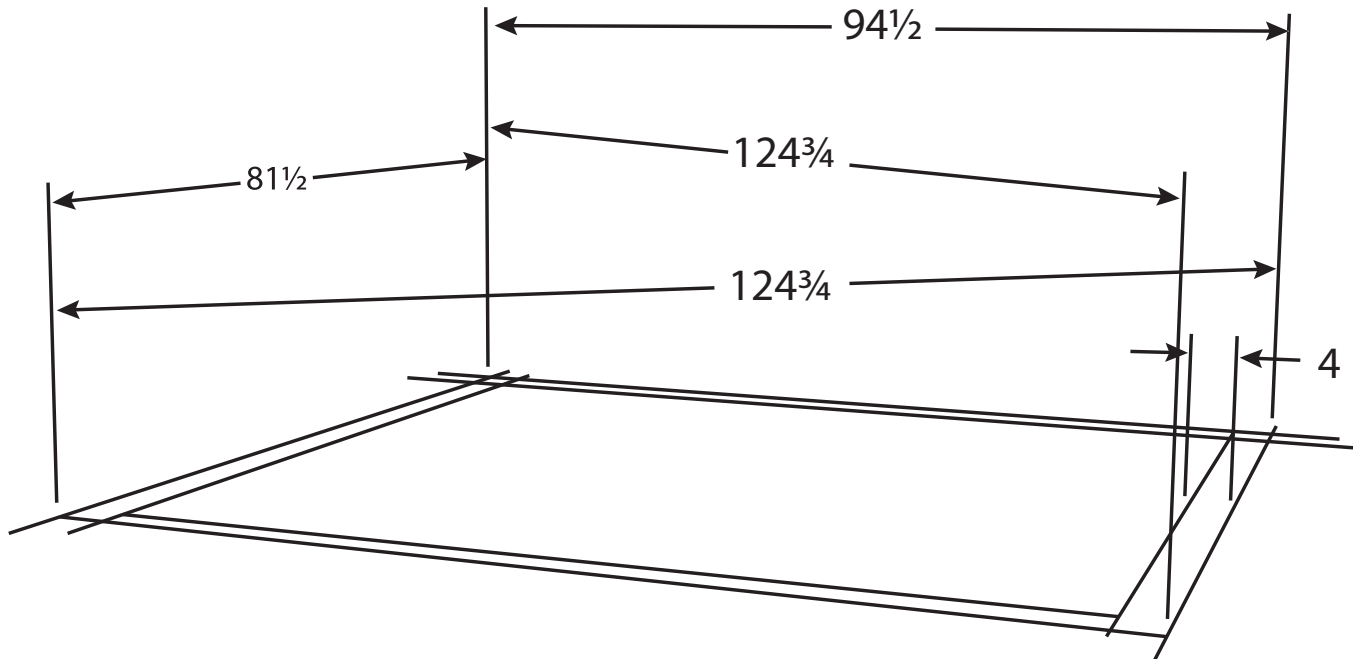

## 2. Panel Preparation

- 2.1. Remove all protective paper from panels. Leave all special labels on the skins.
- 2.2. During the course of installation, the panels must be caulked for proper seal. This detail is to be applied to all panel joints throughout this instruction. Using the tube of clear silicone supplied, run two [2] vertical beads of caulk (see drawing 1.1) on the interior foam seams.

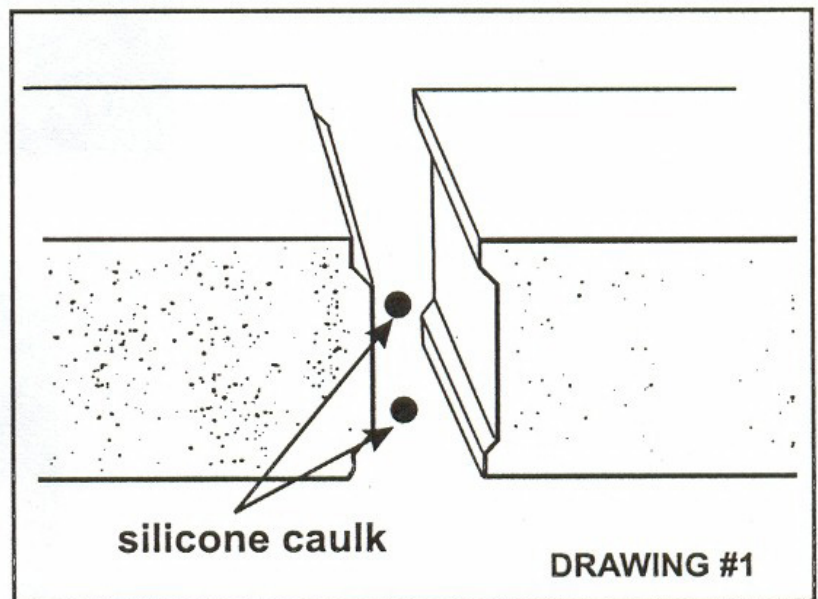

### 3. Erection of Vertical Panels

#### 3.1 BEFORE ATTEMPTING TO ERECT ANY PREFAB SECTIONS, FAMILIARIZE YOURSELF WITH THE FOLLOWING CHAPTERS IN THE STANDARD INSTALLATION MANUAL

- Page 4, Section 1  
Operation of the Bally Speed-Lok
- Page 5, Section 2  
Operation of the Bally Speed-Lok
- Page 7, Section 3  
Bally Boxes without Floors

- 3.2 Start by erecting a vertical rear corner section.  
When erecting, the holes for the Speed-Lok wrench must always be on the left-hand side when facing the interior section. This is important; crews have installed boxes upside down

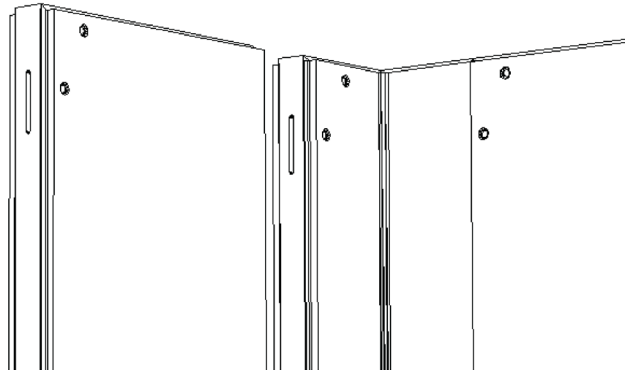

#### Panel assembly sequence of a Northwind 500

- The Coil Frame Assembly is installed in the box before the door is added since the coil is taller than the opening of the door. You'll have to slide the coil out of the way to lock the last corner panel.
- When erecting the front sections of the box, note that the door latch corner and the door frame section have a cut out at the top of the panels, which, when joined, will provide a slot through which the collar of the control panel will be inserted.
- Install this cut out corner first, making sure that the two bottom surfaces in the notch area are perfectly level.

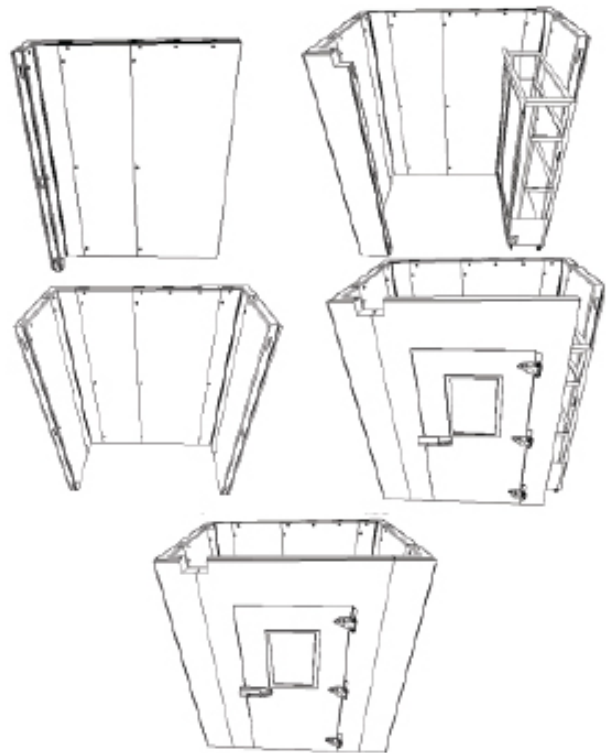

For the NW 1000 sequence, look in the Appendix.

3.3 On each panel, check for proper alignment and level. Leveling can be accomplished by placing –wooden shims under the vertical panels (cross-reference IM-268-11, Section6).

3.4 Remove the shipping strap attached to the bottom of the door opening. When attaching the door, hold a level on the face of the door section, and when plumb, Speed-Lok to adjacent corner section. **IT IS VERY IMPORTANT THAT THE DOOR SECTION IS ALWAYS LEVEL AND PLUMB.**

#### 4. Installation of the Ceiling Panels

4.1. Bring the rear ceiling panel on top of the front half of the blast chiller.

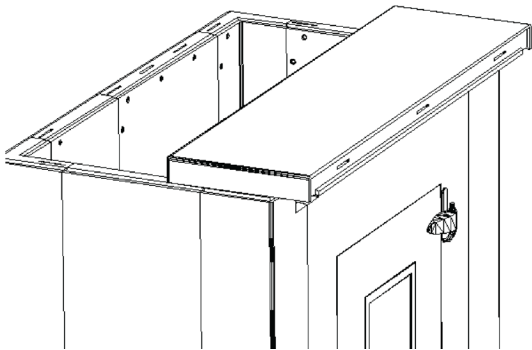

4.2. Caulk on both sides of the tongues of all the appropriate rear wall panels.

4.3. Pick up the ceiling panel, bring it back, and drop it in place. Engage a couple of locks on the back wall. **Do not fully lock.**

4.4. Caulk the groove or tongue of the rear ceiling panel and the rest of the wall tongue area.

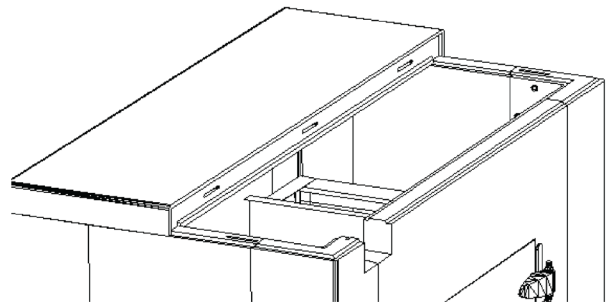

4.5. Bring up the front ceiling panel and lock it to the back ceiling panel, fully engaging the Speed-Loks to the lock position on the seam between the two **ceiling panels.**

4.6. Make sure the ceiling panels are secured squarely on the vertical panels. **Do not fully lock.** Align and adjust accordingly.

4.7. Fully engage the Speed-Loks to the lock position on the **vertical panels** to the ceiling panels.

#### Installing Ceiling Panels on the Northwind 1000

- Install the middle ceiling panel first. The large panel will align more panels quicker.
- Instead of caulking the tongues, place the caulk in the corners of the grooves in the ceiling panel, then lay the ceiling panel on a piece of cardboard trimmed to size.
- Lift the ceiling and cardboard onto the verticals, locate the ceiling panel, tilt it up, and remove the cardboard.

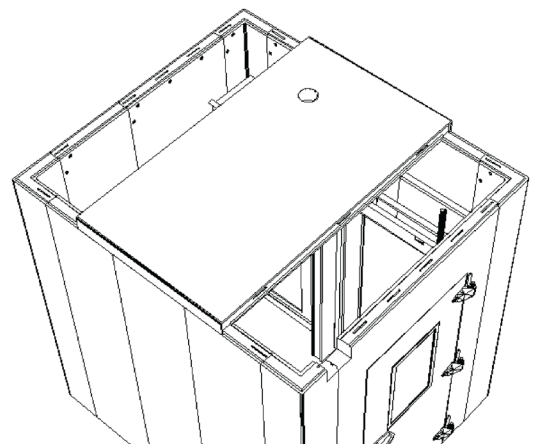

## 5. Secure all Panel Sections

- 5.1 After all Speed-Loks are secured, install access hole plug buttons to all Speed-Lok locations.
- 5.2 Anchor both sides of the doorframe inside the box to the floor with "L" braces with 5/16" expansion bolts and 5/16" hex head self-tapping screws with shoulders to the door panel.
- 5.3 Using the silicone supplied, caulk both interior and exterior of box at floor joints.
- 5.4 Install SS continuous angle floor anchor (Bally PN 019045) around inside periphery of the box.

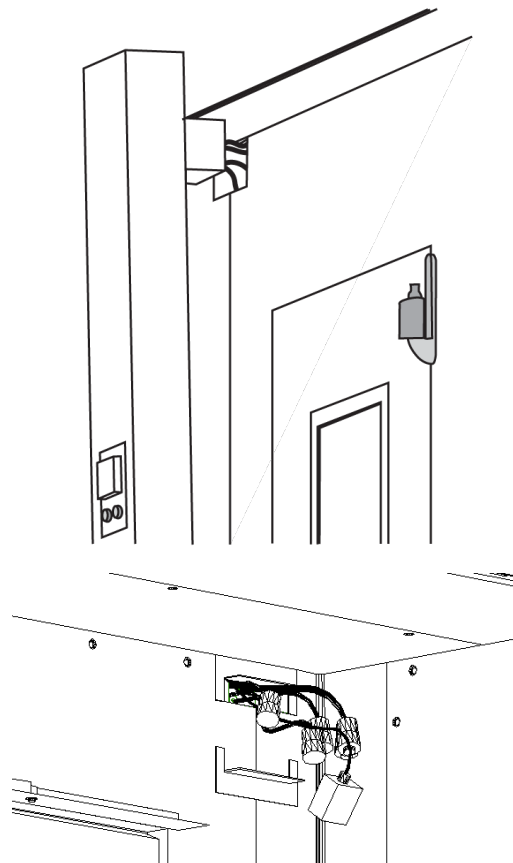
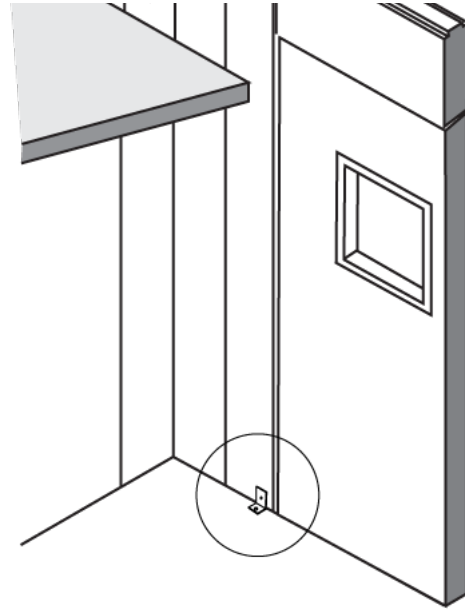
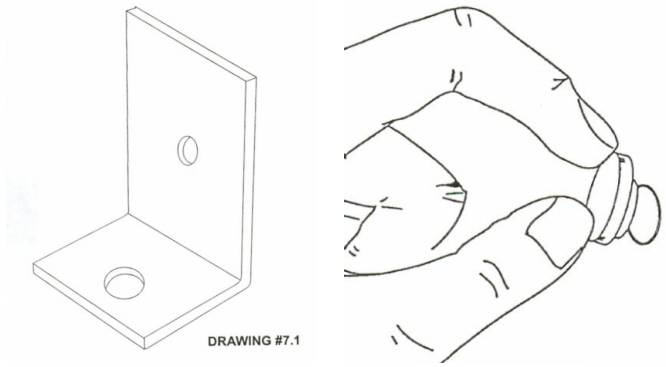

## 6. Installation of the Controller

- 6.1 Have a partner hold the controller up and feed the connectors through the controller slot in the front of the box. Then push the rectangular collar of the control assembly into the slot until the base of the controller is against the face of the blast chiller. Back out the three screws that hold the front cover onto the controller base. Remove the controller cover, and screw the controller base to the wall panel.
- 6.2 Two interlocking stainless steel harness covers lock around the incoming cables of the control panel. Secure the cover plates to the box front panels by preparing a pilot hole with 1/8" drill and finishing with 1/2" stainless steel, self-tapping, Phillips head sheet metal screws. Fill the volume with canned foam. Fill any gaps between the wall panels and the plastic wrapped chute with canned foam.

6.3 Install the two top ceiling deflectors in the upper top corners of the sides of the box deflecting the flow of air from the fan frame assembly to the coil frame assembly. Prior to installing, prepare 1/8" pilot holes and use 3/4" stainless steel, self-tapping, Phillips head sheet metal screws.

Some tall (over 106") boxes may not have ceiling deflectors. Check the packing list for PN 012993.

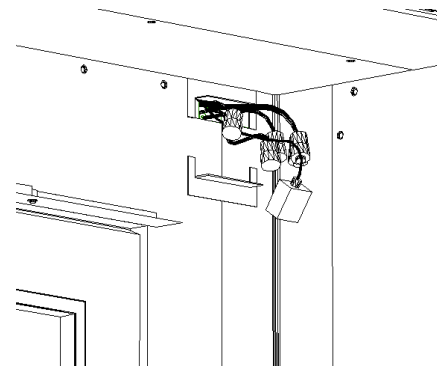

## 7. Installing Coil and Fan Assembly Frames

7.1 Before you stand up any of the frame assemblies, extend the legs out to 5.0" (by spinning the foot pads).

7.2 Installing the Coil Frame Assembly

1. Remove the Coil Top Trim, 013121.
2. Install the coil frame into the appropriate side.
3. Center the frame within 1/16" between the two walls.
4. Install screws into the rear top back brace. This will force the frame against the wall permanently.

5. Reinstall the top coil trim piece. Attach the grey plastic probe receptacle box (from the controller) into the rectangular hole

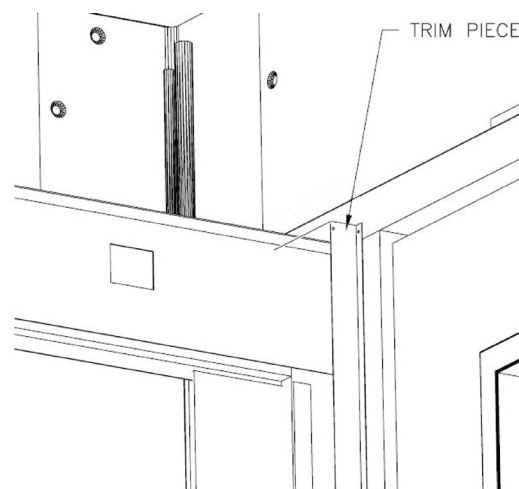

**NW 1000**

**NW 500**

**Orientation of the Trim Pieces**

The Bally box design follows certain rules. One of the results is that a wall that two corners on it will be 1/2" narrower than a wall made of a corner and a breaker. As a result of this, there is more room in a NW1000 than a NW500. To make up for this extra space, the trim pieces are turned with the long legs against the frame on a NW1000, long legs against the walls on a NW500.

### 7.3 Installing the Fan Frame Assembly

1. First remove the fan guard.
2. Install the frame in the appropriate side and screw the back braces to the side wall using the same stainless steel sheet metal screws.
3. Plug in the Air Probe (see connector at top of picture).
4. Install the two shorter side trim angles on each side by screwing them to the walls.
5. Replacing the front cover will capture the side trim pieces between the front cover and the frame.
6. Place the Top Fan Trim Piece between the same front cover and the frame.

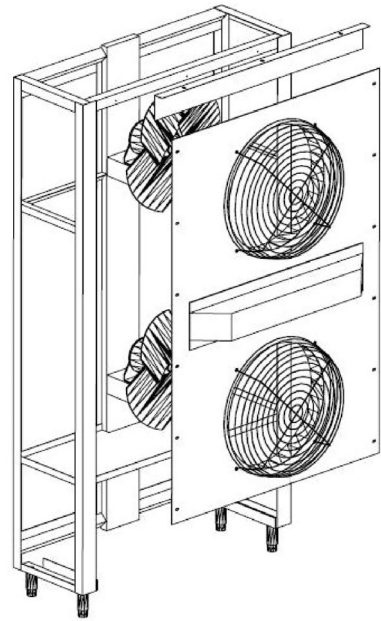

### 7.4 Installing the Condensate Drain

1. A tube must be installed to drain condensate from each coil assembly.
2. Find the pan, which is approximately four inches above floor level on the coil frame. Locate the 90° Elbow beneath it.
3. You must supply a drain line starting from the ¾" NPT plastic elbow. You may plumb the line to the front, rear, or side, as per your convenience. You may use plastic tubing, PVC pipe, or other pipe. If you are installing a NW1000, you may join the two runs or plumb them separately.
4. Drill a hole in the appropriate panel. Caulk the hole(s) after finishing the plumbing.

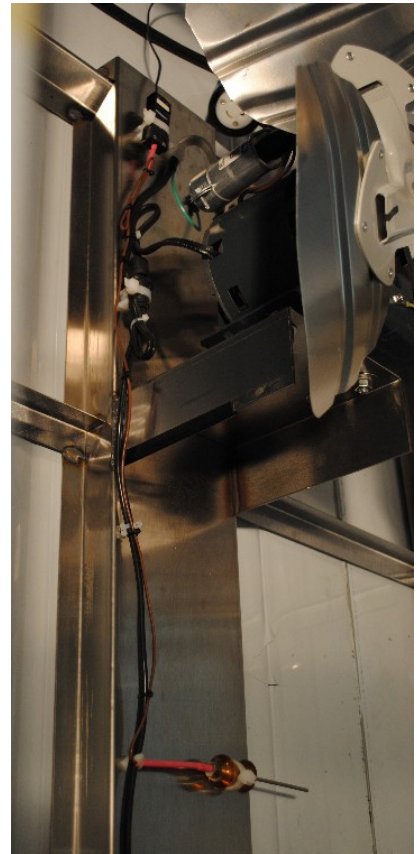

## 7.5 Installing the Plenum Supports and Plenum

1. At this point, the Front Plenum Support, Fan Seal Strip, and Coil Top Trim should be in place. Adjust the side pieces so that they match the front in height (usually 78").

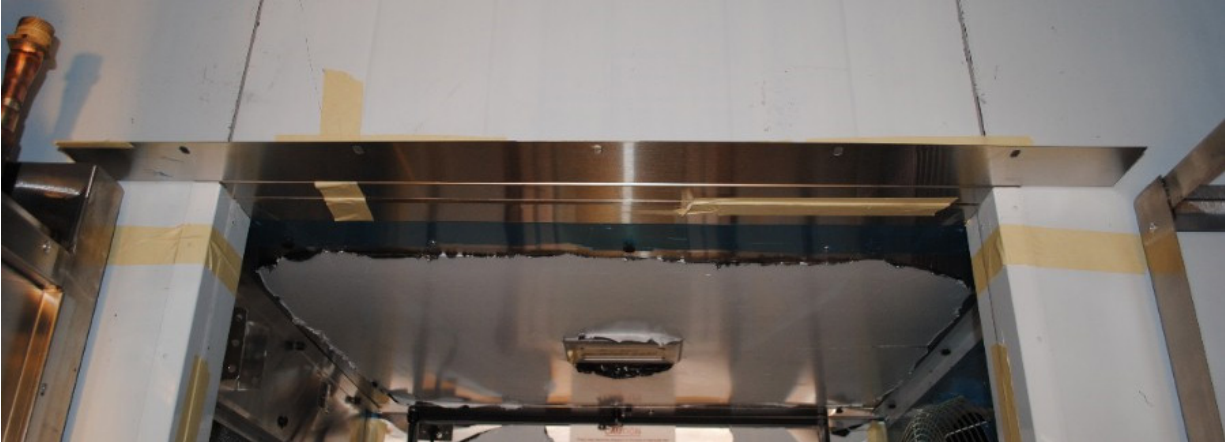

**Interior Plenum Supports** on both sides of the interior wall of a NW1000. The plenum is installed on the far side of the wall.

2. Add the Interior/Rear Plenum support(s) to the interior wall (on a NW1000) and rear walls. You will find screw holes in the walls from our initial assembly. Use these first.

**Plenum Installation** - Towards the coil frame, lift the Plenum diagonally over the fan assembly; raise it until the lowest corner is above all the Plenum supports; lower it flat on supports.

3. Install the Plenum and see if the holes line up.  
Screw the Plenum to the:
  - (1) Front Plenum Support, then
  - (2) The Coil Top Trim\*, then
  - (3) The Fan Top Trim, and finally
  - (4) The Rear Support (or the Interior Support for the NW1000).

\*The priority should be in that order, if the Coil Top Trim holes won't match up when the plenum is screwed to the Front, unscrew the Coil Frame from the wall and shift it over until it fits. The Fan trim piece can shift side to side with respect to the frame, and you can redrill the holes in the back wall.

## 8. Cable Connections

- All of the interior wiring is done utilizing color-coded, twist-lock, watertight plugs and type J thermocouple plugs. Make sure all plugs bottom out.
- All interior wiring must be done before the ceiling plenum is installed.

### 8.1 Interior Wiring Color Code

1. TWIST LOCKS from -  
Controller to:
  - Red → defrost heaters
  - Blue → solenoid valve & defrost termination
  - Green → fan motors
  - Yellow & Brown → door junction box
2. "Grey +" = "Back side of NW1000". For example:
  - Grey & Red → rear defrost heaters
3. Type J Thermocouples
  - Three Cables Terminating at Outlet Box(es)
  - Air probe Cable (single black receptacle)
4. Match all of the plugs together according to the color code provided. Ty-Wrap all of the cords to the bases attached to the walls for that purpose. You will want to leave the Plenum down for the refrigeration technician, and it will not matter as far as the electricity is concerned if you leave the plenum out of the blast chiller.

## 9. Hooking up the System

A properly licensed electrician must next hook up the system to a shut off attached to a nearby wall. The electrical specifications are located on a sticker attached to the controller.

## 10. Installing Refrigeration

After the unit has power, the refrigeration technician can install the refrigeration, running ½" and (usually) 1- 1/8" copper tubing through the provided hole in the ceiling panel. Make sure the suction tubing is properly wrapped with Armaflex, and all work is done in good practice according to local code. Coils arrive with a holding pressure of 60 psi nitrogen.

## 11. Setting the Ceiling Plenum

The ceiling plenum can now be set in place, plugged in, and mounted using black thumb screws. If you have trouble lining up the holes, remember that the fan side upper trim is clamped in place and can be slid forward or backwards, and you can loosen the trim piece over the coil frame as well. Also remember that the interior plenum support angle can be relocated if need be.

# OPERATIONAL MANUAL: BALLY NORTHWINDS BLAST CHILLER

BEFORE TURNING THE CONTROLLER ON, ensure that all wire connections are secure and correctly color coded.

Inspect all of the external wiring according to the wiring specifications.

WARNING: DO NOT OPERATE THE NORTHWINDS CONTROLLER WHEN THE CONTROL COVER HAS BEEN REMOVED.

## 1. The Control Panel:

- On/Off Power Switch for the unit.
- Backlight for screen is always on, unless power is shutoff at the breaker box.
- Operational Alarm displays red in a critical failure. (See #11)  
Push to silence Alarm.
- F1 thru F4 are referenced from the screen.
- Previous/Next are shown when you can page through multiple screens. (See Auto & Manual Mode)

## 2. The Probes

**Air Probe:** Monitors air temperature

**Product Probe:** Monitors food temperature that the Blast Chiller used in Auto Mode.

**Auxiliary Mode:** Monitors food temperatures in other locations for data collection only.

## 3. The Stages

**Chilling:** This is where the Blast chiller chills the food as quickly as possible. The air temperature is driven to 5°F.

- If the air temperature goes below 5° the refrigeration will turn off for 3 minutes.
- If the door is opened, the fans and refrigeration will turn off. When the door is closed, the fans turn on and the refrigeration turns back on for 3 minutes after the door was originally opened.

**Holding:** The unit is holding the food until the user removes it from the blast chiller. The air temperature is kept below 45°F.

- If the air temperature goes above 45° the refrigeration will turn on for three minutes.

## 4. Modes of Operation

The Northwinds blast chiller has 3 different Modes or Cycles of operation.

**Automatic:** Default Cycle. Fans and refrigeration cool food to 36°F using the Product Probe (inserted in the middle of the product) to determine when the cycle is complete.

**Manual:** Instead of inserting the Product Probe, a chilling time is entered in the controller. After the time is up the Northwind enters Auto mode.

**Defrost:** Melts the ice that may have accumulated on the coil, then returns to Auto mode.

## 5. Automatic Mode

- Put food cart into the Northwinds.
- Insert Product probe and Auxiliary Probes in the middle of the tray of food.
- Close the door.
- Turn the Northwinds on.
- The fans and refrigeration will turn on until the Product probe temperature reaches 36°F.
- The system moves into the Holding stage. The refrigeration is off, but the fans stay on.

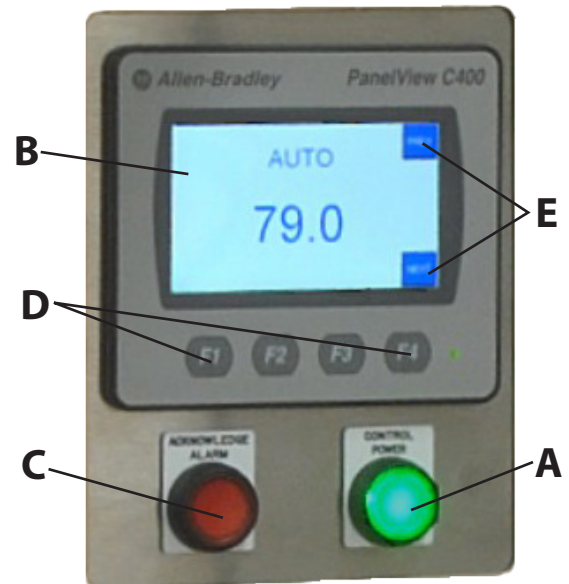

## 6. The Display Screens in Automatic Mode:

While in automatic, you can push the Next/Previous buttons on the display to page through information appropriate for this mode. When the automatic mode begins, you will see the word "AUTO" and the product temperature. As you push the **next** arrow, you will see the following screens:

Screen Reads	Appears When
Probe Temperatures:	Show temperatures for the Air, Product, and Auxiliary Probes.
Chill Time:	Indicates time since the food probe temperature went below 140°F.
Refrigeration Status:	This is an on/off indicator
Fault Page	Indicates if there are any faults (such as broken thermocouple circuits).
<b>Special Screens</b>	
Product temperature is close to air temperature	Product temperature and air are within 15°F of each other at the start.
Product Temperature Reached	Chill process has ended and the unit is in holding mode.

## 7. Defrost Mode

During the Defrost Cycle heaters in the evaporator coils will turn on (they stay on even if the door is opened). The Defrost Cycle will end after 20 minutes or by the Defrost Termination Switch (DTS, see #8). Following the completion of the Defrost Cycle, a timer countdown will be shown on the display screen while the refrigeration turns on for 3 minutes before the fans. This causes any water on the coil fins to freeze.

### To enter Defrost:

- After the Chilling cycle has been completed, remove the food cart, and push **F2**.
- You will be prompted to insert the password, which is: **22**.
- Push and hold the **+/-10's** button until you see 20.
- Push the **+/- 1's** buttons to reach 22.
- After 22 is showing on the screen, hit **F2** again.
- The Defrost Cycle will begin.

## 8. Defrost Termination System (DTS)

The defrost termination switch is a "switch with a memory" that turns on when it senses a temperature of 60°F, and stays on until it senses a temperature down to 20°F. It stays off until the temperature goes back up to 60°F again. In the blast chiller, once the air temperature gets down to 20°F during a cycle, you should be able to go into defrost immediately after using it. If the unit sits for a while and gets warm enough to melt all the ice on the coil without defrosting it, then the unit will let you know by displaying "Defrost not Needed" when F2 is initially pushed.

### NOTE:

- If the evaporator coil fills up with ice it can diminish the performance of your Northwinds.
- If the unit runs for three to six hours a day then remains idle, the Defrost Cycle typically isn't needed because the temperature rise will thaw and drain any ice on the evaporator coils.

## 9. Manual Mode

### To use Manual Mode:

- Turn the Northwinds on.
- Push **F3**.
- Insert the code, which is **22**, as described in "Defrost".
- Push **F3** again.
- Adjusting the Chilling Time to fit your needs (see Manual Time, #10).
- Put the food cart in the Northwinds.
- Insert food probes - *Optional*.
- Close the door.

The Chill Time chosen will be the length of time that the refrigeration system will run. When the chill time is up, the unit returns to Automatic Mode. If the product probe is in the food, it will continue to chill the food if the food is still above 36°F. Otherwise, the unit will be in holding stage.

## 10. The Display Screens in Manual Mode:

**Manual Mode:** Air temperature in large letters on the top line, followed by the total chill time in small letters, and the current time (Time since chilling started). As you push the down arrow, you will see the following screens in this order:

Screen Reads	Appears When
Measured Temperatures:	Show temperatures for the Air, Product, and Auxiliary Probes.
<b>Manual Mode Time</b>	Set the time for the manual cycle to run by following instructions on the screen. Any time changes take effect immediately.
Refrigeration Status:	This is an on/off indicator
Fault Page	Indicates if there are any faults ( <i>such as broken thermocouple circuits</i> ).

**11. The Red Light:** When there is a critical failure a red operational error light and an alarm turns on. Possible triggers are:

Error displayed on screen	Meaning
Air temperature above 100°	This is most likely due to a refrigeration failure. The unit will shut down so that the fans will not draw out even more heat from the food, perhaps triggering the fire suppression system. The food must be cooled some other way, and the refrigeration system must be serviced.
Fan contactor failure	This is a self-diagnosis by the controller. The fans will not come on if the fan contactor fails. Any food must be cooled elsewhere, and replace the contactor.
Defrost contactor failure	This is self-diagnosis by the controller. The unit will not defrost. This may not prevent acceptable performance, since it only effects defrost. Replace the contactor.
Air probe open	The air temperature input probe is not working correctly, and the unit cannot operate.

## 12. Item Maintenance Locations for Bally Northwinds Blast Chillers

Item	Part#	Location/Means of Access
Fan Motor	016915	Inside Fan Frame/Remove entire Fan Cover ( <i>not the wire fan guards</i> ).
Refrigeration Valve	005424	Part of the Liquid Line, left side of Coil Frame. Unscrew the 6 black topped screws, and remove coil filter and side cover.
Solenoid Valve	061514	Attached to the Refrigeration Valve. Part of the Liquid Line. ( <i>See above</i> ).
TXV	000388	Part of the Liquid Line ( <i>See above</i> ).
Power Head	099644	Attached to TXV, above ( <i>Special 60" bulb tube</i> ).
Defrost Switch	088779	In the top bend of coil frame, usually on the Liquid Line side. ( <i>Wired closely to the coil junction box.</i> )
Air Probe	046759	Behind the upper fan motor. Remove the Fan Cover ( <i>not the Wire guard</i> ).
Auxiliary Probe	089226	In plain sight. Plugged into top of coil frame.
LED Light	014936	Remove plenum screws, slide plenum to side so to access 3/8 nuts holding LED housing. Use 5/16 nut driver and 3/8 wrench to remove two hex head screws holding the LED housing in place. LED can now be unplugged and replaced.
LED Power Cord	061735	
Heater	016661	Coil assembly will have to be disconnected (refrigerant line, electrical, trim) and coil pulled forward until heater are accessible from back of coil.

**Probe plugs:** The temperature probes are low voltage circuits that are routed through plugs located at the top of the coil frame and behind the fan frame.

Problem	Solution
Erroneous probe readings	Use a light abrasive pad (like Scotch-Brite) to clean the plugs, and a Q-tip to clean the receptacles.

**Defrost Switch:** The defrost switch sends a signal back to the controller indicating the temperature of the coil. The switch is designed to handle high amperages and has a life span of about 100,000 cycles.

Problem	Symptom
Fails Closed	The Defrost Cycle cannot be initiated. Even when the coil is frozen solid
Fails Open	The full 20 minute Defrost Cycle will occur at back request. Even when the blast chiller interior is at room temperature.

A Northwind 500 Model is shown. A Northwind 1000 Model is twice as deep.

