



# KM-350/520/660M\_J(Z)

SLIM-LINE MODULAR CRESCENT CUBER



KM-350/520/660M\_J(Z)  
12/19/24  
Item # 13260

Item #: \_\_\_\_\_  
Project: \_\_\_\_\_  
Qty: \_\_\_\_\_  
AIA#: \_\_\_\_\_

W x D x H  
22" x 27<sup>3/8</sup>" x 28"

**KM|EDGE<sup>™</sup>X**  
ICE MACHINE SERIES

**Air-Cooled**

- KM-350MAJ ★
- KM-520MAJ ★
- KM-660MAJ



Air-cooled model shown on optional bin: B-300

**Water-Cooled**

- KM-350MWJ
- KM-520MWJ
- KM-660MWJ



**Remote Air-Cooled**

- KM-520MRJZ ★
- KM-660MRJZ ★



## Features

- ▶ Individual crescent cube
- ▶ Factory-installed ultrasonic bin control can be adjusted on site
- ▶ Simple, one-hour cleaning process 

- Durable construction with fewer parts
- Self-diagnostic programming automatically adjusts to changing conditions
- Snap fit parts for easy cleaning
- Stainless steel double-sided evaporator
- CycleSaver<sup>™</sup> design 
- EverCheck<sup>™</sup> alert system 
- Removable air filters (air-cooled model only)
- R-404A Refrigerant

**Available on Bins/Dispensers:**

B-250SF	B-500/SF	B-800SF	B-1150SS	DB-130H
B-300SF	B-700SF	B-900SF	B-1300SS	DB-200H
				DM-200B

Top kit may be required. See Bin Spec Sheets.

**Warranty:**

3 Year Parts & Labor on entire machine 5 Year Parts & Labor on evaporator 5 Year Parts on Compressor; air-cooled condenser coil Valid in United States, Canada, Puerto Rico and U.S. Territories. Contact factory for warranty in other countries.

Shipping: (LxWxH) 33.5" x 25.88" X 34.6" Volume: 17.36ft<sup>3</sup>



Condenser	Model	ICE PRODUCTION		WATER USAGE			ELECTRICAL						
		Air / Water Temp Lbs. per 24 hours 70°/50°F	90°/70°F	Potable Gal. per 100 lbs. 90°/70°F	Condenser Gal. per 100 lbs. 90°/70°F	kWh Used per 100 lbs. 90°/70°F	Min. Circuit/Max. Fuse Size	Amperage	Voltage	Circuit Wires (including ground)	Heat Rejection BTU/hr.	Refrigerant Charge Amount	Net / Ship Weight (lbs.)
Air	KM-350MAJ ★	489	393	14.5	N/A	5.42	15A	9.05A	115V/60/1	3	5,700	1 lb. 3.4 oz.	125 / 175
Water	KM-350MWJ	414	383	15.5	109	4.90	15A	7.5A	115V/60/1	3	6,600	11.6 oz.	126 / 175
Air	KM-520MAJ ★	533	450	15.0	N/A	5.25	20A	10.6A	115V/60/1	3	6,600	1 lb. 10.8 oz.	145 / 175
Water	KM-520MWJ	474	444	14.8	75	4.65	20A	8.45A	115V/60/1	3	6,300	12.7 oz.	127 / 175
Remote	KM-520MRJZ ★	547	495	13.6	N/A	4.80	20A	12.05A	115V/60/1	3	6,200	2 lb. 4.7 oz. 4 lb. 2.7 oz. <sup>†</sup>	145 / 175
Air	KM-660MAJ	650	560	14.8	N/A	5.3	20A	15.2A	115V/60/1	3	8,000	1 lb. 9.8 oz.	150 / 180
Water	KM-660MWJ	647	630	16.1	152	4.28	20A	12.35A	115V/60/1	3	8,900	15.2 oz.	130 / 180
Remote	KM-660MRJZ ★	642	570	15.0	N/A	5.25	20A	16.1A	115V/60/1	3	8,100	2 lb. 4.7 oz. 4 lb. 2.7 oz. <sup>†</sup>	150 / 180

<sup>†</sup> (with condenser)

Power cord not included. Must be hard-wired at site.

Hoshizaki reserves the right to change specifications without notice.



# KM-350/520/660M\_J(Z)

KM-350/520/660M\_J(Z)  
12/19/24  
Item # 13260

## SLIM-LINE MODULAR CRESCENT CUBER

### KMEdge™ Cube Dimensions\*

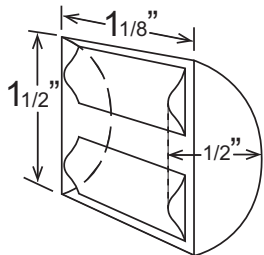

\* approximate size in inches, image not to scale

### Operating Limits

- Ambient Temp Range 45 - 100°F
- Water Temp Range 45 - 90°F
- Water Pressure 10 - 113 PSIG
- Voltage Range 104 - 127V
- If GFCI is required, a GFCI breaker MUST be used in lieu of GFCI receptacle

### Service

- Panels easily removed and all components accessible for service.
- Removable/cleanable air filters. (Air-cooled model only)
- Allow 6" (15 cm) clearance at rear, sides, and top for proper air circulation and ease of maintenance/service.

### Plumbing

- Icemaker water supply line: minimum 1/4" nominal ID copper water tubing or equivalent
- Icemaker drain line: minimum 3/4" nominal ID hard pipe or equivalent Water-Cooled Model (Lines Must Be Independent of Icemaker)
- Condenser water supply line: minimum 1/4" nominal ID copper water tubing or equivalent
- Condenser drain/return line: minimum 1/4" nominal ID hard pipe (open drain system) or copper water tubing (closed loop system) or equivalent

### Water Filter

Please refer to water filter specification sheet for recommendations.

FRONT VIEW

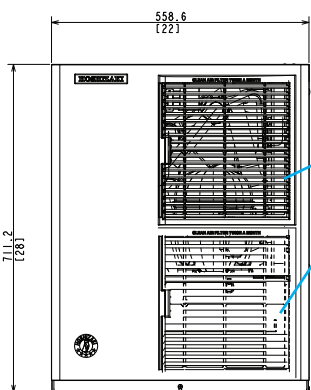

Louvers on Air-Cooled models only

SIDE VIEW

Louvers on Air-Cooled models only

Front →

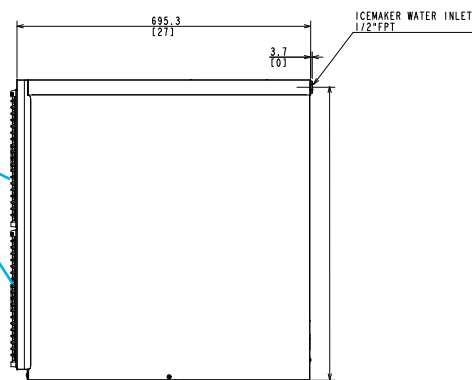

REAR VIEW

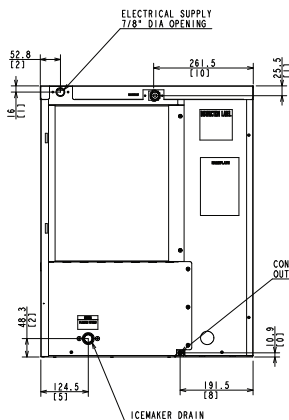

AIR-COOLED

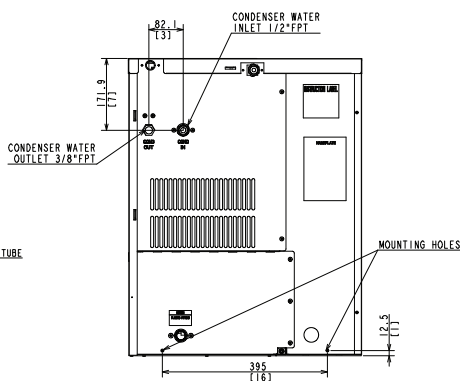

WATER-COOLED

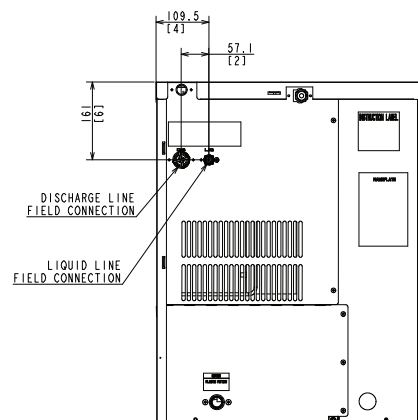

REMOTE AIR-COOLED

BOTTOM VIEW

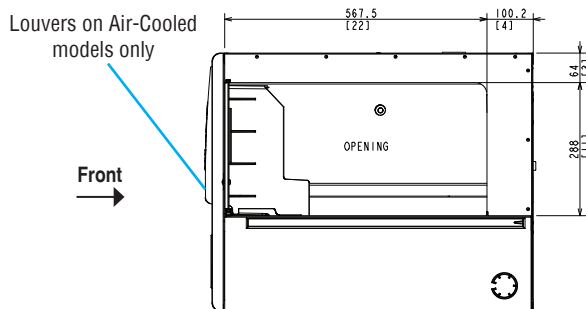

### URC-5FZ Remote Condenser (Sold Separately)

(W x D x H) 21<sup>13/16</sup> x 14<sup>1/16</sup> x 32<sup>13/16</sup>

For Use with KM-520MRJZ and KM-660MRJZ

### Brazed Line Sets (Sold Separately)

25' HS-5587

35' HS-5588

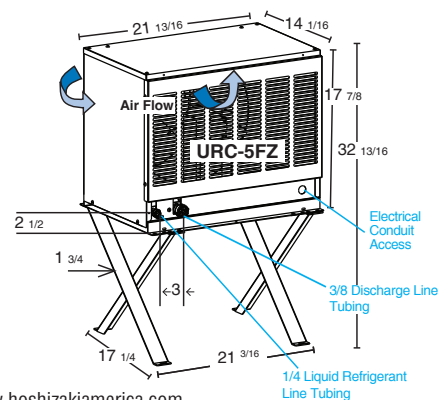



# SF Bins

## ICE STORAGE BIN SERIES



SF Bins  
05/19/25  
Item # 13163

Item #: \_\_\_\_\_  
 Project: \_\_\_\_\_  
 Qty: \_\_\_\_\_  
 AIA#: \_\_\_\_\_

### SF - Stainless Steel Finish

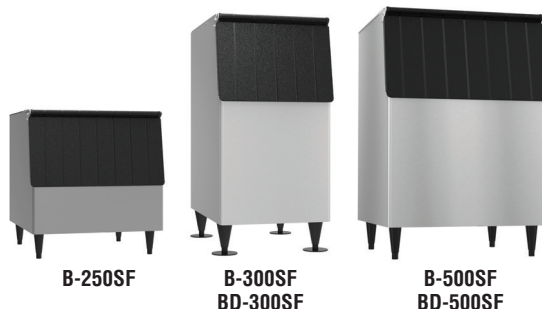

### Features

- ▶ Polyethylene bin liner for sanitary storage
- ▶ Sturdy construction for side-by-side or stacked ice machine installation

- Ice storage capacity from 250 lbs. up to 900 lbs.
- Both surfaces are designed for easy cleaning
- Long lasting attractive appearance
- Foamed-in-place polyurethane insulation, in all bin walls and bottom, provides dependable ice storage

### SF - Stainless Steel Finish

#### BD Bins

- Fit 24" - 24 1/2" deep ice machine without top kit extension

#### Warranty:

2 Year Parts & Labor (Production prior to January 2012)  
 3 Year Parts & Labor (Production January 2012 and after)  
 Valid in United States, Canada, Puerto Rico and U.S. Territories. Contact factory for warranty in other countries.



Model Number	Exterior Dimensions W x D x H*	Interior Dimensions W x D x H	Application Storage Capacity †	Cubic Volume	Shipping Dimensions L x W x H	Shipping Weight (lbs.)
B-250SF	30" x 32.3" x 33.4"	27" x 27.7" x 23.7"	250 lbs.	10.30 ft <sup>3</sup>	35" x 32" x 32"	—
B-300SF	22" x 32.3" x 46"	19" x 27.7" x 37.6"	300 lbs.	11.51 ft <sup>3</sup>	35" x 24" x 45"	125
BD-300SF	22" x 32.3" x 46"	19" x 27.7" x 37.6"	300 lbs.	11.51 ft <sup>3</sup>	35" x 24" x 45"	130
B-500SF	30" x 32.3" x 46"	27" x 27.7" x 37.6"	500 lbs.	16.33 ft <sup>3</sup>	35" x 32" x 45"	140
BD-500SF	30" x 32.3" x 46"	27" x 27.7" x 37.6"	500 lbs.	16.33 ft <sup>3</sup>	35" x 32" x 45"	140
B-700SF	44" x 32.3" x 46"	41" x 27.7" x 37.6"	700 lbs.	24.77 ft <sup>3</sup>	46" x 35" x 45"	175
B-800SF	48" x 32.3" x 46"	45" x 27.7" x 37.6"	800 lbs.	26.90 ft <sup>3</sup>	50.25" x 35" x 45"	185
B-900SF	52" x 32.3" x 46"	49" x 27.7" x 37.6"	900 lbs.	29.59 ft <sup>3</sup>	54.5" x 35" x 45"	195

\*Height includes 6" legs

† Capacity based on volume x 30 lb/ft<sup>3</sup> average density of ice.

Hoshizaki reserves the right to change specifications without notice.



# SF Bins

## ICE STORAGE BIN SERIES



SF Bins  
05/19/25  
Item # 13163

### Ice Machine Model Application

	22" Width	22" Width	30" Width	30" Width	44" Width	44" Width	48" Width
	KM-350M KM-520M KM-660M F-450M F-801M F-1002M	KMD-410M† KMS-822M FD-650M-C† FD-1002M-C	KM-901M KM-1100M KM-1340M KM-1601M KML Series F-1501M F-2001	KMD-355M KMD-505M KMD-705M KMD-460M‡ KMD-530M‡ KMD-860M‡ KMS-1402M* KMS-2000M*	2 KM-350M 2 KM-520M 2 KM-660M IM-500S 2 F-450M 2 F-801M 2 F-1002M	2 KMD-410M 2 FD-650M-C 2 FD-1002M-C	KM-1301S KM-1400S KM-1601S KM-1900S KM-2200S KM-2600S
<b>Bins</b> B-300SF DB-130H	—	NEED HS-2153 <i>(KMD-410 on B-300 only)</i> <i>(KMD-410 not compatible with DB-130H)</i>	N/A	N/A	N/A	N/A	N/A
<b>Bins</b> B-250SF B-500SF	NEED HS-2033	NEED HS-2033 & HS-2129	—	NEED HS-2129	N/A	N/A	N/A
<b>Bins</b> B-700SF	NEED HS-2035	NEED HS-2035 & HS-2130	NEED HS-2034	NEED HS-2130 & HS-2034	—	NEED HS-2130 <i>(KMD-410 does not apply)</i>	N/A
<b>Bins</b> B-800SF	NEED HS-2035 & HS-2032	NEED HS-2035, HS-2032 & HS-2131	NEED HS-2034 & HS-2032	NEED HS-2131, HS-2034 & HS-2032	NEED HS-2032	NEED HS-2032 & HS-2131	—
<b>Bins</b> B-900SF	NEED HS-2035 & HS-2033	NEED HS-2035, HS-2033 & HS-2132	NEED HS-2035	NEED HS-2132 & HS-2035	NEED HS-2033	NEED HS-2033 & HS-2132	NEED HS-2032
<b>Bins</b> DB-200H DM-200B	NEED HS-2036 <i>(KM units only)</i>	N/A	— <i>(KML Series only)</i>	NEED HS-2148 <i>(KMD Series on DB-200H only)</i>	N/A	N/A	N/A

— No top kit necessary | N/A Combination of ice maker and bin is not possible

**BD Bins fit 24" - 24 1/2" deep ice machine without Top Kit extension.**

† **BD-300SF:** KMD-410M, KMS-822M, FD-650M-C, FD-1002M-C

‡ **BD-500SF:** KMD-460M, KMD-530M, KMD-860M, KMD-355, KMD-505M, KMD-705M

#### Top Kits:

- HS-2032 - 4" ABS Top Kit
- HS-2033 - 8" ABS Top Kit
- HS-2034 - 14" ABS Top Kit
- HS-2035 - 22" ABS Top Kit
- HS-2036 - (2) 4" ABS Top Kits
- HS-2066 - Seismic Kit for SD 500 Stands
- HS-2071 - Anchored Leg Kit SD 500 Stands
- HS-2111 - 11.3" x 26.2" Stainless Cover/Separator
- HS-2148 - 30" x 3.1" Stainless Cover
- HS-2153 - KMD-410 on B-300 bin
- HS-2160 - (2) KM-901M / (2) KM-1100M

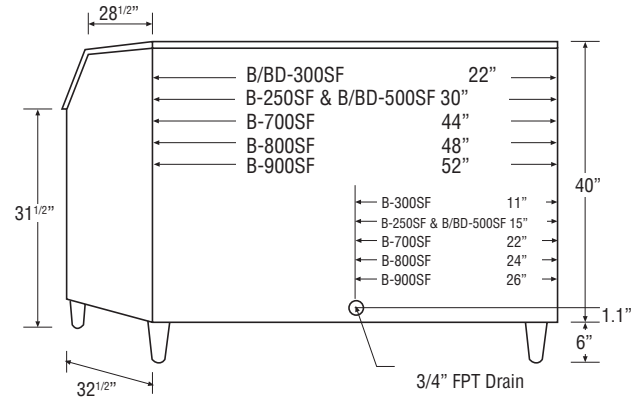

### Ice Drop Area



**B Bins**



**BD Bins**



**Bin Flanged Legs:**  
B/BD-300SF



**Bin Legs:**  
B-250SF, B/BD-500SF  
B-700SF, B-800SF  
B-900SF