



F-622MAK-C

Modular Cubelet Ice Machine
Slim-Line Dispenser Series



F-622MAK-C
10/01/25
Item # 13742

W x D x H
22¹/₈" x 24¹/₄" x 25⁷/₈"

F-622MAK-C ★
Air-Cooled



Features

- ▶ Durable stainless steel exterior
- ▶ Factory-installed ultrasonic bin control can be adjusted on site
- ▶ Environmentally friendly R290 hydrocarbon refrigerant

- Stainless steel auger with greaseless bearing
- Up to 640 lbs. of ice production per 24 hours
- 2 second flush cycle every hour
- Flush cycle removes sediment for cleaner ice
- Advanced CleanCycle24™ 
- Durable stainless steel exterior

Available on Bins:

B-250SF B-500SF B-700SF B-800SF B-900SF B-1300SS
B-300SF B-700SF B-800SF B-900SF B-1150SS

Warranty:

3 Year Parts & Labor on entire machine. 5 Year Parts on Compressor; air-cooled condenser coil. Valid in United States, Canada, Puerto Rico and U.S. Territories. Contact factory for warranty in other countries.

Shipping: (LxWxH) 28.5" x 26.75" x 32" Volume: 14.12ft³

Condenser	Model	ICE PRODUCTION		WATER USAGE		ELECTRICAL					Refrigerant Charge Amount	Net / Ship Weight (lbs.)	
		Air / Water Temp Lbs. per 24 hours 70°/50°F 90°/70°F	Potable Gal. per 100 lbs. 90°/70°F	Condenser Gal. per 100 lbs. 90°/70°F	kWh Used per 100 lbs. 90°/70°F	Min. Circuit/Max. Fuse Size	Amperage	Voltage	Circuit Wires (including ground)	Heat Rejection BTU/hr.			
Air	F-622MAK-C	640	500	12.0	N/A	4.55	20A	8.9A	115V/60/1	3	6,000	4.1 oz.	176 / 185

Cube Dimensions*

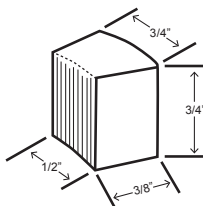

* approximate size in inches, image not to scale

Operating Limits

- Ambient Temp Range 45 - 100°F
- Water Temp Range 45 - 90°F
- Water Pressure 10 - 113 PSIG
- Voltage Range 108-127V
- If GFCI is required, a GFCI breaker MUST be used in lieu of GFCI receptacle

Service

- Panels easily removed and all components accessible for service.
- Allow 24" (61 cm) clearance at top for removal of auger and 6" (15 cm) clearance at rear and sides for proper air circulation and ease of maintenance/service.

Plumbing

- Icemaker Water Supply Line: Minimum 1/4" Nominal ID Copper Water Tubing or Equivalent
- Icemaker Drain Line: Minimum 3/4" Nominal ID Hard Pipe or Equivalent
- Water-Cooled Model (Lines Must Be Independent of Icemaker)
- Condenser Water Supply Line: Minimum 1/4" Nominal ID Copper Water Tubing or Equivalent
- Condenser Drain/Return Line: Minimum 1/4" Nominal ID Hard Pipe (open drain system) or Copper Water Tubing (closed loop system) or Equivalent

Hoshizaki reserves the right to change specifications without notice.



F-622MAK-C

Modular Cubelet Ice Machine
Slim-Line Dispenser Series

F-622MAK-C
10/01/25
Item # 13742

FRONT VIEW

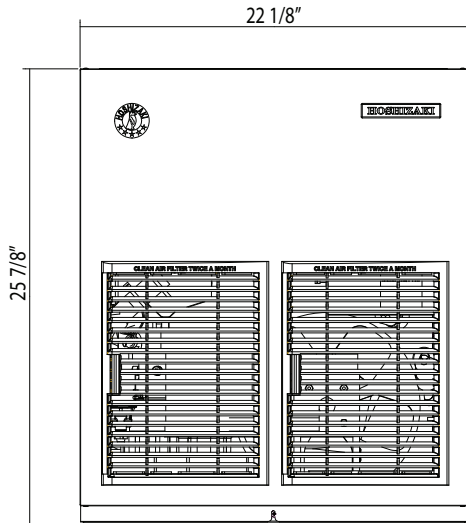

SIDE VIEW

inch
[mm]

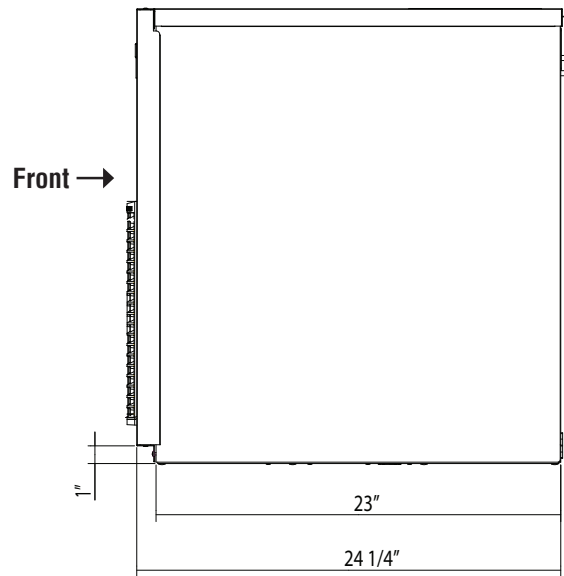

REAR VIEW

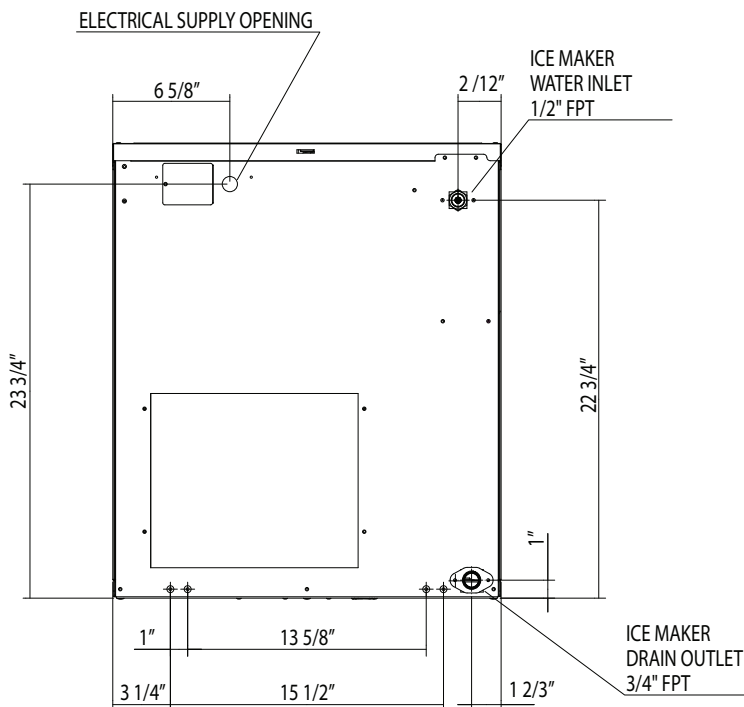

BOTTOM VIEW

