

INSTALLATION INSTRUCTIONS
BUILT-IN DRAWER WARMERS
RW-16 (T, HD)

ELECTRICAL

| MODEL | VOLTS | WATTS | AMPS | PHASE | FIELD WIRING GAUGE | TEMP. RATING |
|-------|-------|-------|------|--------|--------------------|--------------|
| RW-16 | 120 | 450 | 3.8 | SINGLE | 14 AWB Cu | 90°C |
| RW-16 | 208 | 338 | 1.6 | SINGLE | 14 AWB Cu | 90°C |
| RW-16 | 240 | 450 | 1.9 | SINGLE | 14 AWB Cu | 90°C |

INCHES
(MM)

RW-16HD, RWT-16/16HD MODELS HAVE THE SAME ELECTRICAL SPECIFICATIONS AS THE STANDARD UNITS

CUTOUT DETAILS

PRODUCT DIMENSIONS

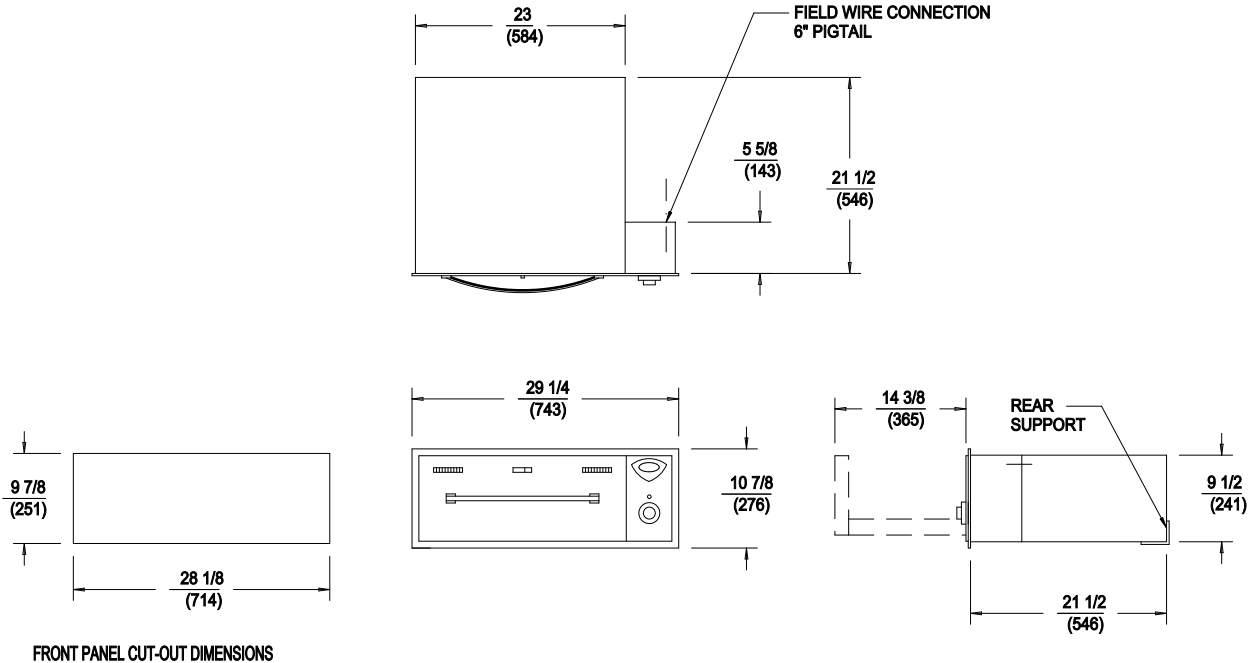

FRONT PANEL CUT-OUT DIMENSIONS

INSTALLATION INSTRUCTIONS

INSTALLER MUST MEET CONDITIONS OF ACCEPTABILITY OUTLINED BELOW UPON INSTALLATION:

TO FABRICATE:

1. Layout front panel cutout dimensions and cutout hole in counter front panel.
2. Position attaching flange (supplied) in hole cutout to determine screw hole location. Drill holes using #34 drill.
3. Attach flange to front panel using #6 screws provided.
4. Fabricate rails and rear support in locations shown.

TO INSTALL:

1. For ease of installation, remove drawer from unit.
2. Slide unit through front panel opening until rear of unit engages rear support.
3. Remove control knob and control panel.
4. Install #8-32 speednuts on attaching flange, secure attaching flange to front panel, then secure unit to attaching flange using #8-32 flathead screws provided.
5. Connect service leads to the unit including ground wire.
6. Replace control panel and control knob.
7. Replace drawer.

