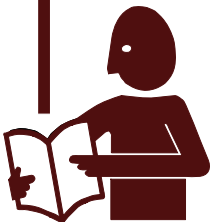

**WELLS MANUFACTURING**

10 Sunnen Dr., St. Louis, MO 63143

telephone: 314-678-6314

fax: 314-781-2714

www.wellsbloomfield.com**OWNERS MANUAL
for
COUNTERTOP
CERAMIC
HOTPLATES****Models:****HC100****HC125****HC225***Model HC225***Includes
INSTALLATION
USE & CARE
EXPLODED VIEW
PARTS LIST
WIRING DIAGRAM****IMPORTANT: DO NOT DISCARD THIS MANUAL**

This manual is considered to be part of the appliance and is to be given to the OWNER or MANAGER of the restaurant, or to the person responsible for TRAINING OPERATORS of this appliance. Additional manuals are available from your WELLS DEALER.

THIS MANUAL MUST BE READ AND UNDERSTOOD BY ALL PERSONS USING OR INSTALLING THIS APPLIANCE. Contact your WELLS DEALER if you have any questions concerning installation, operation or maintenance of this equipment.

LIMITED WARRANTY STATEMENT

Unless otherwise specified, all commercial cooking equipment manufactured by WELLS MANUFACTURING is warranted against defects in materials and workmanship for a period of one year from the date of original installation or 18 months from the date of shipment from our factory, whichever comes first, and is for the benefit of the original purchaser only.

THIS WARRANTY IS THE COMPLETE AND ONLY WARRANTY, EXPRESSED OR IMPLIED IN LAW OR IN FACT, INCLUDING BUT NOT LIMITED TO, WARRANTIES OF MERCHANTABILITY OR FITNESS FOR ANY PARTICULAR PURPOSE, AND/OR FOR DIRECT, INDIRECT OR CONSEQUENTIAL DAMAGES IN CONNECTION WITH WELLS PRODUCTS. This warranty is void if it is determined that, upon inspection by an authorized service agency, the equipment has been modified, misused, misapplied, improperly installed, or damaged in transit or by fire, flood or act of God. It also does not apply if the serial nameplate has been removed, or if service is performed by unauthorized personnel. The

prices charged by Wells Manufacturing for its products are based upon the limitations in this warranty. Seller's obligation under this warranty is limited to the repair of defects without charge by a Wells Manufacturing factory authorized service agency or one of its sub-service agencies. This service will be provided on customer's premises for non-portable models. Portable models (a device with a cord and plug) must be taken or shipped to the closest authorized service agency, transportation charges prepaid, for service. In addition to restrictions contained in this warranty, specific limitations are shown in the Service Policy and Procedure Guide. Wells Manufacturing authorized service agencies are located in principal cities. This warranty is valid in the United States and Canada and void elsewhere. Please consult your classified telephone directory, your foodservice equipment dealer or contact:

Wells Manufacturing
10 Sunnen Dr., St. Louis MO 63143 USA
phone (314) 678-6314 or fax (314) 781-2714

for information and other details concerning warranty.

SERVICE POLICY AND PROCEDURE GUIDE and ADDITIONAL WARRANTY EXCLUSIONS

1. Resetting of safety thermostats, circuit breakers, over load protectors, and/or fuse replacements are not covered by this warranty unless warranted conditions are the cause.
2. All problems due to operation at voltages or phase other than specified on equipment nameplates are not covered by this warranty. Conversion to correct voltage and/or phase must be the customer's responsibility.
3. All problems due to electrical connections not made in accordance with electrical code requirements and wiring diagrams supplied with the equipment are not covered by this warranty.
4. Replacement of items subject to normal wear, to include such items as knobs, light bulbs; and, normal maintenance functions including adjustments of thermostats, adjustment of micro switches and replacement of fuses and indicating lights are not covered by warranty.
5. Damage to electrical cords and/or plug due to exposure to excessive heat are not covered by this warranty.
6. Full use, care, and maintenance instructions supplied with each machine. Noted maintenance and preventative maintenance items, such as servicing and cleaning schedules, are customer responsibility.
7. Those miscellaneous adjustments noted are customer responsibility. Proper attention to preventative maintenance and scheduled maintenance procedures will prolong the life of the appliance.
8. Travel mileage is limited to sixty (60) miles from an Authorized Service Agency or one of its sub-service agencies.
9. All labor shall be performed during regular working hours. Overtime premium will be charged to the buyer.
10. All genuine Wells replacement parts are warranted for ninety (90) days from date of purchase on non-warranty equipment. This parts warranty is limited only to replacement of the defective part(s). Any use of non-genuine Wells parts completely voids any warranty.
11. Installation, labor, and job check-outs are not considered warranty and are thus not covered by this warranty.
12. Charges incurred by delays, waiting time or operating restrictions that hinder the service technician's ability to perform service are not covered by warranty. This includes institutional and correctional facilities.

SHIPPING DAMAGE CLAIM PROCEDURE

NOTE: For your protection, please note that equipment in this shipment was carefully inspected and packaged by skilled personnel before leaving the factory. Upon acceptance of this shipment, the transportation company assumes full responsibility for its safe delivery.

IF SHIPMENT ARRIVES DAMAGED:

1. **VISIBLE LOSS OR DAMAGE:** Be certain that any visible loss or damage is noted on the freight bill or express receipt, and that the note of loss or damage is signed by the delivery person.
2. **FILE CLAIM FOR DAMAGE IMMEDIATELY:** Regardless of the extent of the damage.
3. **CONCEALED LOSS OR DAMAGE:** if damage is unnoticed until the merchandise is unpacked, notify the transportation company or carrier immediately, and file "CONCEALED DAMAGE" claim with them. This should be done within fifteen (15) days from the date the delivery was made to you. Be sure to retain the container for inspection.

Wells Manufacturing cannot assume liability for damage or loss incurred in transit. We will, however, at your request, supply you with the necessary documents to support your claim.

TABLE OF CONTENTS

WARRANTY	xi	Thank You for purchasing this Wells Manufacturing appliance
SPECIFICATIONS	1	
FEATURES & OPERATING CONTROLS	2	Proper installation, professional operation and consistent maintenance of this equipment will ensure that it gives you the very best performance and a long, economical service life.
PRECAUTIONS & GENERAL INFORMATION	3	
INSTALLATION	4	
OPERATION	5	
CLEANING INSTRUCTIONS	6	This manual contains the information needed to properly install this equipment, and to use and care for the equipment in a manner which will ensure its optimum performance.
SPECIAL CARE INSTRUCTIONS	7	
TROUBLESHOOTING	8	
EXPLODED VIEW & PARTS LIST	9-14	
WIRING DIAGRAM	15-16	
PARTS & SERVICE	21	
CUSTOMER SERVICE DATA	21	

SPECIFICATIONS

MODEL	ELEMENT	WIDTH	DEPTH	VOLTS	AMPS	kW	PLUG	LEG HEIGHT
HC100	Single 7"	12-5/8"	12-5/8"	120 V	11.7 A	1.4 kW	NEMA 5-15P	1"
HC125	Single 9"	14-3/4"	14"	208 V 1 \emptyset	9.0 A	1.9 kW	NEMA 6-15P	1"
				240 V 1 \emptyset	10.4 A	2.5 kW	NEMA 6-15P	1"
HC225	Dual 9"	14-3/4"	24-5/8"	208 V 1 \emptyset	18.1 A	3.8 kW	NEMA 6-30P	1"
				240 V 1 \emptyset	20.8 A	5.0 kW	NEMA 6-30P	1"

SPECIFICATIONS - EXPORT MODELS

MODEL	ELEMENT	WIDTH	DEPTH	VOLTS	AMPS	kW	LEGS
HC125EU	Single 9"	14-3/4"	14"	220-240V 1 \emptyset	10.4 A	2.5 kW	1"
HC225EU	Dual 9"	14-3/4"	24-5/8"	220-240V 1 \emptyset	20.8 A	5.0 kW	1"

Refer to the Export Manual for this equipment (p/n 2M-301399) for specific  information.

FEATURES & OPERATING CONTROLS

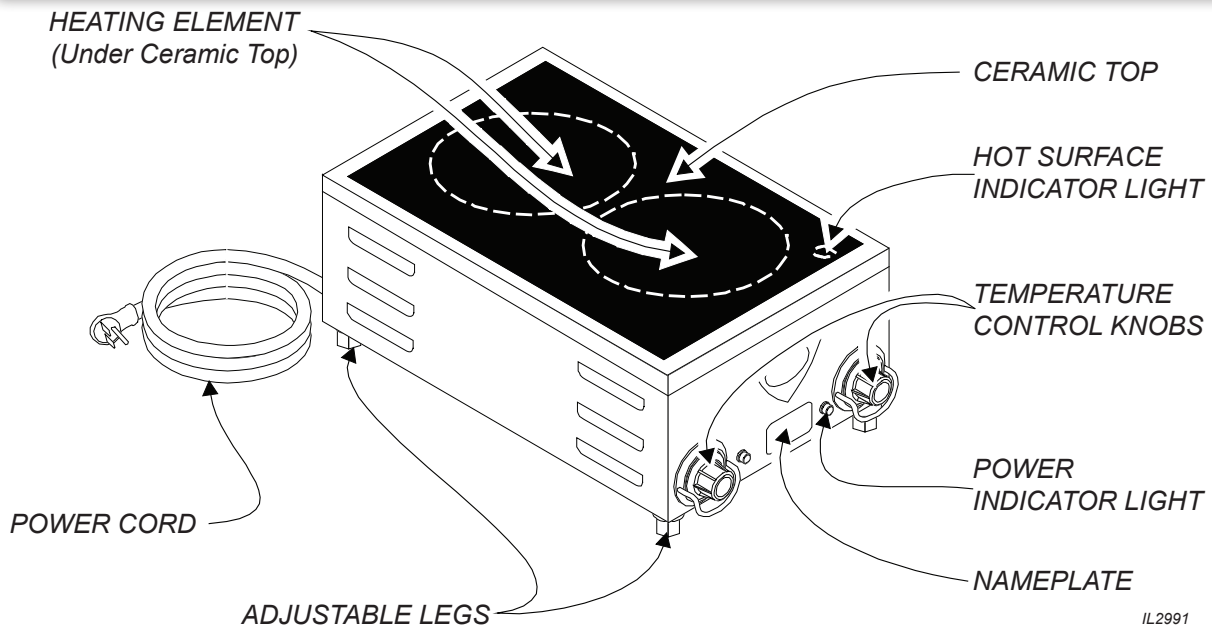

Ceramic Top	Provides smooth, low maintenance heating surface
Heating Element	Provides heat for food preparation Note: elements located under ceramic top
Hot Surface Indicator Light	Glowes whenever ceramic top is above 150°F (66°C)
Temperature Control	Infinite switch to control temperature of heating element
Power Indicator Light	Glowes any time temperature control is on
Name Plate	Lists manufacturer, model number and serial number Also lists voltage and wattage rating
Power Cord	Connects hotplate to electrical power
Adjustable Legs	Provides ventilation under hotplate Allow hotplate to be leveled

PRECAUTIONS AND GENERAL INFORMATION

This appliance is intended for use in commercial establishments only.

This appliance is intended to prepare food for human consumption. No other use is recommended or authorized by the manufacturer or its agents.

Operators of this appliance must be familiar with the appliance use, limitations and associated restrictions. Operating instructions must be read and understood by all persons using or installing this appliance.

Cleanliness of this appliance is essential to good sanitation. Read and follow all included cleaning instructions and schedules to ensure the safety of the food product.

Disconnect the hotplate from electrical power before performing any maintenance or servicing.

DO NOT submerge hotplate in water. DO NOT splash or pour water over, onto or into controls or wiring.

Hotplate must be operated with the supplied legs properly installed.

The technical content of this manual, including any wiring diagrams, schematics, parts breakdown illustrations and/or adjustment procedures, is intended for use by qualified technical personnel.

Any procedure which requires the use of tools must be performed by a qualified technician.

This manual is considered to be a permanent part of the appliance. This manual and all supplied instructions, diagrams, schematics, parts breakdown illustrations, notices and labels must remain with the appliance if it is sold or moved to another location.

This appliance is made in the USA. Unless otherwise noted, this appliance has American sizes on all hardware. This unit complies with NSF Standard 4 only if maintained and operated per the instructions in this manual.



WARNING: ELECTRIC SHOCK HAZARD

All servicing requiring access to non-insulated electrical components must be performed by a factory authorized technician.

DO NOT open any access panel that requires the use of tools. Failure to follow this warning can result in severe electrical shock.



CAUTION: RISK OF DAMAGE

DO NOT connect and/or energize this appliance until all installation instructions are read and followed. Damage to the appliance will result if these instructions are not followed.

AGENCY APPROVAL INFORMATION

This unit is  listed under E6070.

Export versions (only) of this unit meet  standards.



STD 4



E6070



E6070



EXPORT
MODELS
ONLY

INSTALLATION

NOTE: DO NOT discard the carton or other packing materials until you have inspected the appliance for hidden damage and tested it for proper operation. Refer to SHIPPING DAMAGE CLAIM PROCEDURE on the inside front cover of this manual.



CAUTION: ELECTRIC SHOCK HAZARD

The ground prong of the power cord is part of a system designed to protect you from electric shock in the event of internal damage to the appliance.

NEVER CUT OFF THE GROUND PRONG (large round prong). **NEVER TWIST A PRONG TO FIT AN EXISTING RECEPTACLE.**

Contact a licensed electrician to install an electrical receptacle appropriate to the voltage and amperage requirements of the hotplate.

IMPORTANT:

Damage due to being plugged into the wrong voltage or phase is NOT covered by warranty

UNPACKING & INSPECTION

Carefully remove the hotplate from the carton. Remove all protective plastic film, packing materials and accessories from the hotplate before plugging the hotplate into electrical power or otherwise performing any installation procedure.

Carefully read all instructions in this manual and the Installation Instruction Sheet packed with the hotplate before starting any installation.

Read and understand all labels and diagrams attached to the hotplate.

Carefully account for all components and accessories before discarding packing materials. Store all accessories in a convenient place for later use.

SETUP

Supplied legs must be properly installed.

Setup the hotplate only on a firm level surface. Non-combustible material (e.g. metal, terrazzo) is recommended.

Maintain at least 1" from adjacent surfaces.

ELECTRICAL

Refer to the nameplate. Verify the electrical service power. Voltage and phase must match the nameplate specifications. Connecting the hotplate to the wrong voltage can severely damage the equipment or cause noticeably decreased performance.

Hotplate is equipped with a grounded electric power cord, this cord must be plugged into a properly grounded electrical receptacle.

GENERAL OPERATIONAL NOTES

Carefully read the description of the hotplate operation on the specification sheet.

DO NOT attempt to perform any maintenance or service unless the hotplate is unplugged or disconnected from electrical power.

DO unplug the hotplate from electrical power or turn the circuit breaker off before cleaning or servicing.

DO NOT use steel wool or abrasive cleansers to clean the ceramic top.

DO use the supplied scraper to remove burned-on food product.

OPERATION

Each heating element is controlled by an infinite switch temperature control:

OFF removes power from the element

LOW thru 8 are temperature settings

Higher numbers indicate higher temperatures

There is a continuous range of settings between LOW and HI

HI is a continuous ON setting

The power indicator light will glow any time the temperature control is on.

The hot surface indicator light will glow any time the ceramic surface is approximately 150°F (65°C) or higher.

Cooking Recommendations:

Save energy by turning the temperature control off any time the hotplate is not in use. The heating elements will provide full heat within 30 seconds, making it unnecessary to leave the unit on during intermittent use.

Each heating element can hold up to a 16 quart pot or pan. For efficient heating of food product, pots and pans should be no more than 10" in diameter. Maximize the efficiency of the ceramic top by using flat-bottom pots and pans.

Preserve the luster of the ceramic cook surface by wiping up spills promptly and by cleaning frequently. Allow the hotplate to cool completely before cleaning. Use only cook-top cleaning crème on glass-ceramic cooking surfaces.

Stir thick liquids frequently to maintain a consistent temperature.



**CAUTION:
HOT SURFACES**

Exposed surface can be hot to the touch and may cause burns.



**CAUTION:
HOT SURFACES**

Ceramic cooking surfaces are hot anytime the HOT SURFACE indicator light is lit.

DO NOT touch the cooking surface if the HOT SURFACE light is lit.

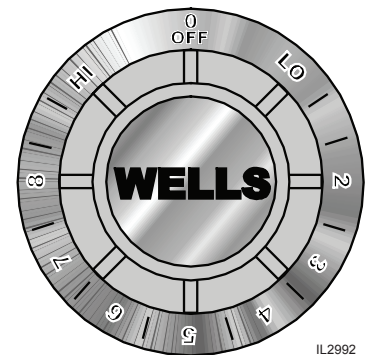

IMPORTANT:

The dial markings are an INDICATION of temperature only. The temperature of the food product depends on many factors, including the size, shape and material of the food container, and the quantity and consistency of the food product.

CLEANING INSTRUCTIONS



CAUTION: ELECTRIC SHOCK HAZARD

Unplug hotplate from electric power before cleaning.



CAUTION: BURN HAZARD

Allow hotplate to cool completely before cleaning.



CAUTION: ELECTRIC SHOCK HAZARD

Do not submerge hotplate in water.

IMPORTANT: DO NOT spill or pour water into controls, control panel or wiring.

DO NOT submerge hotplate in water. Damage to internal components will occur. Damage to internal components from water damage is NOT covered by warranty.

DO NOT steel wool or metal scouring pads to clean ceramic heating surface.

PREPARATION

Unplug or disconnect hotplate from electrical power before cleaning. Allow hotplate to cool completely before cleaning.

FREQUENCY

Daily

TOOLS

Cleaning Creme
Razor Scraper
Clean Cloth or Sponge
Mild Detergent or Cleaner Formulated for Stainless Steel
Warm Water

CLEANING

Unplug or disconnect hotplate from electrical power before cleaning.

Allow the hotplate to cool until the HOT SURFACE indicator light goes off before cleaning.

Clean food particles from the ceramic cooking surface with a razor scraper. Hold the edge of blade flat against the surface and at a 15° angle to avoid scratching the ceramic. DO NOT use metal implements (other than the razor scraper), steel wool or metal scouring pads to clean the ceramic cooking surface.

Use only cook-top cleaning creme on glass-ceramic cooking surfaces. Wipe the ceramic cooking surfaces with cleaning creme and a clean cloth. The cleaning creme leaves a protective coating.

Wipe the outer portions of the hotplate cabinet with a clean soft cloth or sponge dampened with warm water and a mild detergent or cleaner formulated for cleaning stainless steel. DO NOT use steel wool to clean hotplate cabinet.

Rinse by wiping hotplate cabinet with a clean soft cloth or sponge moistened with clean warm water. Dry cabinet by wiping with a clean soft dry cloth.

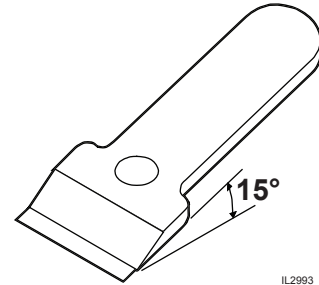

SPECIAL CARE INSTRUCTIONS

DO NOT use the hotplate surface as a cutting board.

DO NOT cook directly on the glass-ceramic surface.

Check glass and ceramic cookware to verify suitability for use on hotplates.

DO NOT drop cookware onto glass-ceramic cook surface.

Carefully place heavy pots and skillets on glass-ceramic cook surface to avoid damage.

Avoid sliding cookware across hotplate surface.

Remove stains and metal marks from the glass-ceramic cook surface after use by cleaning with cleaning creme. Allow hotplate surface to cool completely before cleaning

DO NOT leave empty cookware on a hot cooking surface.

Avoid contacting the hot glass-ceramic surface with plastic or aluminum foil, which may melt.



CAUTION: BURN HAZARD

Allow hotplate to cool completely before cleaning.



CAUTION: CUT HAZARD

DO NOT attempt to cook on a broken hotplate surface. Severe injury may result. Contact an Authorized Wells Service Agency immediately for repairs.



CAUTION: CUT HAZARD

DO NOT attempt to repair a broken hotplate surface. The glass-ceramic surface is impossible to repair successfully. A broken surface can cause severe injury. Contact an Authorized Wells Service Agency immediately for repairs.

TROUBLESHOOTING

SYMPTOM	POSSIBLE CAUSE	SUGGESTED REMEDY
Hotplate won't heat	Not plugged in, damaged plug or cord or circuit breaker tripped	Check plug and cord
		Check / reset circuit breaker
One or more sections won't heat	Temperature control not on	Turn temperature control to desired setting
	Damaged temperature control, element or other internal component	Contact Authorized Wells Service Agency for repairs
Hotplate not hot enough	Temperature control not set	Adjust for desired temperature
	Operating 208/240V unit at 120V	Be sure supply voltage matches nameplate voltage
	Damaged temperature control, element or other internal component	Contact Authorized Wells Service Agency for repairs
Hot surface indicator does not light, or stays on	Damaged temperature control, element or other internal component	Contact Authorized Wells Service Agency for repairs

NOTE: There are no user serviceable components in this appliance. In all cases of damage or component malfunction, contact your Authorized Wells Service Agency for repairs.

EXPLODED VIEW: HC100

HC-100 COUNTERTOP ELECTRIC CERAMIC HOTPLATE

22328 HC100 COUNTERTOP CERAMIC HOTPLATE 120VAC

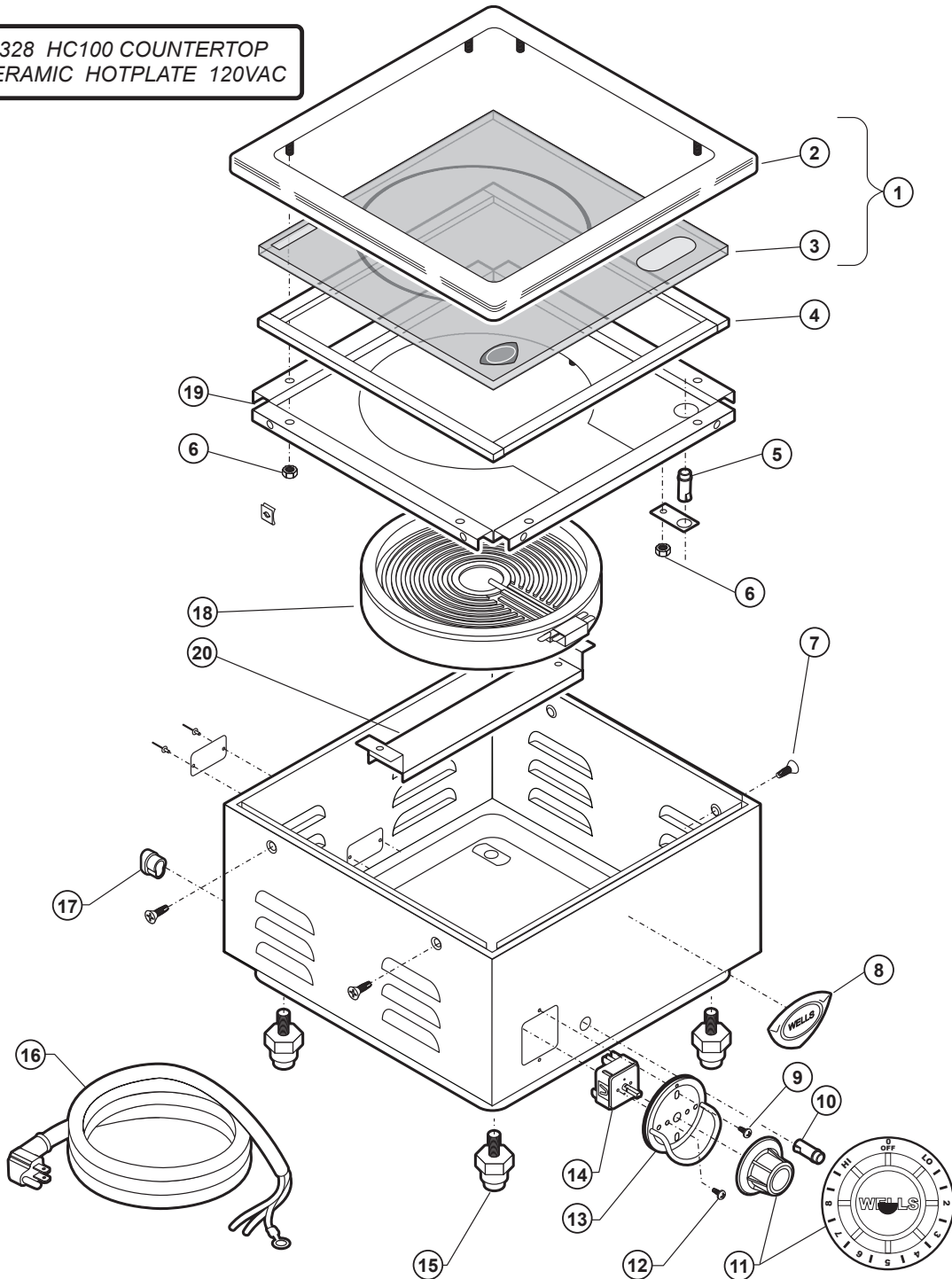

Model: HC100
Countertop Electric Ceramic Hotplate

PL223



IL1814 Rev. B 3/20/14

223 p/n 2M-303755 Owners Manual Counter Top Ceramic Hotplates

PARTS LIST: HC100

HC100 COUNTERTOP ELECTRIC CERAMIC			
Fig No	Part No	Qty	Description
1	WS-501686	1	TOP ASSY HC-100 120V
2	I7-301686	1	TOP ASSY
3	2Q-301661	1	GLASS CERAMIC HC100
4	2H-301213	6FT	INSUL LYTHERM HP 1/4X5/8
5	2J-301121	1	LIGHT SIGNAL CLEAR 120V
6	2C-31053	11	NUT 8-32 KEPS MS NICKEL
7	2C-34285	4	SCREW 8-32X3/8 PH 100 FL
8	2M-300534	1	TRADEMARK DOMED LABEL
9	2C-33935	2	SCREW 6ABX5/16 PH PAN SMS
10	2J-70309	1	LIGHT PILOT RED 125V 1/3W
11	2R-30371	1	KNOB ASSY WARMERS
12	2C-31697	2	SCREW 8-32X3/16 PH RD HD
13	D8-30256	1	TRIM RING ASSY
14	2E-30570	1	SWITCH INFINITE 120V A
15	2A-41946	4	LEG ADJUST 1IN
16	2E-70017	1	CORD SET 6FT 5-15P
17	2K-70215	1	STRAIN RELIEF STR
18	2N-301660	1	ELEM HC100 120V 1400W
19	I7-301664	1	RETAINER ELEMENT HC-100

HC-125 COUNTERTOP ELECTRIC CERAMIC			
Fig No	Part No	Qty	Description
1	WS-501649	1	TOP ASSY REPLACEMENT HC-125
2	I7-301214	1	TOP DRAWN HC-125 1256
3	WS-501109	1	GLASS CERAMIC HC-125 1256
4	2H-301213	6FT	INSUL LYTHERM HP 1/4X5/8
5	2J-301121	1	LIGHT SIGNAL CLEAR 120V
6	2C-31053	11	NUT 8-32 KEPS MS NICKEL
7	2N-301120	1	ELEM 240V 2500W HC-125
8	2M-300534	1	TRADEMARK DOMED LABEL
9	2C-33935	2	SCREW 6ABX5/16 PH PAN SMS
10	2J-31157	1	LIGHT SIGNAL RED
11	2R-30371	1	KNOB ASSY WARMERS
12	2C-31697	2	SCREW 8-32X3/16 PH RD HD
13	D8-30256	1	TRIM RING ASSY
14	2E-30562	1	SWITCH INFINITE 240V A
15	2A-41946	4	LEG ADJUST 1IN
16	2E-35540	1	CORD SET 6-15P 16/3W 4FT
17	2C-34285	4	SCREW 8-32X3/8 PH
18	2K-70215	1	STRAIN RELIEF STR HEYCO
19	I7-301144	1	RETAINER ELEMENT HC-125
20	I7-301119	1	BRKT ELEMENT HC-125

EXPLODED VIEW: HC225

HC-225 COUNTERTOP ELECTRIC CERAMIC HOTPLATE

22307 HC-225 COUNTERTOP CERAMIC HOTPLATE
208/240VAC

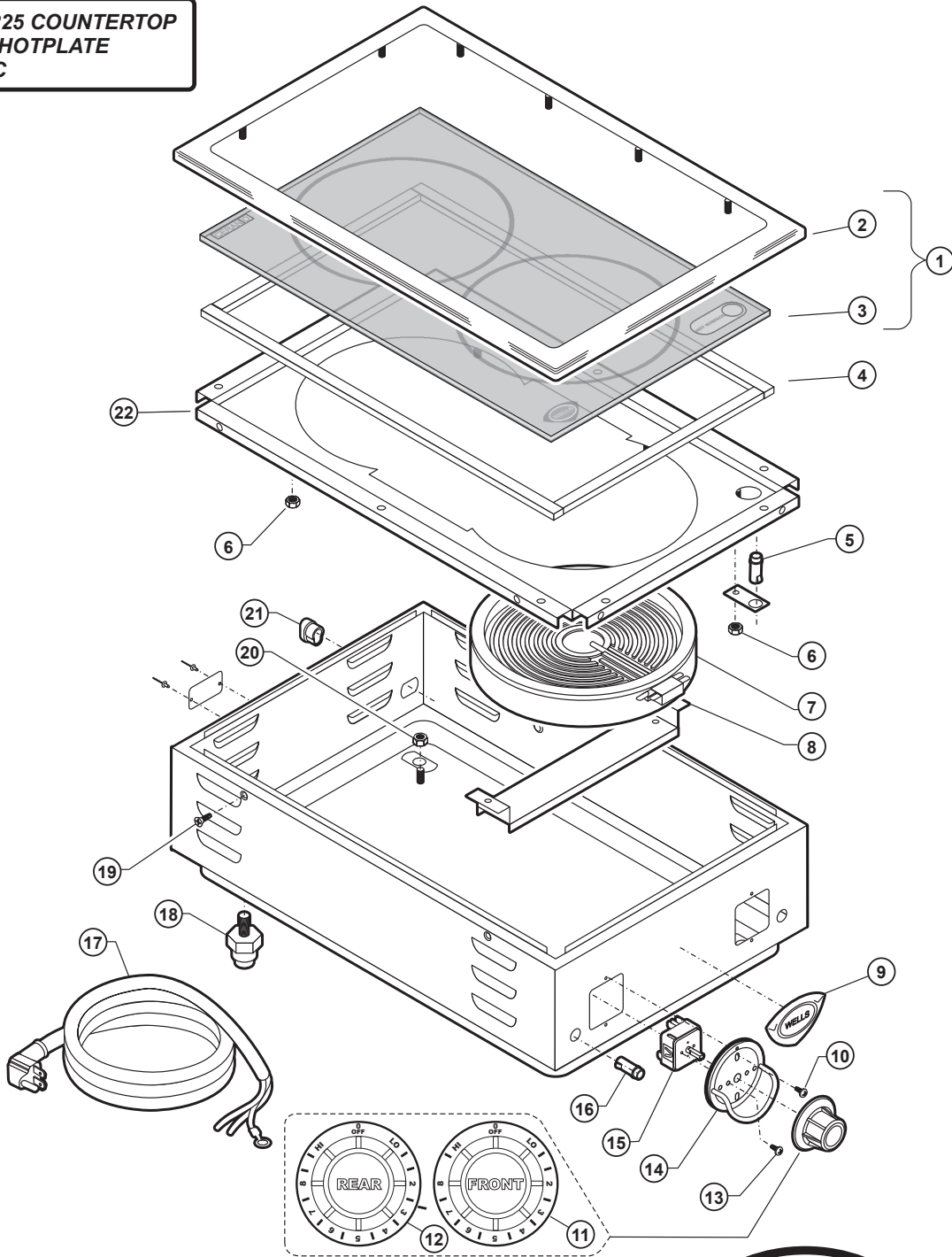

Model: HC225
Countertop Electric Ceramic Hotplate

PL223

IL1816 Rev. A 4/27/15

223 p/n 2M-303755 Owners Manual Counter Top Ceramic Hotplates

HC-225 COUNTERTOP ELECTRIC CERAMIC			
Fig No	Part No	Qty	Description
1	2Q-501650	1	TOP ASSY REPLACEMENT HC-225
2	I7-301215	1	TOP ASSY HC-225
3	WS-501110	1	GLASS CERAMIC HC-225 & 2256
4	2H-301213	6FT	INSUL LYTHERM HP 1/4X5/8
5	2J-301121	1	LIGHT SIGNAL CLEAR 120V
6	2C-31053	17	NUT 8-32 KEPS MS NICKEL
7	2N-301120	2	ELEM 240V 2500W
8	I7-301119	2	BRKT ELEMENT
9	2M-300534	1	TRADEMARK DOMED LABEL
10	2C-33935	4	SCREW 6ABX5/16 PH PAN SMS
11	2R-30583	1	KNOB ASSY FRONT HOTPLATE
12	2R-30584	1	KNOB RR HP91
13	2C-31697	4	SCREW 8-32X3/16 PH RD HD
14	D8-30256	2	TRIM RING ASSY
15	2E-30562	2	SWITCH INFINITE 240V A
16	2J-31157	2	LIGHT SIGNAL RED
17	2E-35259	1	CORD SET 250V 30A 12G 6-30P
18	2A-41946	4	LEG ADJUST 1IN
19	2C-34285	4	SCREW 8-32X3/8 PH
20	2C-35736	1	NUT 8-32 HEX KEPS MS GREEN
21	2K-45788	1	STRAIN RELIEF SR7W-2 LLF
22	I7-301145	1	RETAINER ELEMENT HC225

WIRING DIAGRAM

GLASS CERAMIC HOTPLATE HC-125 208/240V
AND HC-100 120V

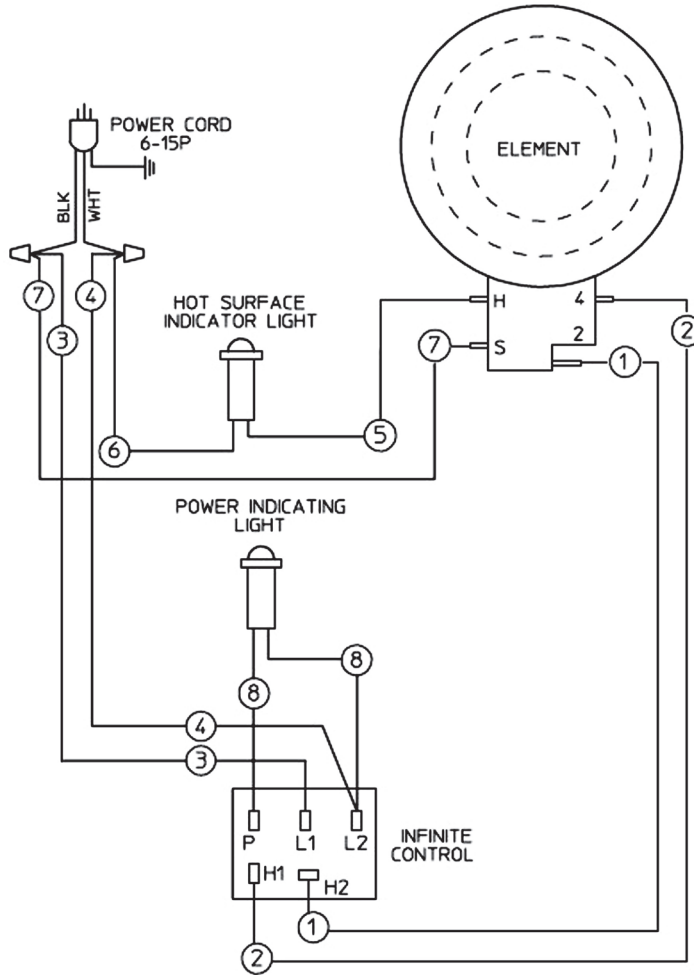

MODEL	VOLTS	KW	AMPS SINGLE PHASE
HC-100	120	1.4	11.7
HC-125	208	1.9	9.0
	240	2.5	10.4

PN 301146

WIRING DIAGRAM

WIRING DIAGRAM
GLASS CERAMIC HOTPLATE HC-225 208/240V

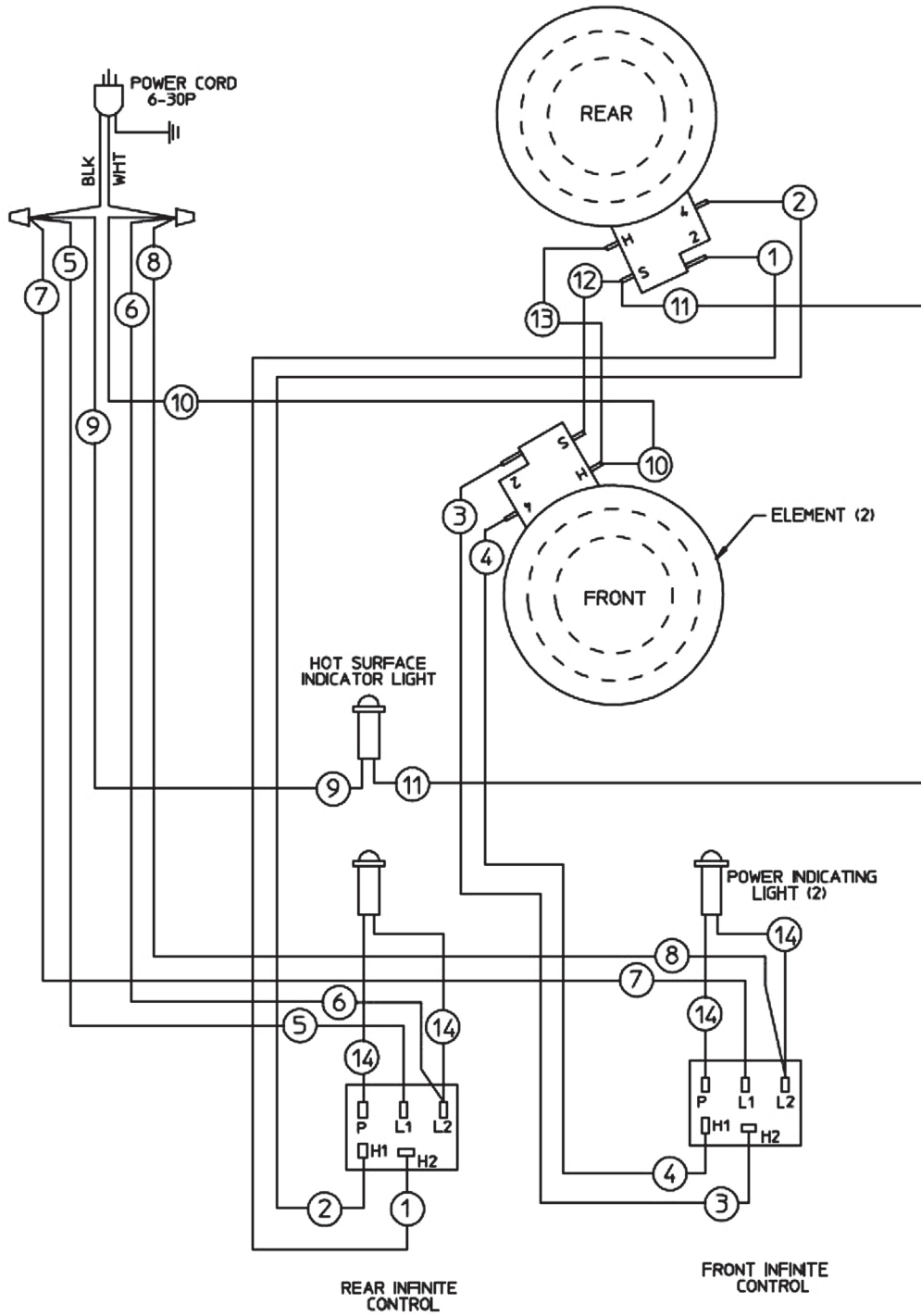

VOLTS	KW	AMPS SINGLE PHASE
208	3.8	18.1
240	5.0	20.8

301147 (A)

NOTES

NOTES

PARTS & SERVICE

DESCRIPTION SERVICE

PART NO.

SCRAPER, CLEANING

2R-302040

CLEANING CREME, CERAMIC HOTPLATE

2L-301124

IMPORTANT: Use only factory authorized service parts and replacement filters.

For factory authorized service, or to order factory authorized replacement parts, contact your Wells authorized service agency, or call:

Wells Manufacturing

10 Sunnen Dr.,
St. Louis MO 63143 USA

Service Dept.

phone: (314) 678-6314
fax: (314) 781-2714

Service Parts Department can supply you with the name and telephone number of the WELLS AUTHORIZED SERVICE AGENCY nearest you.

CUSTOMER SERVICE DATA

please have this information available if calling for service

RESTAURANT _____ LOCATION _____

INSTALLATION DATE _____ TECHNICIAN _____

SERVICE COMPANY _____

ADDRESS _____ STATE _____ ZIP _____

TELEPHONE NUMBER (____) ____ - _____

EQUIPMENT MODEL NO. _____ EQUIPMENT SERIAL NO. _____

VOLTAGE: (check one) 120 208 240



Wells Bloomfield proudly supports CFESA
Commercial Food Equipment Service Association

SERVICE TRAINING - QUALITY SERVICE



CUSTOMER SATISFACTION



WELLS MANUFACTURING

10 Sunnen Dr., St. Louis, MO 63143

telephone: 314-678-6314

fax: 314-781-2714

www.wellsbloomfield.com