

# B-40 CHAR BROILER

B-40 CHAR BROILER



**B-40**

Wells B-40 Countertop Broiler has a stainless steel top and sides that make this broiler one of the most durable in the industry. Self-cleaning elements are protected by the heavy-duty cast-iron grate and provide two heat zones for flexibility in broiling.

## Specifications

<b>Overall Dimensions:</b>	<b>Inches</b>	<b>MM</b>
Width	24 3/4	629
Depth	23 1/2	597
Height (incl. 4" legs)	15 3/8	391
<b>Grid Surface Dimensions:</b>		
Width	21 1/2	546
Depth	14 1/2	368
Area	312 in <sup>2</sup>	0.20 m <sup>2</sup>
<b>Temperature Settings:</b>	OFF/LO to HI	
<b>Number of Controls:</b>	2	
<b>Pre-Heat Time to 600° F:</b>	10 minutes	
<b>Typical Production</b>	<b>Per Load</b>	<b>Per Hour</b>
Hamburgers	24	336
Steaks	9	81
<b>Weights:</b>	<b>Lbs.</b>	<b>KG</b>
Installed	76	34
Shipping	80	36

## Accessories / Options

Cordset, 240V, 30 AMP, 1Ø, NEMA 6-30P, 20141

## Features

- Each self-cleaning element is positioned between the broiler grate ribs to protect against direct food contact and spatula abrasion. The elements also provide dual heating action (conductive and radiant).
- Temperature is regulated by infinite controls that have a positive-off position and signal lights to indicate a power-on condition.
- Element frame has a spring-loaded support rod to secure element when in a raised position.
- Lift-out, drawn drip pans with handles and removable cast iron grates allow fast and easy cleaning.
- Individual controls regulate one half of the grid surface area for cooking versatility and are mounted with a protective guard ring to help prevent accidental temperature changes.
- A terminal block is provided for field connection to the main power supply.
- Each unit is provided with a grate scraper/brush and 4" adjustable metal legs.
- The B-40 Broiler is Underwriters Laboratories, Inc. LISTED and meets NSF International standards.
- A one-year warranty against defects covers parts and labor.





## MODEL B-40 CHAR BROILER

### DIMENSIONS:

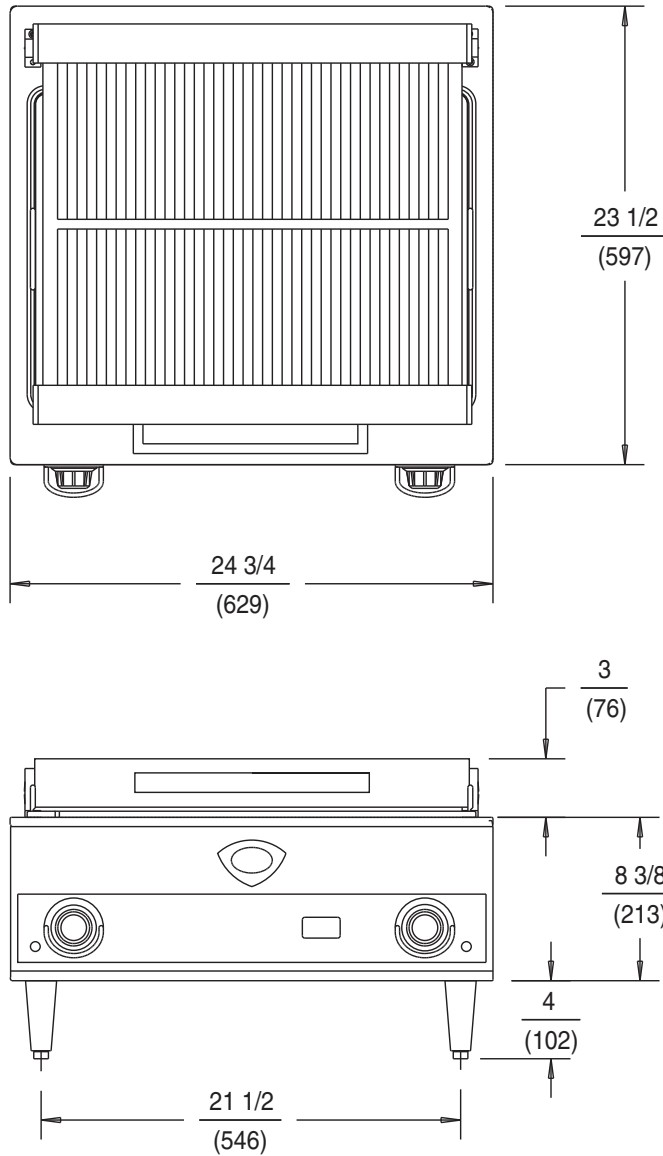

MINIMUM CLEARANCE REQUIRED FROM UNIT TO THE NEAREST COMBUSTIBLE OBJECT.			
BACK	SIDE	BOTTOM	TOP
6 (152)	7 (178)	4 (102)	21 (533)

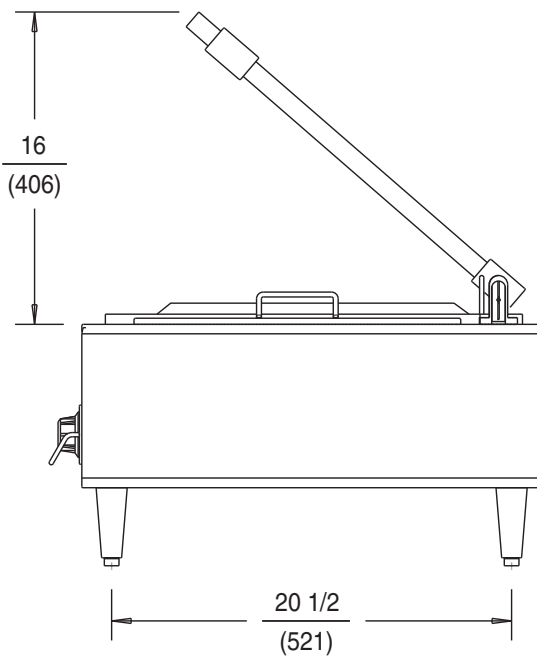

### B-40 ELECTRICAL SPECIFICATIONS:

MODELS	VOLTS	WATTS	AMPS PER LINE PHASE 3				AMPS SINGLE PHASE	POWER SUPPLY CORD
			L1	L2	L3	N		
B-40	208	5400	12.9	12.9	22.4	-	26.0	NONE
B-40	240	5400	11.2	11.2	11.2	-	22.5	NONE

NOTE: Specifications are subject to change without notice.

