

EMM20-1STD
Mixer



MODEL

EMM20-1STD 20-quart mixer

STANDARD FEATURES

- + Gear transmission
- + Three fixed speeds
- + Beater, whip and dough hook
- + Standard heavy-duty motor
- + 1 H.P. planetary output
- + Digital timer
- + Large, easy-to-use controls
- + Stainless steel bowl guard
- + Metallic gray styling
- + #12 taper attachment hub

ACCESSORY PACKAGE

- EMM20-1STD Standard accessory package (includes):
 - 20-quart stainless steel bowl
 - 20-quart beater
 - 20-quart whip
 - 20-quart dough hook

EMM20-1STD MIXER

SPECIFIER STATEMENT

Specified unit will provide a minimum 1 HP high torque motor. The gear driven transmission will have hardened alloy steel, anti-friction ball bearings. 3-speed controls for maximum performance with agitator RPM speeds of 35, 82, 151. Digital controls with sealed push buttons and Last Time Remind. Stainless steel bowl, wire whip, flat beater and dough hook provided as well as removable bowl guard.

Approved by _____ Date _____ Approved by _____ Date _____

SOLUTIONS/BENEFITS

STANDARD HEAVY-DUTY PERFORMANCE 

1 HP High Torque Heavy Duty Motor

Gear Transmission

- + Reduced downtime

Three Fixed Speeds

- + For incorporating, blending, mixing ingredients
- + Provides the right speeds for consistent performance

EASE OF USE 

Digital Timer with Last Time Remind

- + Sets minutes for accurate mixing performance
- + Eliminates overmixing
- + Remembers the last time set

Ergonomic Bowl lift with EZ Grip Handle

- + Designed with you in mind

Bayonet Style Agitators

- + Beater, whip and dough hook included

SANITATION & CLEANING 

Stainless Steel Bowl Guard

- + Ease of cleaning

OPERATOR ASSURANCE 

Triple Interlock System

- + Bowl-in-place
- + Bowl-up position
- + Bowl guard

EMM20 MIXER CAPACITY CHART

Recommended Maximum Capacities – dough capacities based on 70°F. water and 12% flour moisture. This device is suitable for applications that require up to 2 hours of mixing per day.

Product	Agitators Suitable for Operation	EMM20
CAPACITY OF BOWL (QUARTS LIQUID)		10
Egg Whites	whip	1 pt.
Mashed Potatoes	beater	15 lbs.
Meringue (quarts of water)	whip	1.5 pts.
Waffle or Hot Cake Batter	beater	8 qts.
Whipped Cream	whip	4 qts.
Cake, Box or Slab	beater	20 lbs.
Cake, Cup	beater	20 lbs.
Cake, Layer	beater	20 lbs.□
Cake, Pound	beater	20 lbs.□
Cookies, Sugar	beater	15 lbs.
Dough, Bread or Roll (Light-Medium) 60% AR	§	dough 25 lbs.□
Dough Pie	beater	18 lbs.□
Dough, Medium Pizza 50% AR	§‡	dough 10 lbs.□
Eggs & Sugar for Sponge Cake	beater	8 lbs.
Shortening & Sugar, Creamed	beater	16 lbs.
Pasta, Basic Egg Noodle (maximum mix time 5 minutes)	dough	5 lbs.

NOTE: % AR (% Absorption Ratio) – Water weight divided by flour weight. Capacity depends on moisture content of dough.

□ 1st Speed

* 2nd Speed

† 3rd Speed

§ If high gluten flour is used, reduce above dough batch size by 10%.

‡ 2nd Speed should never be used on 50% AR or lower products.

USE OF ICE REQUIRES A 10% REDUCTION IN BATCH SIZE.

1 gallon of water weighs 8.33 lb

NOTE: Attachment hub should not be used while mixing.

SPECIFICATIONS

Motor: 1 HP high torque heavy duty motor
120/60/1 8.0 Amps

Electrical: 120/60/1 – ETL Listed.

Controls: Solid state overload protection. Internally sealed “Start-Stop” push buttons. No Volt Release. Standard digital timer.

Transmission: Gear-driven. Gears are constant mesh heat-treated hardened alloy steel along with anti-friction ball bearings. Grease lubricants furnished to all gears and shafts.

Speeds:

	Agitator (RPM)	Attachment (RPM)
First	35	47
Second	82	107
Third	151	197

Bowl Guard: Stainless steel wire front and solid rear portion. Front portion of guard rotates easily to add ingredients and install or remove agitator. Rear portion of guard can be quickly cleaned in position. Guard must be in closed position before mixer will operate.

Bowl Lift: Ergonomic style, hand crank operated, easy to operate.

Finish: Metallic gray.

Attachment Hub: Comes with front-mounted Hobart standard #12 taper attachment hub for use with Hobart #12 size attachments.

Attachments & Accessories (Available at extra cost):

- BOWL-EMM20 – Stainless steel bowl
- BEATER-EMM20 – Flat beater
- WHIP-EMM20 – Wire whip
- DOUGH-EMM20 – Dough hook
- VS9 Vegetable slicer

Machine Voltages	
Service Current Requirement if Plug Connected	120/60/1
	15 Amp.
Terminal Designation of Plug	2 Pole 3 Wire Grounding
NEMA Plug Configuration	5-15P
Plug Configuration	
Molded Plug on Cord	Yes
Plug - Straight/Angle	Straight
NEMA Receptacle or Connector Configuration	5-15R

SPECIFICATIONS

Electrical Specifications: 120/60/1, ETL listed

Weight: 195 lbs. net; 158 lbs. domestic shipping.

Warranty: Unit has full one-year warranty on parts, labor and mileage against manufacturer's defects. Service contracts are available.

DETAILS AND DIMENSIONS

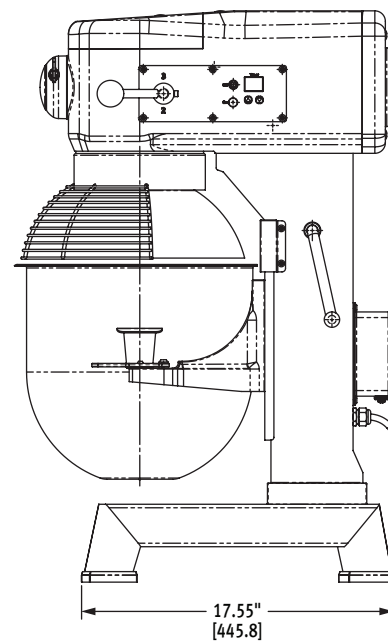
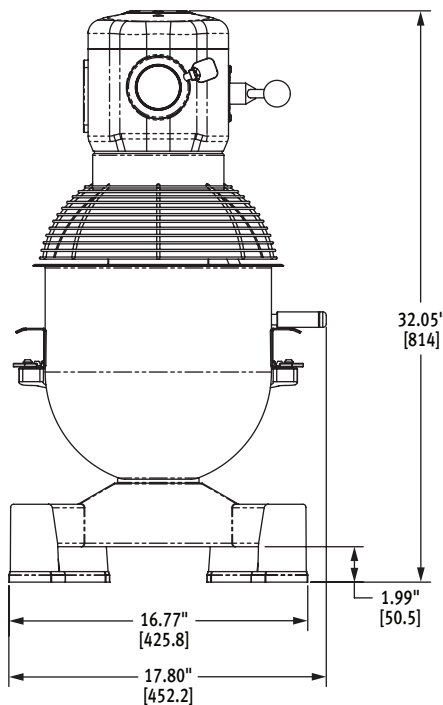
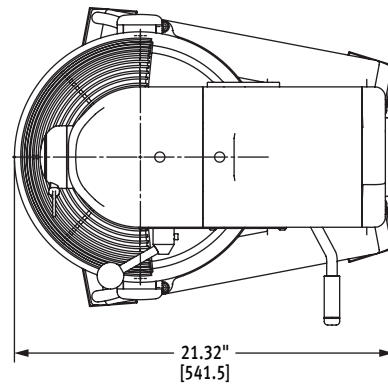
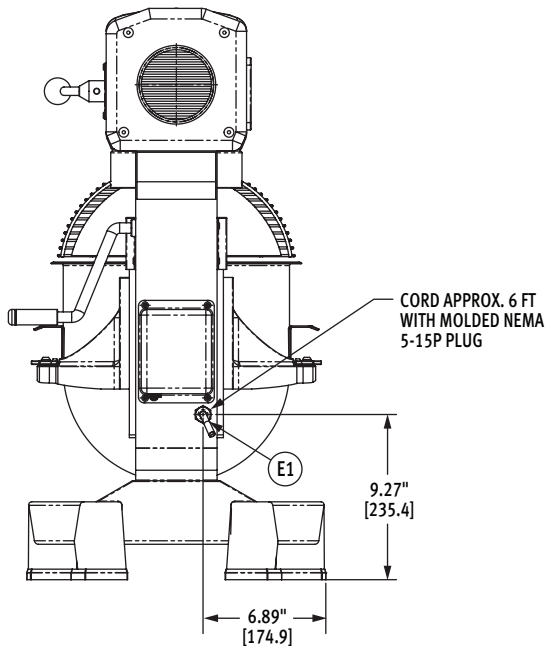

WARNING: Electrical and grounded connections must comply with the National Electrical Code and/or other local electrical codes in force.

E1 Electrical connection

MACHINE ELECTRICAL SPECS:
120/60/1 – ETL Listed

As continued product improvement is a policy of Hobart, specifications are subject to change without notice.