

iP0500

Manitowoc Ice Cube Machine

IDP0500A | IRP0500A | IYP0500A
IDP0500W | IYP0500W | IRP0500W

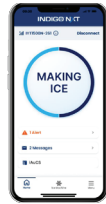

Get the App!



Indigo NXT Series iP0500
Ice machine on D570 bin.
Ice machine and bin sold separately.

ICE SHAPES



▶ **Half-Dice:** 3/8" x 1 1/8" x 7/8"
(0.95 x 2.86 x 2.22 cm)



▶ **Dice:** 7/8" x 7/8" x 7/8"
(2.22 x 2.22 x 2.22 cm)



▶ **Regular:** 1 1/8" x 1 1/8" x 7/8"
(2.86 x 2.86 x 2.22 cm)

SIZE

- ▶ Up to 516 lbs (234 kgs) of daily ice production
- ▶ 30" (76.20 cm) wide, 34" (86.36 cm) deep, and 71.5" (181.61 cm) high including 6" (15.25 cm) legs
- ▶ 532 lb (241 kgs) ice bin storage capacity*

*Application capacity based on 90% volume x 33 lbs./ft³ average density of ice

SPECIFICATIONS

Refrigerant: R290

- ▶ Air-cooled: 5.3 oz (150 g)
- ▶ Water-cooled: 5.3 oz (150 g)

BTU Per Hour

- ▶ 8,800 (average)
- ▶ 10,570 (peak)

Operating Limits

- ▶ Ambient temperature range: 35° to 110°F (1.7° to 43.3°C)
- ▶ Water temperature range: 40° to 90°F (4.4° to 32.2°C)
- ▶ Water pressure ice maker (water in)
 - Min. 20 psi (137.9 kPA)
 - Max. 80 psi (551.1 kPA)
- ▶ Water pressure condenser (water in)
 - Min. 20 psi (137.9 kPA)
 - Max. 275 psi (1,896 kPA)

Power: 115/60/1 and 230/60/1

- ▶ Air-cooled-115V
 - Minimum circuit ampacity: 11.7 amps
 - Maximum fuse size: 20 Amps
- ▶ Air-cooled-230V
 - Minimum circuit ampacity: 6.6 amps
 - Maximum fuse size: 15 Amps
- ▶ Water-cooled-115V
 - Minimum circuit ampacity: 11.0 amps
 - Maximum fuse size: 15 amps

FEATURES

- ▶ Sanitation
 - Hinged front door and removable components (water trough, tube, curtain, probe, pump) allow easy interior access and cleaning.
 - Select parts feature AlphaSan[®] antimicrobial protection.
 - DuraTech[™] exterior provides superior corrosion resistance compared to stainless steel. Innovative clear coat resists finger prints and dirt.
 - Optional LuminIce[®] Growth Inhibitor helps control bacteria and yeast, with status indicator on display.
 - ▶ Sustainability & Value
 - R290 offers low global warming potential and zero ozone depletion.
 - Energy-efficient models (see EnergyStar.gov)
 - Icon-based easyTouch[®] display simplifies operation.
 - Acoustical probe and Active Sense help ensure consistent ice production.
 - 24-hour diagnostics support preventative maintenance.
 - Designed with programmable ice production to take advantage of off-peak rates and/or shut off over night to lower lifetime costs.*
 - Connect via Bluetooth for quick setup and instant machine information.
- *Based on manufacturer assumptions without independent testing. Results may vary by settings and conditions.

ACCESSORIES

- ▶ LuminIce[®] II virus and bacteria inhibitor helps control viruses and bacteria in the ice machine.
- ▶ iAuCS[®] schedules and performs routine ice machine descaling or sanitizing automatically.
- ▶ Arctic Pure[®] Pro water filters reduce sediments and chlorine contaminants down to 0.5 microns. For optimal performance, use the Arctic Pure prefilter in combination with the Arctic Pure primary filter.



LuminIce II



iAuCS



Arctic Pure Water Filters

iP0500

Manitowoc Ice Cube Machine

IDP0500A | IYP0500A | IRP0500A | IDP0500W | IYP0500W | IRP0500W

INSTALLATION

Ice machine must be installed indoors.

Required clearance for
 - top and sides: 16" (40.64 cm)
 - back: 5" (12.7 cm)

- A** Electrical Entrance (2) Options
- B** 3/8" (0.95 cm) F.P.T. Water Condenser Inlet (water-cooled units)
- C** 1/2" (1.27 cm) F.P.T. Water Condenser Outlet (water-cooled units)
- D** 1/2" (1.27 cm) Auxiliary Base Drain Socket
- E** 3/8" (0.95 cm) F.P.T. Ice Making Water Inlet
- F** 1/2" (1.27 cm) F.P.T. Ice Making Water Drain
- G** 3/4" (1.91 cm) Bin Drain

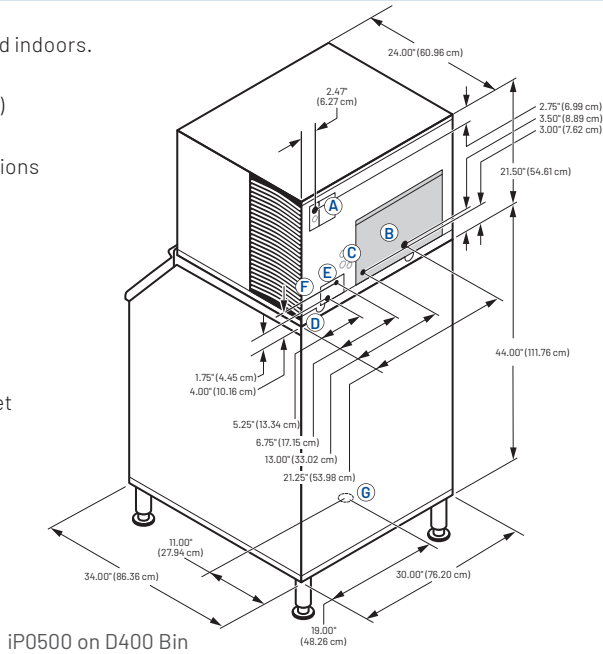

iP0500 on D400 Bin

SPACE-SAVING DESIGN



	iP0500 D400	iP0500 D570
Height	59.50" 151.13 cm	71.5" 181.61 cm
Width	30.0" 76.2 cm	30.0" 76.2 cm
Depth	34.0" 86.36 cm	34.0" 86.36 cm
Bin Storage	365 lbs 165 kgs	532 lbs 241 kgs

Height includes adjustable bin legs 6.00" to 8.00", (15.24 to 20.32 cm) set at 6.00" (15.24 cm).

Bin capacity is based on 90% of the volume x 33 lbs/ft³ average density of ice. Ice machine and bin sold separately.

SPECIFICATIONS

	Model	Ice Shape	Shipping Weight	Ice Production 24 Hours		Power Usage kWh per 100 lbs of ice	Ice Machine Potable water usage per 100 lbs ice	Condenser water usage per 100 lbs ice
				70° Air/50°F Water 21° Air/10°C Water	90° Air/70°F Water 32° Air/21°C Water			
Air Cooled	IDP0500A	Dice	149 lbs (67.59 kgs)	515 lbs (233.6 kgs)	421 lbs (190.9 kgs)	5.49 ★	14.6 gal (55.27 L)	N/A
	IYP0500A	Half-Dice	154 lbs (69.85 kgs)	516 lbs (234 kgs)	444 lbs (201.4 kgs)	5.12 ★	14.3 gal (54.13 L)	N/A
	IRP0500A	Regular	154 lbs (69.85 kgs)	509 lbs (230.8 kgs)	411 lbs (186.4 kgs)	5.52 ★	14.4 gal (54.51)	N/A
Water Cooled	IDP0500W	Dice	154 lbs (69.85 kgs)	496 lbs (224.9 kgs)	397 lbs (180 kgs)	4.85	13.9 gal (52.62 L)	135 gal (511 L)
	IYP0500W	Half-Dice	148 lbs (67.13 kgs)	509 lbs (230.8 kgs)	455 lbs (206.4 kgs)	4.32	14.2 gal (53.75)	135 gal (511 L)
	IRP0500W	Regular	154 lbs (69.85 kgs)	484 lbs (219.5 kgs)	374 lbs (169.6 kgs)	4.99	14.4 gal (54.51)	135 gal (511 L)

R290 is a refrigerant grade propane which is naturally occurring with no ozone depletion potential and extremely low global warming potential.

★ Energy Star Model

Limited Commercial Warranty

Ice Maker Three (3) years parts and labor

Evaporator Five (5) years parts and labor

Compressor Five (5) years parts, three (3) years labor



2110 South 26th Street | Manitowoc, WI 54220 | United States
 +1.920.682.0161 | 920.683.7589 Fax | manitowocice.com

All indicated Pentair trademarks and logos are property of Pentair. Third party registered and unregistered trademarks and logos are the property of their respective owners. ©2025 Pentair. All rights reserved.





Touchless Ice Dispensers

Model: SPA-312 SFA-292



SPA Model

Indigo NXT IT0450 Ice Machine
SPA-312 Ice Dispenser
*Ice machine and bin sold separately

SFA Model

Indigo NXT IT0450 Ice Machine
SFA-292 Ice & Water Dispenser
*Ice machine and bin sold separately

While both models are designed for filling ice buckets and glasses, the SFA model also dispenses filtered water with its built-in water valve. The touchless lever ensures that the ice chute is activated by a bucket or glass, not a hand. Coupled with an Indigo NXT ice machine, you can program it to be off at night—so while hotel guests are sleeping, the ice machine can be too!

Sanitation

- **Easy Interior Cleaning** - hinged front door swings wide open, providing easy access to food zone. Removable water trough, distribution tube, curtain, water probe and water pump allow complete, efficient cleaning. Select components made with AlphaSan® antimicrobial.
- **Low-Maintenance, Durable Exterior** - DuraTech® provides superior, corrosion resistance above stainless steel. Innovative clear coat resists fingerprints and dirt, helping keep the machine cleaner longer
- **Added Protection** - Available LuminIce® Growth Inhibitor helps control the growth of bacteria and yeast within the food zone. Indicator on the display provides operational status



Sustainability & Value

- **Ease of Operation** - easyTouch® Display takes the guesswork out of owning and operating an ice machine with icon-based touch screen
- **Consistent Output** - Acoustical Ice Sensing Probe and Active Sense ensure consistent harvest, even in challenging water conditions and environments
- **Intelligent Diagnostics** - worry-free operation with 24-hour preventative maintenance and diagnostic feedback
- **Cost Savings** - reduce energy costs with programmable Ice production by scheduling during lower rate hours and controlling daily ice volume
- **Overall Lifetime Value** - lower cost of ownership over the life of machine with decreased energy consumption as compared to legacy R404A models

Standard Features

- **Robust** - 180 lbs. (82 kgs.) ice storage capacity. Accepts 22" (55.88 cm) or 30" (76.2 cm) wide Manitowoc ice machine.
- **Space-Saving** - Only 30" (76.2 cm) wide, 32" (81.28 cm) deep, and 82" high (208.28 cm).
- **Touchless** - The touchless lever eliminates the need to touch the machine using hands to dispense ice.
- **Reliable Operation** - Efficient built-in agitator assures 100% dispensing. Oversized drain pan collects larger quantity of ice overflow.
- **Long-lasting** - DuraTech™ exterior provides superior corrosion resistance. Stainless finish with innovative clear-coat resists fingerprints and dirt.

Ice Shape



Half Dice

$\frac{3}{8}" \times 1\frac{1}{8}" \times \frac{7}{8}"$
(0.95 x 2.86 x 2.22 cm)



Dice

$\frac{7}{8}" \times \frac{7}{8}" \times \frac{7}{8}"$
(2.22 x 2.22 x 2.22 cm)



Touchless Ice Dispensers

Installation Note

Dispensers have no minimum clearance, when installing an ice machine/dispenser combination follow the clearance requirements for the ice machine being installed.

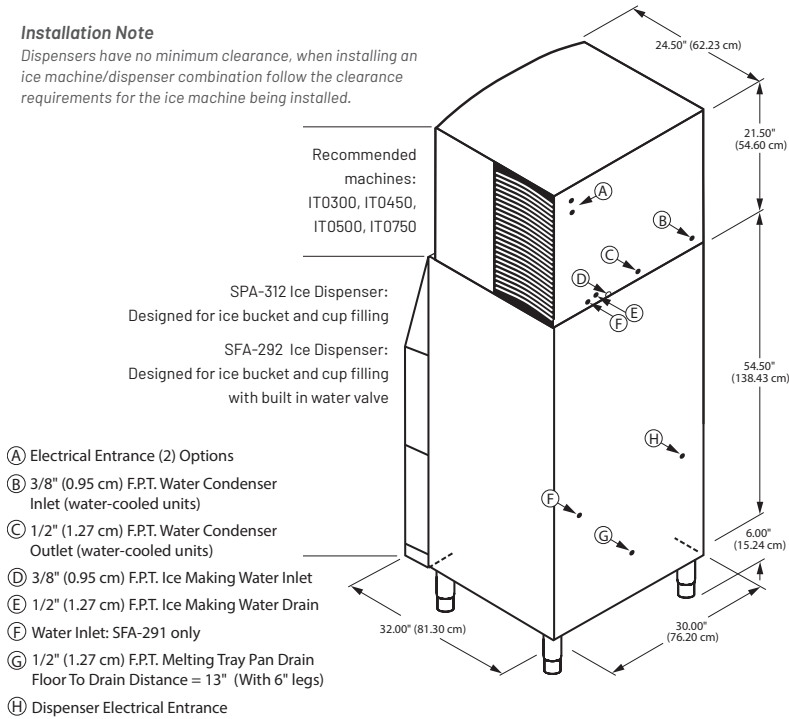

Ice Machine Electric

- Note** - Dispenser will accept single 22" or 30" wide ice machine.* Ice machine ordered separately. Choose Dice or Half Dice cube size. Refer to ice machine specification sheet for electrical and complete AHRI.
 - Dispenser Electric** - 115/60/1 and 230/50/1
 - Maximum Circuit Fuse Size** - 15.0 amps. HACR-type circuit breakers can be used in place of fuses.
 - Dispenser Electrical Connection** - 6' power cord, rated 125 VAC, 16-3 conductors with standard 3-prong, straight-blade, ground-type plug (NEMA configuration 5-15P).
 - Motor** - 1.6 amps maximum. Permanently lubricated.
 - Service Access** - Dispenser door removes easily to access components.
 - Model Options** - SPA-312 touch-less activated lever only; SPA-292 touch-less activated lever with water valve
- * 22" wide ice machines on 30" wide dispensers require K-00365 Adapter & K-00348 Baffle.

Specifications

	Model	Ice Shape	Ice Production 24 Hours	
			70° Air/ 50° F Water	90° Air/ 70° F Water
SERIES IT0300 (115 VOLT)	IDT0300A	dice	305 lbs/138 kgs	230 lbs/104 kgs
	IDT0300W		305 lbs/138 kgs	258 lbs/117 kgs
	IYT0300A	half-dice	310 lbs/141 kgs	230 lbs/104 kgs
	IYT0300W		310 lbs/141 kgs	260 lbs/118 kgs

	Model	Ice Shape	Ice Production 24 Hours	
			70° Air/ 50° F Water	90° Air/ 70° F Water
SERIES IT0500 (115 VOLT)	IDT0500A	dice	520 lbs/236 kgs	400 lbs/181 kgs
	IDT0500W		500 lbs/227 kgs	400 lbs/181 kgs
	IYT0500A	half-dice	550 lbs/249 kgs	440 lbs/200 kgs
	IYT0500W		535 lbs/243 kgs	460 lbs/209 kgs

	Model	Ice Shape	Ice Production 24 Hours	
			70° Air/ 50° F Water	90° Air/ 70° F Water
SERIES IT0450 (115 VOLT)	IDT0450A	dice	470 lbs/213 kgs	358 lbs/162 kgs
	IDT0450W		430 lbs/196 kgs	360 lbs/163 kgs
	IYT0450A	half-dice	490 lbs/222 kgs	378 lbs/171 kgs
	IYT0450W		470 lbs/213 kgs	420 lbs/191 kgs

	Model	Ice Shape	Ice Production 24 Hours	
			70° Air/ 50° F Water	90° Air/ 70° F Water
SERIES IT0750 (208-230 VOLT)	IDT0750A	dice	632 lbs/287 kgs	490 lbs/222 kgs
	IDT0750W		661 lbs/300 kgs	575 lbs/261 kgs
	IYT0750A	half-dice	635 lbs/288 kgs	555 lbs/252 kgs
	IYT0750W		700 lbs/318 kgs	580 lbs/263 kgs

Accessories

LuminIce® Virus and Bacteria Inhibitor

Controls viruses and bacteria in the ice machine.



Arctic Pure® Plus Water Filters

Reduces sediments and contaminants down to 0.5 microns, and 95% of chlorine taste & odor. Use with a pre-filter is recommended.



Commercial Warranty - Dispenser three (3) years parts and labor
 Ice Maker three (3) years parts and labor
 Evaporator five (5) years parts and labor
 Compressor five (5) years parts, three (3) years labor



2110 South 26th Street | Manitowoc, WI 54220 | United States
 920.682.0161 (US Only) | 920.683.7589 Fax | manitowocice.com

All indicated Pentair trademarks and logos are property of Pentair. Third party registered and unregistered trademarks and logos are the property of their respective owners.
 ©2023 Pentair. All rights reserved.