

Get the App!

Indigo NXT Series iP0450 ice machine on D570 bin.
Ice machine and bin sold separately.

ICE SHAPES



▶ **Half-Dice:** 3/8" x 1 1/8" x 7/8"
(0.95 x 2.86 x 2.22 cm)



▶ **Dice:** 7/8" x 7/8" x 7/8"
(2.22 x 2.22 x 2.22 cm)

SIZE

- ▶ Up to 478 lbs (216 kgs) of daily ice production
- ▶ 30" (76.20 cm) wide, 34" (86.36 cm) deep, and 71.5" (181.61 cm) high including 6" (15.25 cm) legs
- ▶ 532 lbs (241.1 kgs) ice storage capacity*

*Application capacity based on 90% volume x 33 lbs./ft³ average density of ice

SPECIFICATIONS

Refrigerant: R290

- ▶ Air-cooled: 5.9 oz (170 g)
- ▶ Water-cooled 5.3 oz (150 g)

BTU Per Hour

- ▶ 8,800 average
- ▶ 10,570 peak

Operating Limits

- ▶ Ambient temperature range: 40° to 110°F (4.4° to 43.3°C)
- ▶ Water temperature range: 40° to 90°F (4.4° to 32.2°C)
- ▶ Water pressure ice maker (water in)
 - Min. 20 psi (137.9 kPa)
 - Max. 80 psi (551.1 kPa)
- ▶ Condenser inlet water in (water-cooled only)
 - Min. 20 psi (137.9 kPa)
 - Max. 276 psi (1,902.95 kPa)

Power: 115/60/1 and 230/60/1

- ▶ Air-cooled-115V
 - Minimum circuit ampacity: 11.9 amps
 - Maximum fuse size: 20 Amps
- ▶ Water-cooled-115V
 - Minimum circuit ampacity: 11.2 amps
 - Maximum fuse size: 15 Amps

FEATURES

- ▶ Sanitation
 - Hinged front door and removable components (water trough, tube, curtain, probe, pump) allow easy interior access and cleaning.
 - Select parts feature AlphaSan[®] antimicrobial protection.
 - DuraTech[™] exterior provides superior corrosion resistance compared to stainless steel. Innovative clear coat resists finger prints and dirt.
 - Optional LuminIce[®] Growth Inhibitor helps control bacteria and yeast, with status indicator on display.
 - ▶ Sustainability & Value
 - R290 offers low global warming potential and zero ozone depletion.
 - Energy-efficient models (see EnergyStar.gov)
 - Icon-based easyTouch[®] display simplifies operation.
 - Acoustical probe and Active Sense help ensure consistent ice production.
 - 24-hour diagnostics support preventative maintenance.
 - Designed with programmable ice production to take advantage of off-peak rates and/or shut off over night to lower lifetime costs.*
 - Connect via Bluetooth for quick setup and instant machine information.
- *Based on manufacturer assumptions without independent testing. Results may vary by settings and conditions.

ACCESSORIES

- ▶ LuminIce[®] II virus and bacteria inhibitor helps control viruses and bacteria in the ice machine.
- ▶ iAuCS[®] schedules and performs routine ice machine descaling or sanitizing automatically.
- ▶ Arctic Pure[®] Pro water filters reduce sediments and chlorine contaminants down to 0.5 microns.
For optimal performance, use the Arctic Pure prefilter in combination with the Arctic Pure primary filter.



LuminIce II



iAuCS



Arctic Pure Water Filters

iP0450

Manitowoc Ice Cube Machine

IDP0450A | IYP0450A | IDP0450W | IYP0450W

INSTALLATION

Ice machine must be installed indoors

Minimum clearances:

- top and sides: 8" (30.5 cm)
- back: 5" (12.7 cm)

- A** Electrical Entrance two (2) options
- B** 3/8" (0.95 cm) F.P.T. Water Condenser Inlet (water-cooled units)
- C** 1/2" (1.27 cm) F.P.T. Water Condenser Outlet (water-cooled units)
- D** 1/2" (1.27 cm) Auxiliary Base Drain Socket
- E** 3/8" (0.95 cm) F.P.T. Ice Making Inlet
- F** 1/2" (1.27 cm) F.P.T. Ice Making Drain
- G** 3/4" (1.91 cm) Bin Drain

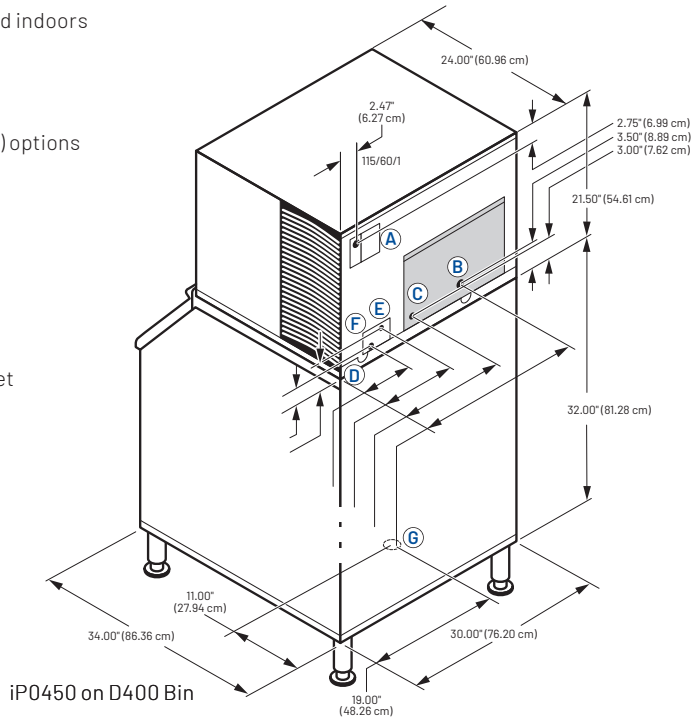

SPACE-SAVING DESIGN



	iP0450 D400	iP0450 D570
Height	59.50" 151.13 cm	71.5" 181.61 cm
Width	30.0" 76.2 cm	30.0" 76.2 cm
Depth	34.0" 86.36 cm	34.0" 86.36 cm
Bin Storage	365 lbs 165 kgs	532 lbs 241 kgs

Height includes adjustable bin legs 6.00" to 8.00", (15.24 to 20.32 cm) set at 6.00" (15.24 cm).

Bin capacity is based on 90% of the volume x 33 lbs/ft³ average density of ice. Ice machine and bin sold separately.

SPECIFICATIONS

	Model	Ice Shape	Shipping Weight	Ice Production 24 Hours		Power Usage kWh per 100 lbs of ice	Ice Machine Potable water usage per 100 lbs ice	Condenser water usage per 100 lbs ice
				70° Air/50°F Water 21° Air/10°C Water	90° Air/70°F Water 32° Air/21°C Water			
Air Cooled	IDP0450A	Dice	152 lbs (68.94 kgs)	463 lbs (210 kgs)	393 lbs (178 kgs)	5.54 ★	14.6 gal (55.27 L)	—
	IYP0450A	Half-Dice	150 lbs (68.04 kgs)	478 lbs (216 kgs)	413 lbs (187 kgs)	5.84	14.7 gal (55.65 L)	—
Water Cooled	IDP0450W	Dice	150 lbs (68.04 kgs)	456 lbs (206 kgs)	395 lbs (179 kgs)	4.89	14.6 gal (55.27 L)	140 gal (530 L)
	IYP0450W	Half-Dice	150 lbs (68.04 kgs)	464 lbs (210 kgs)	399 lbs (181 kgs)	4.82	14.5 gal (54.89 L)	140 gal (530 L)

R290 is a refrigerant grade propane which is naturally occurring with no ozone depletion potential and extremely low global warming potential.

★ Energy Star Model

Limited Commercial Warranty

Ice Maker Three (3) years parts and labor

Evaporator Five (5) years parts and labor

Compressor Five (5) years parts, three (3) years labor



2110 South 26th Street | Manitowoc, WI 54220 | United States
+1.920.682.0161 | 920.683.7589 Fax | manitowocice.com

All indicated Pentair trademarks and logos are property of Pentair. Third party registered and unregistered trademarks and logos are the property of their respective owners. ©2025 Pentair. All rights reserved.

6478 Rev D DE25