

Adaptive Scupper System

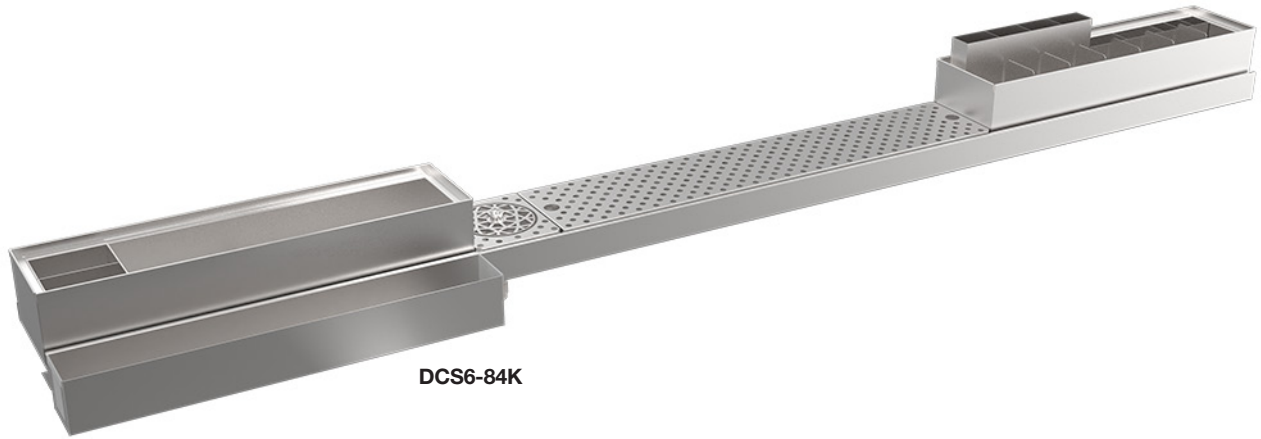

DCS6-84K

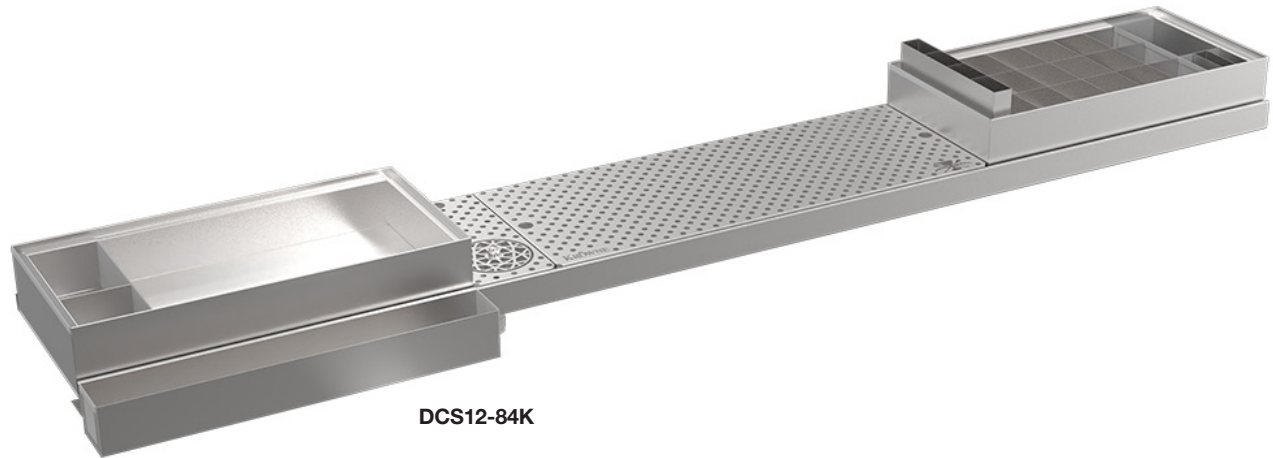

DCS12-84K

Model	Description	Weight	Includes
DCS6-84K	Death & Co Adaptive Scupper System, 6" Kit, Includes Jet Rinser/Drainboard, Cheaterbox, & Garnish Box	44 lbs.	DSC6-36J, DSC6-24C, DSC6-24G
DCS12-84K	Death & Co Adaptive Scupper System, 12" Kit, Includes Jet Rinser/Drainboard, Cheaterbox, & Garnish Box	60 lbs.	DSC12-36J, DSC12-24C, DSC12-24G

Standard Features

- Organized station = better flow: keeps tools and workspace organized and dry, supporting faster, more consistent service
- Adaptable for any bartender: sections can be rearranged to match personal preferences or left/right-handed setups
- Consistent brand aesthetic: uniform design across multiple bars or locations creates a cohesive, professional appearance
- Smooth workflow: properly placed scupper rails reduce clutter and help bartenders move efficiently
- Elevated work area: gives bartender space to finish or create cocktail for overall visual presentation
- Tool storage: multi-facet tool storage capabilities plus bitter storage as well
- Fully insulated: garnish box fully insulated to keep garnishes fresh for long periods of time



Adaptive Scupper Cheaterbox

Death & Co

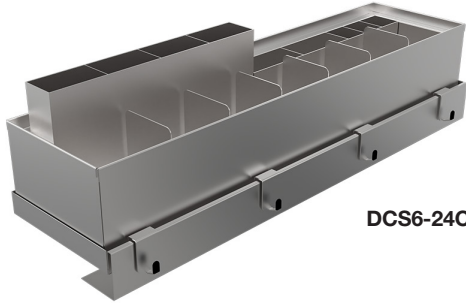

DCS6-24C

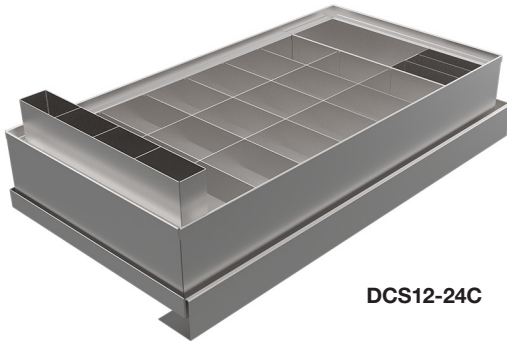

DCS12-24C

Model	Description
DCS6-24C	Death & Co Adaptive Scupper Cheaterbox, 6" x 24"
DCS12-24C	Death & Co Adaptive Scupper Cheaterbox, 12" x 24"

Standard Features

- Organized station = better flow: keeps tools and workspace organized and dry, supporting faster, more consistent service
- Adaptable for any bartender: sections can be rearranged to match personal preferences or left/right-handed setups
- Consistent brand aesthetic: uniform design across multiple bars or locations creates a cohesive, professional appearance
- Smooth workflow: properly placed scupper rails reduce clutter and help bartenders move efficiently
- Elevated work area: gives bartender space to finish or create cocktail for overall visual presentation
- Tool storage: multi-facet tool storage capabilities plus bitter storage as well
- Fully insulated: garnish box fully insulated to keep garnishes fresh for long periods of time

Specifications

Height	1"
Width	24.1"
Material	Stainless steel
Weight	17.5 lbs. (DCS6-24C) 27.5 lbs. (DCS12-24C)

DCS6-24C

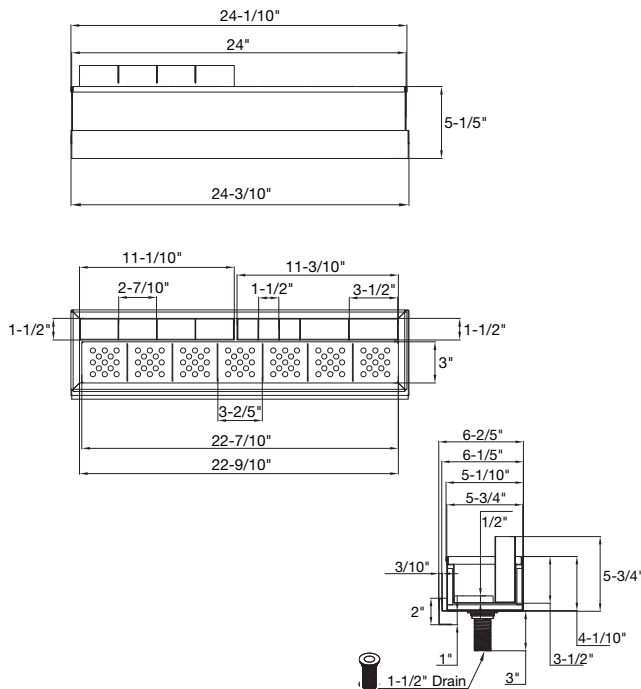

DCS12-24C

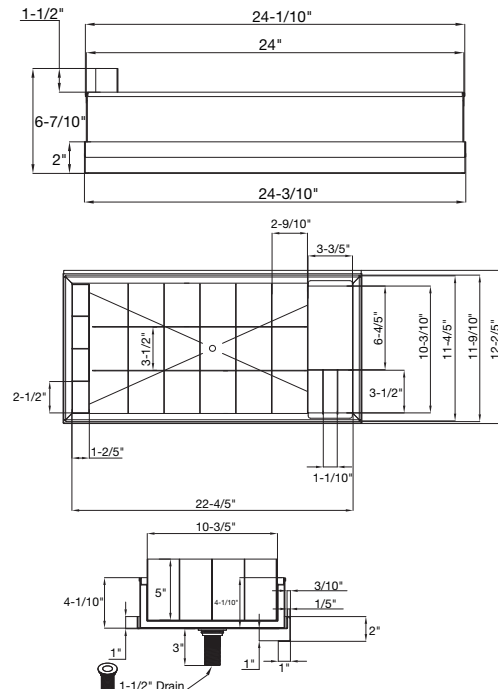

Adaptive Scupper Garnish Box



DCS6-24G

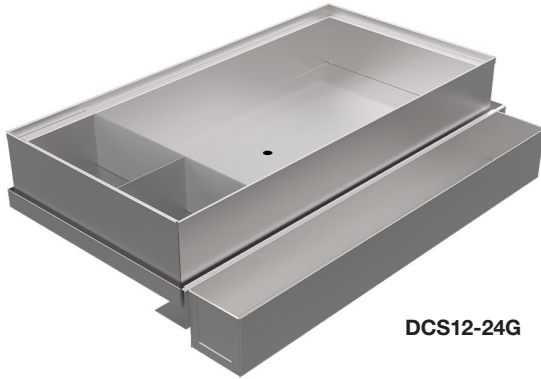

DCS12-24G

Model	Description
DCS6-24G	Death & Co Adaptive Scupper Garnish box, 6" x 24"
DCS12-24G	Death & Co Adaptive Scupper Garnish box, 12" x 24"

Standard Features

- Organized station = better flow: keeps tools and workspace organized and dry, supporting faster, more consistent service
- Adaptable for any bartender: sections can be rearranged to match personal preferences or left/right-handed setups
- Consistent brand aesthetic: uniform design across multiple bars or locations creates a cohesive, professional appearance
- Smooth workflow: properly placed scupper rails reduce clutter and help bartenders move efficiently
- Elevated work area: gives bartender space to finish or create cocktail for overall visual presentation
- Tool storage: multi-facet tool storage capabilities plus bitter storage as well
- Fully insulated: garnish box fully insulated to keep garnishes fresh for long periods of time

Specifications

Height	1"
Width	24.1"
Material	Stainless steel
Weight	18.2 lbs. (DCS6-24G) 20.1 lbs. (DCS12-24G)

DCS6-24G

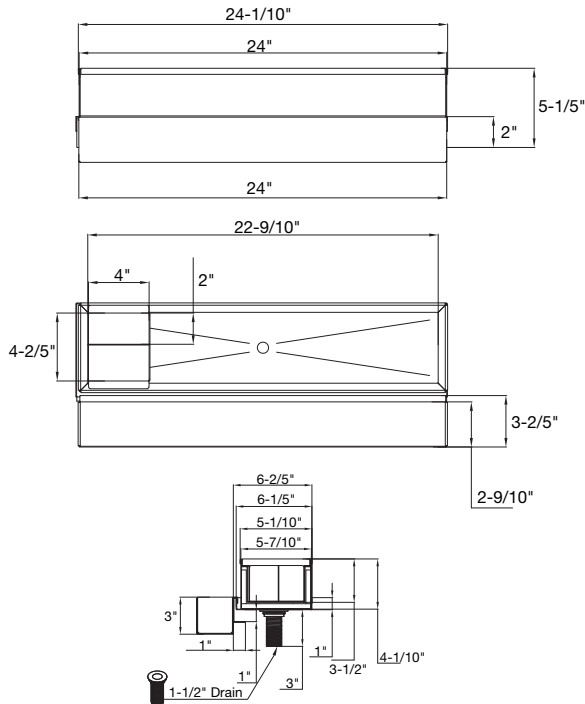

DCS12-24G

