



**IMPORTANT FOR FUTURE REFERENCE**

Please complete this information and retain this manual for the life of the equipment:

Model #: \_\_\_\_\_

Serial #: \_\_\_\_\_

Date Purchased: \_\_\_\_\_

# OPERATOR'S MANUAL

## Marathoner Gold HALF-SIZE ELECTRIC CONVECTION OVENS

Models

- |          |          |
|----------|----------|
| EH-10CCH | EH-20CCH |
| EH-10PC  | EH-20PC  |
| EH-10RT  | EH-20RT  |
| EH-10SC  | EH-20SC  |



Model EH-10SC



Model EH-20SC

**! WARNING**

Improper installation, adjustment, alteration, service or maintenance can cause property damage, injury or death. Read the installation, operating and maintenance instructions thoroughly before installing or servicing this equipment.

1100 Old Honeycutt Road, Fuquay-Varina, NC 27526  
www.southbendnc.com

MANUAL 1184093 REV 1  
\$18.00



HALF-SIZE ELECTRIC CONVECTION OVENS  
MANUAL SECTION CO

# SAFETY PRECAUTIONS

Before installing and operating this equipment, be sure everyone involved in its operation is fully trained and aware of precautions. Accidents and problems can be caused by failure to follow fundamental rules and precautions.

The following symbols, found throughout this manual, alert you to potentially dangerous conditions to the operator, service personnel, or to the equipment.



This symbol warns of immediate hazards which will result in severe injury or death.



This symbol refers to a potential hazard or unsafe practice which could result in injury or death.



This symbol refers to a potential hazard or unsafe practice which could result in injury, product damage, or property damage.



This symbol refers to information that needs special attention or must be fully understood, even though not dangerous.

**! WARNING  
FIRE HAZARD  
FOR YOUR SAFETY**

Do not store or use gasoline or other flammable vapors and liquids in the vicinity of this or any other appliance.  
Keep area around appliances free and clear of combustibles.

**! WARNING  
SHOCK HAZARD  
FOR YOUR SAFETY**

Do not open panels that require the use of tools.  
Unit must be cleaned daily and properly maintained to reduce chances of unsafe operating conditions.

**NOTICE**

Be sure this Operator's Manual and important papers are given to the proper authority to retain for future reference.

**NOTICE**

This product is intended for commercial use only. NOT FOR HOUSEHOLD USE.

Congratulations! You have purchased one of the finest pieces of heavy-duty commercial cooking equipment on the market.

You will find that your new equipment, like all Southbend equipment, has been designed and manufactured to meet the toughest standards in the industry. Each piece of Southbend equipment is carefully engineered and designs are verified through laboratory tests and field installations. With proper care and field maintenance, you will experience years of reliable, trouble-free operation. **For best results, read this manual carefully.**

RETAIN THIS MANUAL FOR FUTURE REFERENCE.

## Table of Contents

Specifications .....	4
Installation .....	8
Operation.....	17
Cooking Hints .....	28
Cleaning .....	31
Adjustments.....	33
Troubleshooting.....	36
Parts .....	51

Read these instructions carefully before attempting installation. Installation and initial startup should be performed by a qualified installer. Unless the installation instructions for this product are followed by a qualified service technician (a person experienced in and knowledgeable with the installation of commercial gas an/or electric cooking equipment) then the terms and conditions on the Manufacturer's Limited Warranty will be rendered void and no warranty of any kind shall apply.

In the event you have questions concerning the installation, use, care, or service of the product, write to:

Southbend  
1100 Old Honeycutt Road  
Fuquay-Varina, North Carolina 27526 USA

The serial plate is located on the interior side of the lower front panel, as shown below.

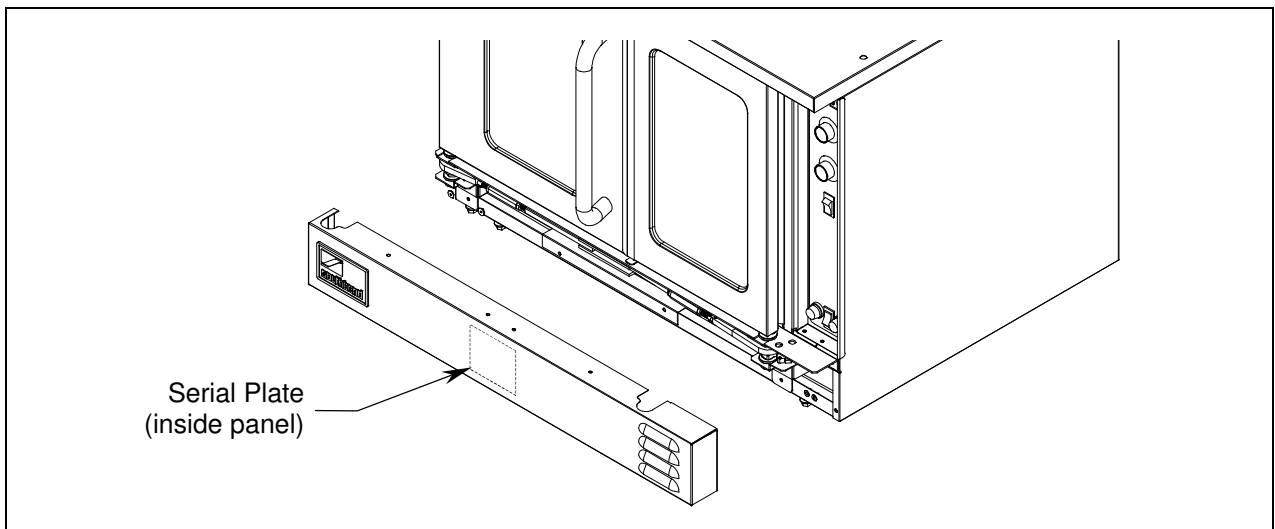



# SPECIFICATIONS

## NOTICE

The appliance, when installed, must be electrically grounded and comply with local codes, or in the absence of local codes, with the *National Electrical Code, ANSI/NFPA 70*, or the *Canadian Electrical Code, CSA C22.2*, as applicable.

Southbend reserves the right to change specifications and product design without notice. Such revisions do not entitle the buyer to corresponding changes, additions, or replacements for previously purchased equipment.

This product is intended for commercial use only, not for household use.

## ELECTRICITY SUPPLY

The following table lists the electricity supply requirements PER OVEN (double for dual-oven models).

Supply Voltage	Oven Component	Total kW	3-Phase Loading (kW/phase)			Nominal Amperes per Line-Wire				Minimum Supply Wire (AWG) Size	
			L1-L2	L2-L3	L1-L3	3-Phase			1-Phase Total	3-Phase	1-Phase
480	Heating Elements	7.50	2.50	2.50	2.50	11.0	11.0	11.0	18.0	12	10
	Motor & Controls	0.90	0.00	0.00	0.90	2.2	0.0	2.2	2.2		
415	Heating Elements	7.50	2.50	2.50	2.50	11.0	11.0	11.0	34.0	12	6
	Motor & Controls	0.90	0.00	L3-N	0.90	0.0	0.0	3.8	3.8		
380	Heating Elements	7.50	2.50	2.50	2.50	12.0	12.0	12.0	20.0	12	8
	Motor & Controls	0.90	0.00	L3-N	0.90	0.0	0.0	4.1	4.1		
240	Heating Elements	7.50	2.50	2.50	2.50	19.0	19.0	19.0	33.0	8	6
	Motor & Controls	0.90	0.00	0.00	0.90	3.8	0.0	3.8	3.8		
220 (50Hz)	Heating Elements	6.40	1.91	1.91	1.91	17.0	17.0	17.0	29.0	8	6
	Motor & Controls	0.90	0.00	0.00	0.90	4.1	0.0	4.1	4.1		
208	Heating Elements	7.50	2.50	2.50	2.50	21.0	21.0	21.0	36.0	8	4
	Motor & Controls	0.90	0.00	0.00	0.90	4.3	0.0	4.3	4.3		

An electrical diagram is located on the side of the control panel assembly (see drawing on page 37). Electrical diagrams can also be found in this manual beginning on page 38.

The electrical connections are made directly to the terminals of the heating-element contactor, which is located inside the control-panel compartment on the right side of the oven. A circular opening sized for a strain-relief fitting is located on the back of the oven near the right side (right as seen from the front of the oven, see illustration on page 15). Models with two stacked ovens have a separate electrical connection for each oven.

Use 167°F (75°C) wire for all supply lines.

Ovens are shipped wired for either single-phase or three-phase operation, depending on which was specified on the factory order. If necessary, an oven can be field-converted to use either single-phase or three-phase power (see page 34).



DIMENSIONS

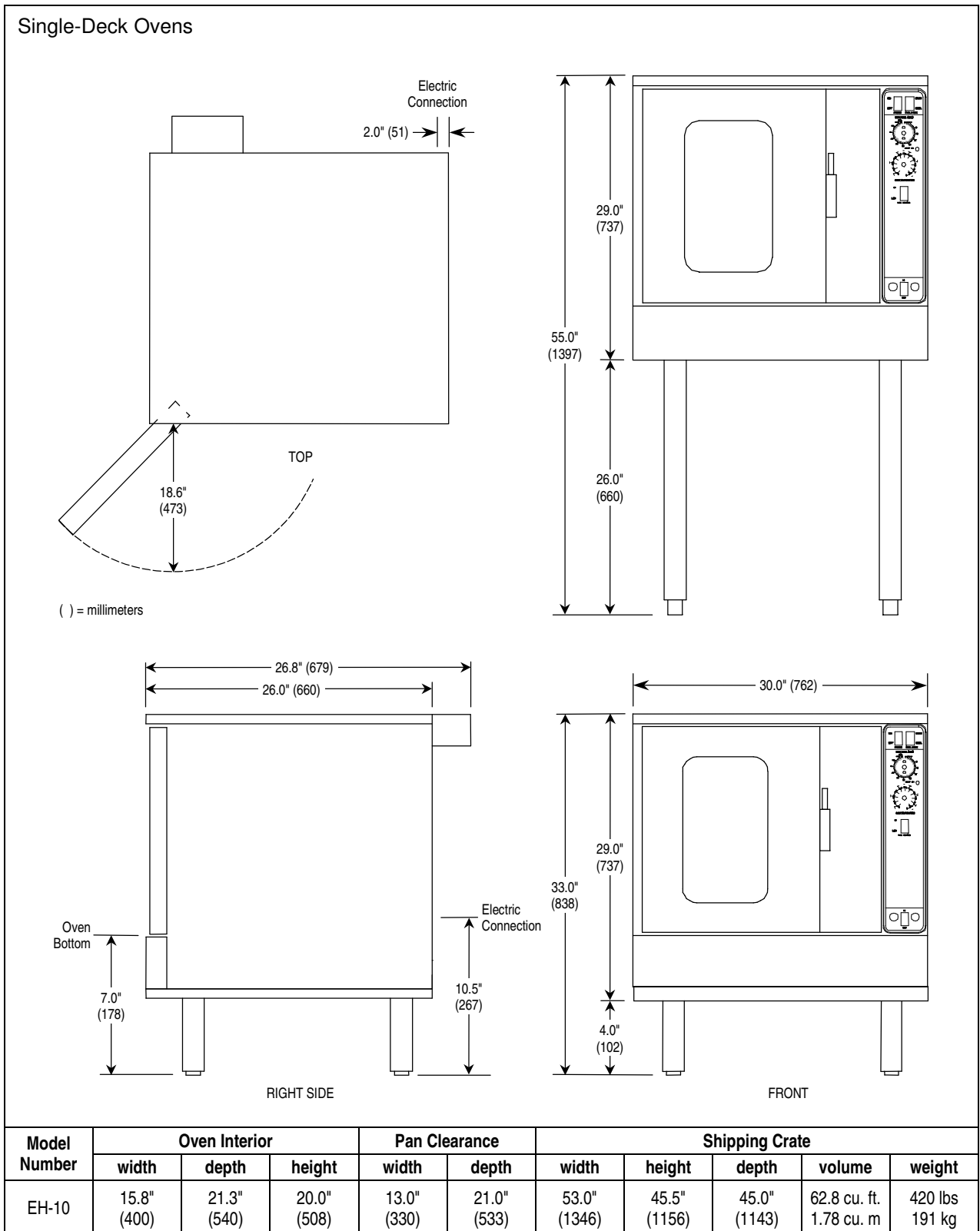

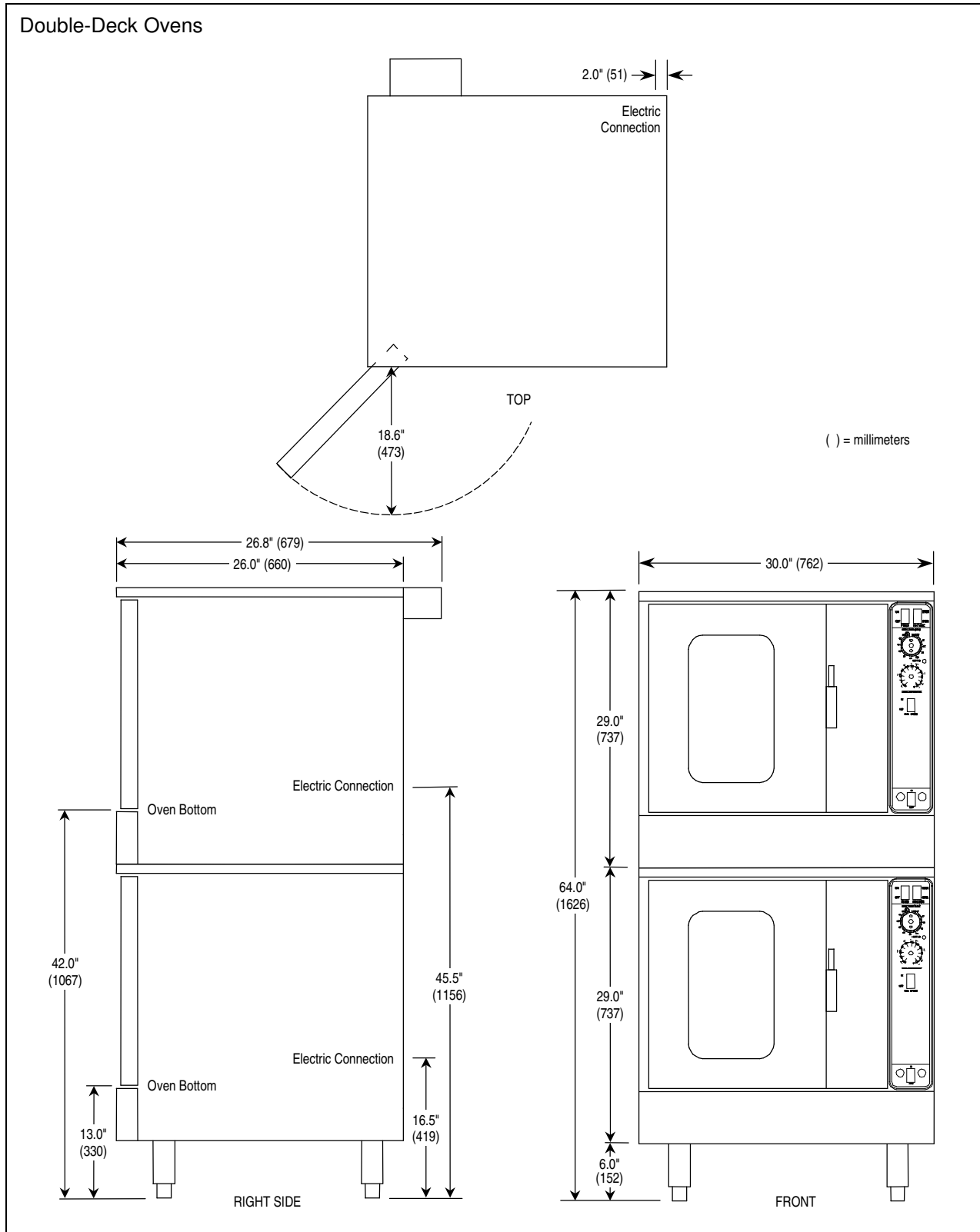

Model Number	Oven Interior			Pan Clearance		Shipping Crate				
	width	depth	height	width	depth	width	height	depth	volume	weight
EH-20	15.8" (400)	21.3" (540)	20.0" (508)	13.0" (330)	21.0" (533)	55.0" (1397)	69.0" (1753)	45.5" (1156)	99.9 cu. ft. 2.83 cu. m	850 lbs 386 kg



**MINIMUM CLEARANCES**

**⚠ WARNING**

There must be adequate clearance between the left side of the ovens and combustible construction.

	Minimum Clearance from Combustible Construction	Minimum Clearance from Non-Combustible Construction
Back	0"	0"
Right Side	0"	0"
Left Side	2"	0"
Floor	0"	0"

Adequate clearance must be provided in the aisle to allow the doors to open sufficiently to permit the removal of the racks and for serviceability.

Although no clearance on the back due to heat is required, care must be taken to provide adequate air circulation into the rear of the compartment that contains the blower, which is on the right side of the oven.

Do not locate the oven adjacent to any high heat or grease-producing piece of equipment, such as a range top, griddle, fryer, etc., that could allow radiant heat to raise the exterior temperature of the oven above 130 °F (54 °C). **DO NOT MOUNT ABOVE OTHER COOKING EQUIPMENT.**

**VENTILATION**

**NOTICE**

Proper ventilation is the owner's responsibility. Any problem due to improper ventilation will not be covered by the warranty.

If a ventilation canopy is used, it is recommended that a canopy extend 6" past the appliance and that the bottom edge be located 6'6" from the floor. Filters should be installed at an angle of 45° or more from the horizontal. This position prevents dripping grease and facilitates collecting the run-off grease in a drip pan, unusually installed with a filter.

If an exhaust fan is used, it should be installed at least 2" above the flue opening at the top of the unit. A strong exhaust fan tends to create a vacuum in the room. Fresh air openings approximately equal to the fan area will relieve such a vacuum. In case of unsatisfactory performance on any appliance, check the appliance with the exhaust fan in the "OFF" position. Do this only long enough to check equipment performance. Then turn the exhaust fan back on and let it run to remove any exhaust that may have accumulated during the test.



# INSTALLATION

## NOTICE

These installation procedures must be followed by qualified personnel or warranty will be void.

Local codes regarding installation vary greatly from one area to another. The National Fire Protection Association, Inc. states in its NFPA 96 latest edition that local codes are the “authority having jurisdiction” when it comes to installation requirements for equipment. Therefore, installations should comply with all local codes.

This appliance, when installed, must be electrically grounded in accordance with local codes, or in the absence of local codes, with the *National Electrical Code*, *ANSI/NFPA 70* or the *Canadian Electrical Code*, *CSA C22.2*, as applicable.

## Step 1: Unpacking

### IMMEDIATELY INSPECT FOR SHIPPING DAMAGE

All containers should be examined for damage before and during unloading. The freight carrier has assumed responsibility for its safe transit and delivery. If damaged equipment is received, either apparent or concealed, a claim must be made with the delivering carrier.

Apparent damage or loss must be noted on the freight bill at the time of delivery. The freight bill must then be signed by the carrier representative (Driver). If the bill is not signed, the carrier may refuse the claim. The carrier can supply the necessary forms.

A request for inspection must be made to the carrier within 15 days if there is concealed damage or loss that is not apparent until after the equipment is uncrated. The carrier should arrange an inspection. Be certain to hold all contents plus all packing material.

1. Cut banding straps and remove packing material.
2. Cut banding strap holding oven to wooden skid.
3. If you are installing 4" legs on a single-deck oven, go to Step 2a on this page.  
If you are installing 26" legs on a single-deck oven, go to Step 2b on the next page.  
If you are installing a double-deck oven, go to Step 2c on page 10

## Step 2a: Installation of 4" Legs on Single-Deck Models

1. Raise oven sufficiently to allow clearance for the legs to be attached. Use of a lift truck or other mechanical lifting means is recommended. For safety, “shore up” and support the oven with an adequate blocking arrangement strong enough to support the load. (If it is absolutely necessary to rest the oven on its side, rest it on its left side or back side. Take care to protect the finish on the left side, and to prevent the weight from resting on the motor on the back.)
2. Attach each leg to a bottom corner of the oven by screwing it into the appropriate threaded hole.
3. Lower the oven gently onto a level surface. Never drop or allow the oven to fall.
4. Use a level to make sure that the oven is level. Each leg can be screwed in or out to lower or raise each corner of the oven.



Step 2b: Installation of 26" Legs on Single-Deck Models

1. Raise oven sufficiently to allow clearance for the legs to be attached. Use of a lift truck or other mechanical lifting means is recommended. For safety, "shore up" and support the oven with an adequate blocking arrangement strong enough to support the load. (If it is absolutely necessary to rest the oven on its side, rest it on its left side or back side. Take care to protect the finish on the left side, and to prevent the weight from resting on the motor on the back.)
2. Attach the legs to the bottom corners of the oven using the provided machine screws, flat washers, and lock washers. Each leg is secured by four screws. The mounting holes are pre-drilled and threaded.
3. Screw into the bottom of each leg either an adjustable foot or a caster (depending on which option was ordered). If attaching casters, the two casters with brakes should be attached to the front legs.
4. Lower the oven gently onto a level surface. Never drop or allow the oven to fall.
5. Use a level to make sure that the oven is level. The adjustable feet can be screwed in or out to lower or raise each corner of the oven.

INSTALLATION

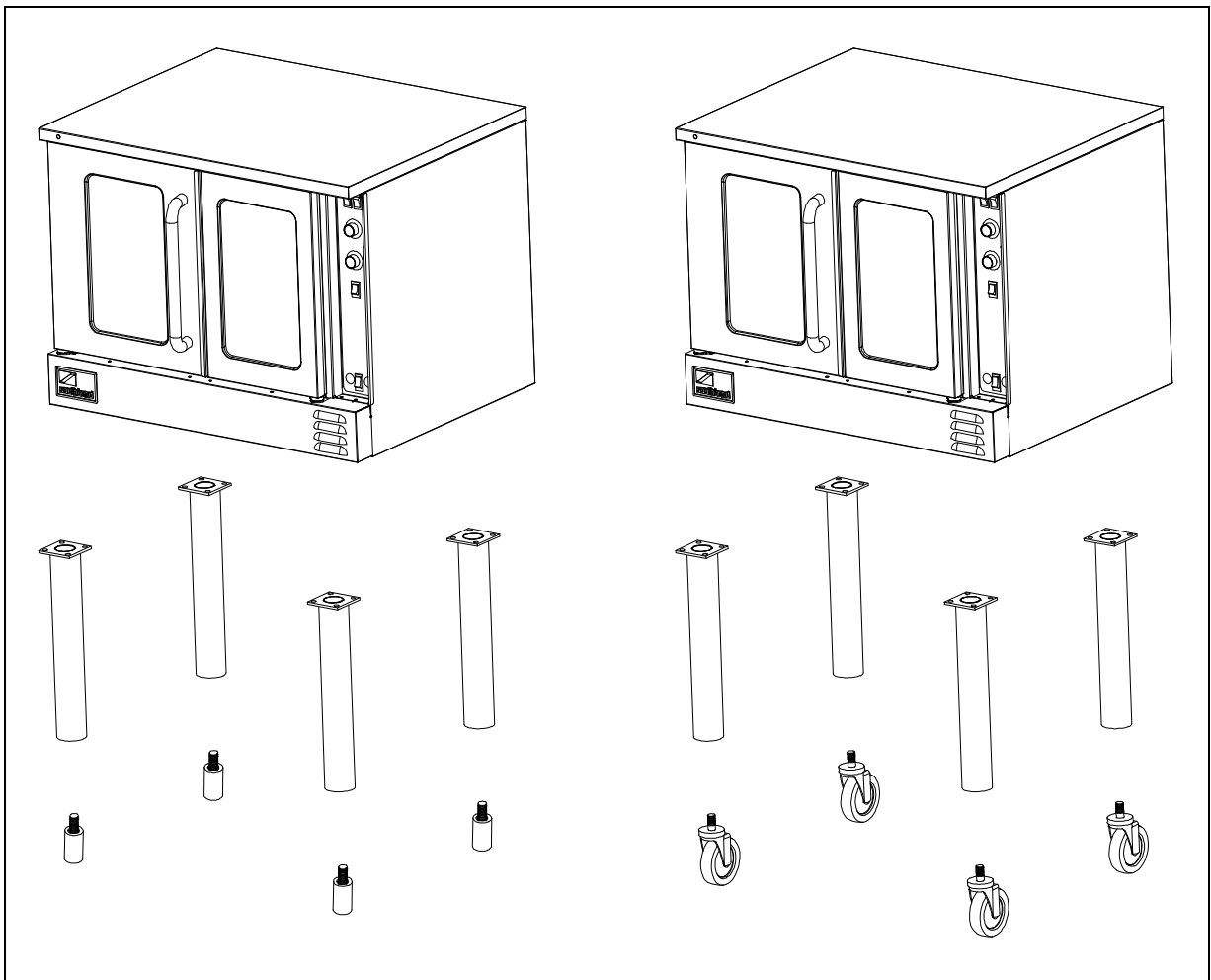



### Step 2c: Installation of Legs or Casters on Double-Deck Models

Double-deck oven can be shipped either already bolted together, or as two separate ovens to be bolted together after delivery. In either case, the oven that is (or will be) the lower oven will have leg pads already bolted to the bottom corners of the oven. Do the following:

1. Raise oven sufficiently to allow clearance for the legs to be attached. Use of a lift truck or other mechanical lifting means is recommended. For safety, "shore up" and support the oven with an adequate blocking arrangement strong enough to support the load. (If it is absolutely necessary to rest the oven on its side, rest it on its left side or back side. Take care to protect the finish on the left side, and to prevent the weight from resting on the motor on the back.)
2. Screw into the center of each leg pad either an adjustable leg or a caster (depending on which option was ordered). If attaching casters, the two casters with brakes should be attached to the front leg pads.
3. Lower the oven gently onto a level surface. Never drop or allow the oven to fall.
4. Use a level to make sure that the oven is level. The adjustable legs can be screwed in or out to lower or raise each corner of the oven.

INSTALLATION

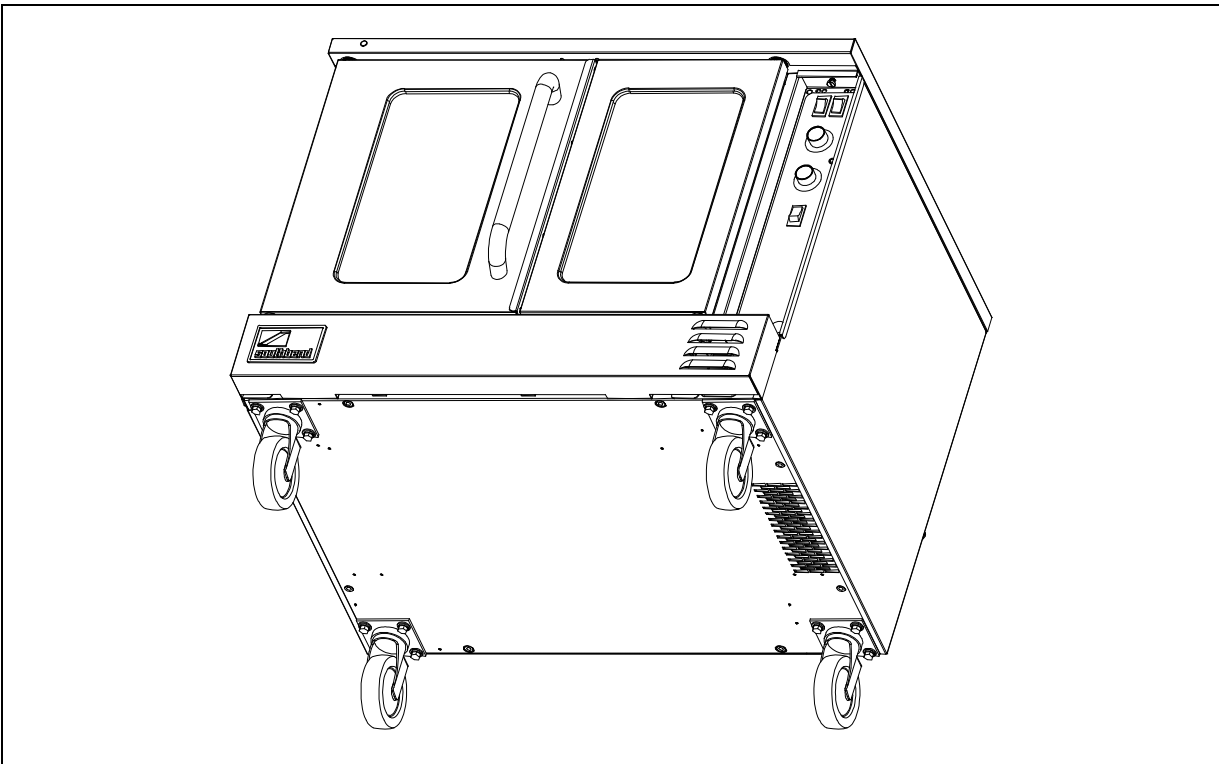



### Step 3: Stack Double-Deck Oven (if necessary)

Double-deck ovens can be shipped already assembled, but can instead be shipped as two single-deck ovens to be stacked in the field. Also, ovens that were originally ordered as single ovens can be stacked in the field (additional parts are required). This installation step describes the procedure for stacking two single-deck ovens to form a double-deck oven.

1. Uncrate the two ovens. Identify the oven that will be the lower oven (it will be the oven with leg pads attached to the bottom corners). Attach the legs (or casters) to the lower oven as described in Step 2b on page 10.
2. If the oven that will be the top oven was NOT ordered as part of a double-deck oven, remove the four leg pads from the bottom of the top oven.
3. Locate and remove the four screws that secure the lower front panel (items "A" in the drawing below). Lift up the panel and pull it forward to remove it, then set it aside.
4. Locate and remove the now-accessible screw that secures the lower front corner of the side panel.
5. Locate and remove the five screws that secure the right side panel to the oven (items "B" in the drawing below). Remove the right side panel and insulation and set them aside.

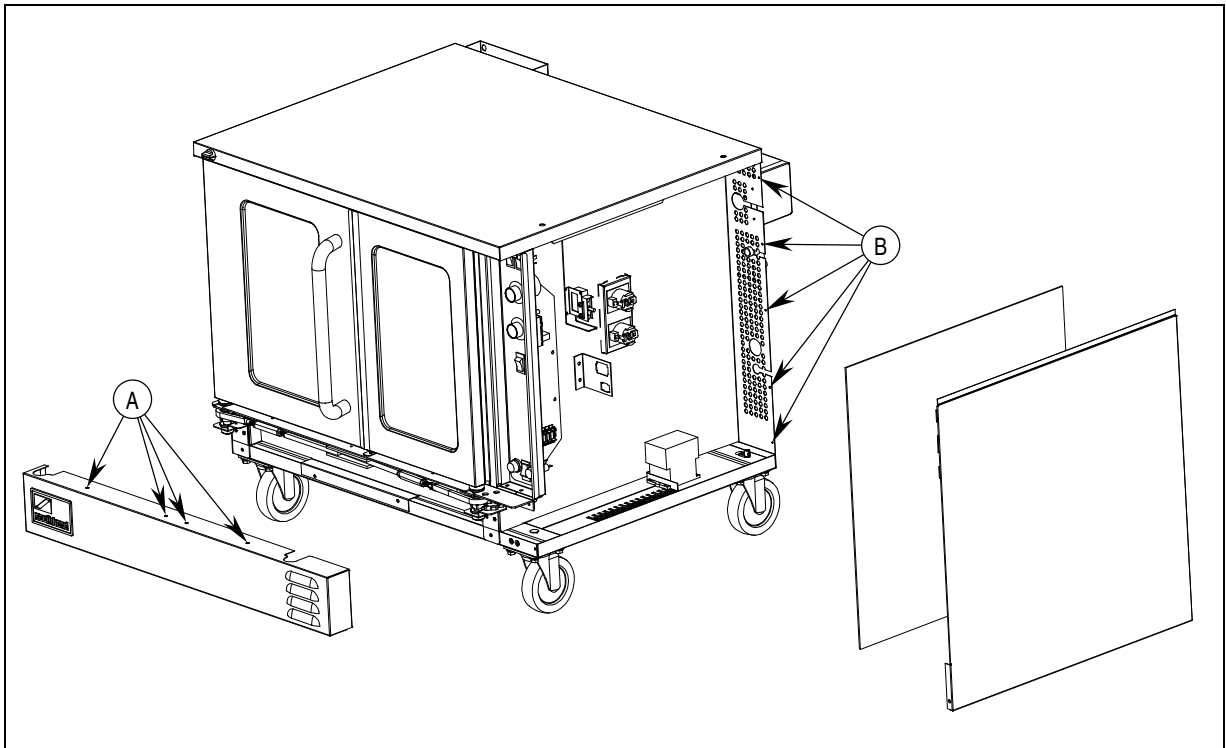



INSTALLATION

6. Lift the top oven and position it on top of the lower oven, as shown in the drawing below.

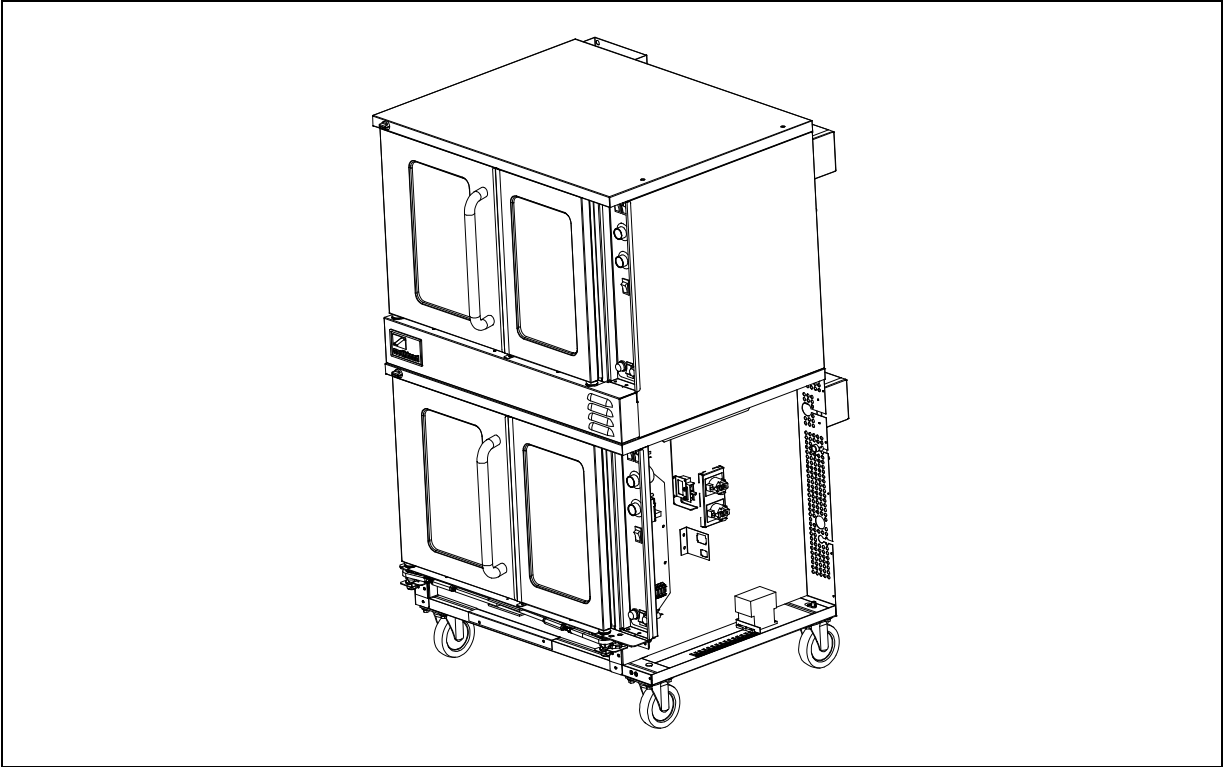

7. Move to the rear of the ovens and remove the six screws shown as items "A" in the left-hand drawing below. Position the tie bracket (item "B") as shown in the right-hand drawing below. Re-insert the screws that you just removed through the holes in the tie bracket, but do not tighten them yet.

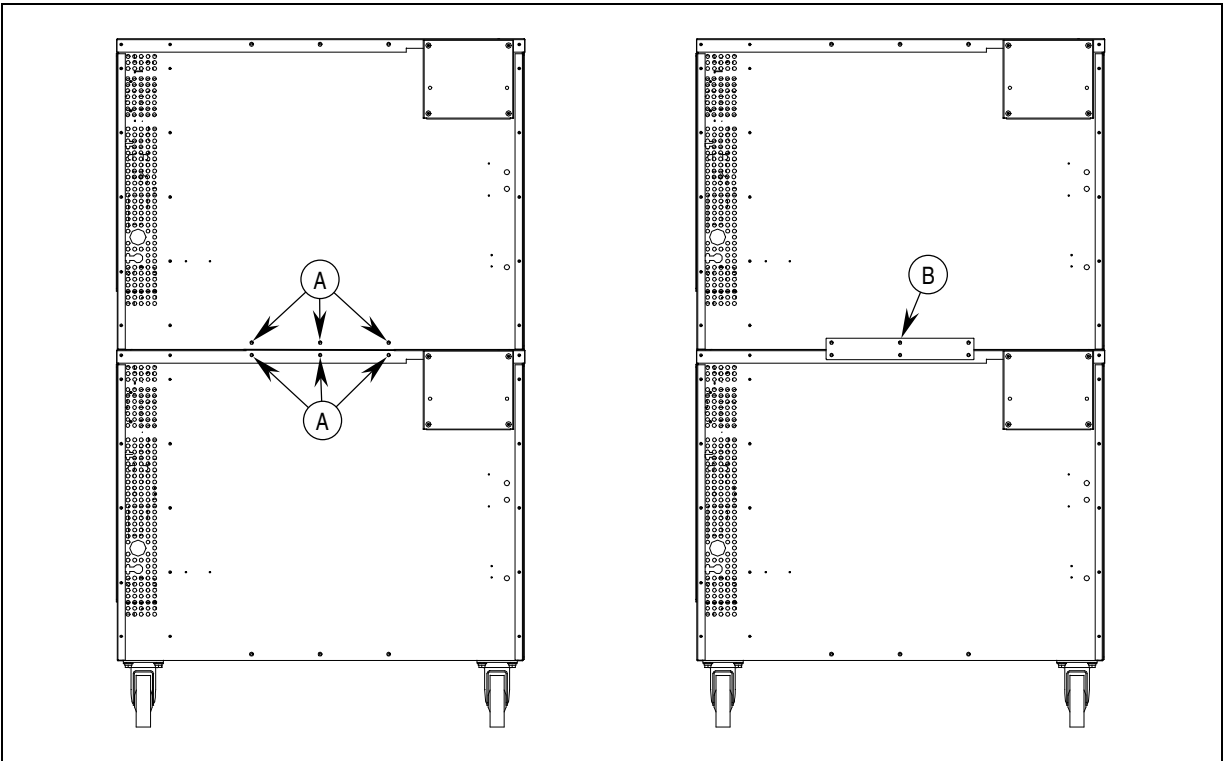



8. Insert two bolts (items "A" in the following diagram) up through the top of the lower oven and screw them into the threaded holes in the bottom of the top oven. Tighten these bolts and the screws that you did not tighten in the previous step.

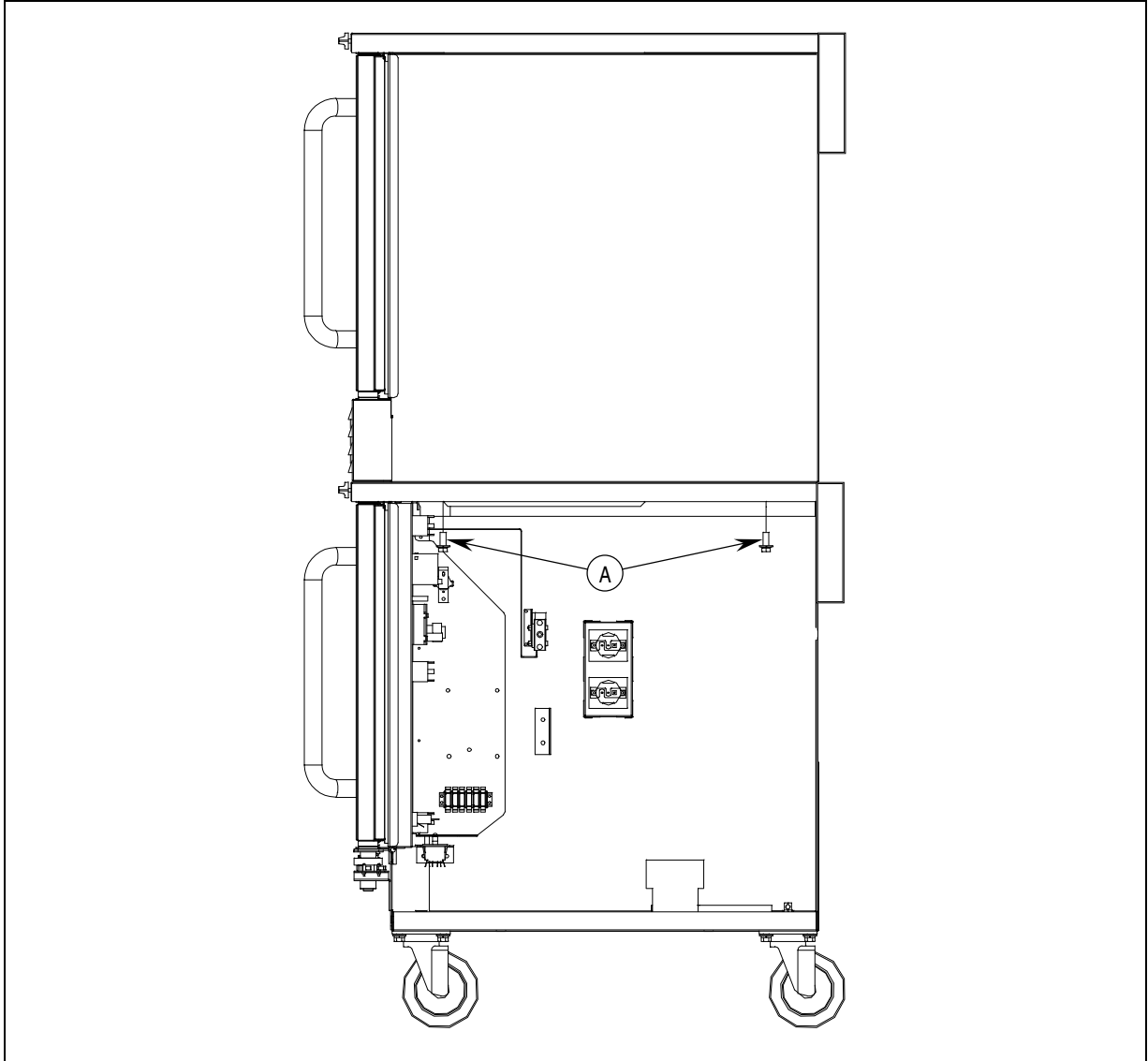

INSTALLATION

9. Replace the right side insulation, exterior panel, and lower front panel that you removed in steps 3, 4, and 5 of this procedure.



### Step 4: Installation of Optional Open Storage

The following describes how to assemble the optional open storage. All holes are pre-drilled for the provided screws.

1. Attach the legs to the oven as described in installation Step 2b on page 9.
2. Attach the two rack guides to the bottom of the oven using two clips and four screws for each rack (see figure "A" below).
3. Position the shelf below the rack guides and lift it so that the bottom ends of the rack guides pass through the holes in the shelf (see figure "B" below)
4. Secure the shelf to the rack guides with four clips, each secured by two screws that thread into the threaded holes on the shelf (see figure "C" below).
5. Attach the rack-stop using two screws. Attach the top of the rack stop to the bottom of the oven, and the bottom of the rack stop to the shelf (see figure "D" below).

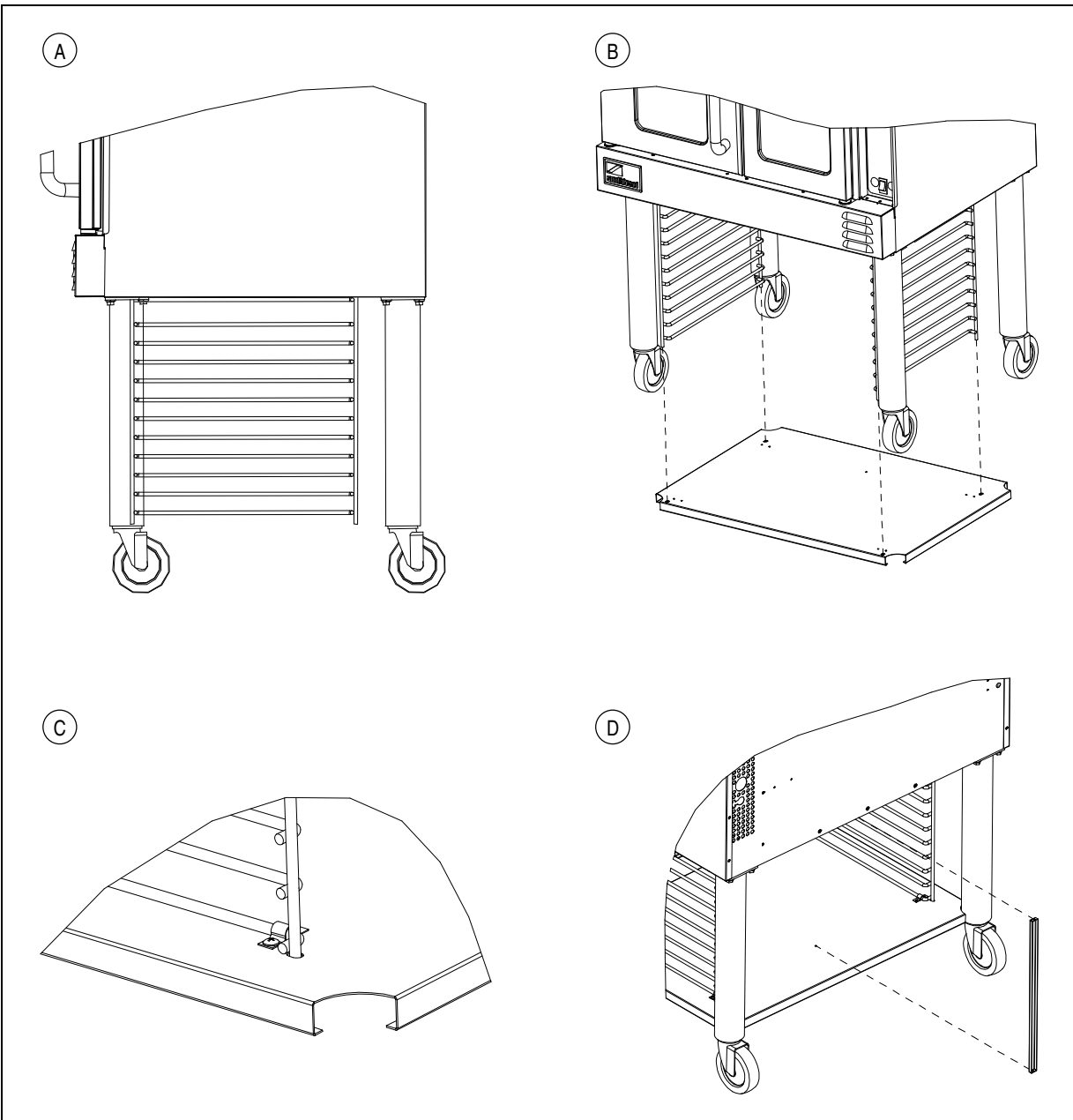



Step 5: Connect Electricity Supply

**! WARNING**

**ELECTRIC GROUNDING INSTRUCTIONS**

This appliance, when installed, must be electrically grounded in accordance with local codes, or in the absence of local codes, with the *National Electrical Code, ANSI/NFPA 70* or the *Canadian Electrical Code, CSA C22.2*, as applicable.

Ovens are shipped wired for either single-phase or three-phase power according to the original factory order. Wiring diagrams are located on the side of the control panel assembly, as well as in this manual (beginning on page 38). Be sure that the input voltage and phase match the requirements shown on the serial plate, which is located inside the lower front panel.

Conversion between single-phase and three-phase power can be performed in the field (see page 34).

The oven must be adequately grounded.

Use 167°F (75°C) wire for all supply lines.

The following drawing shows the locations of items referred to in the following procedure.

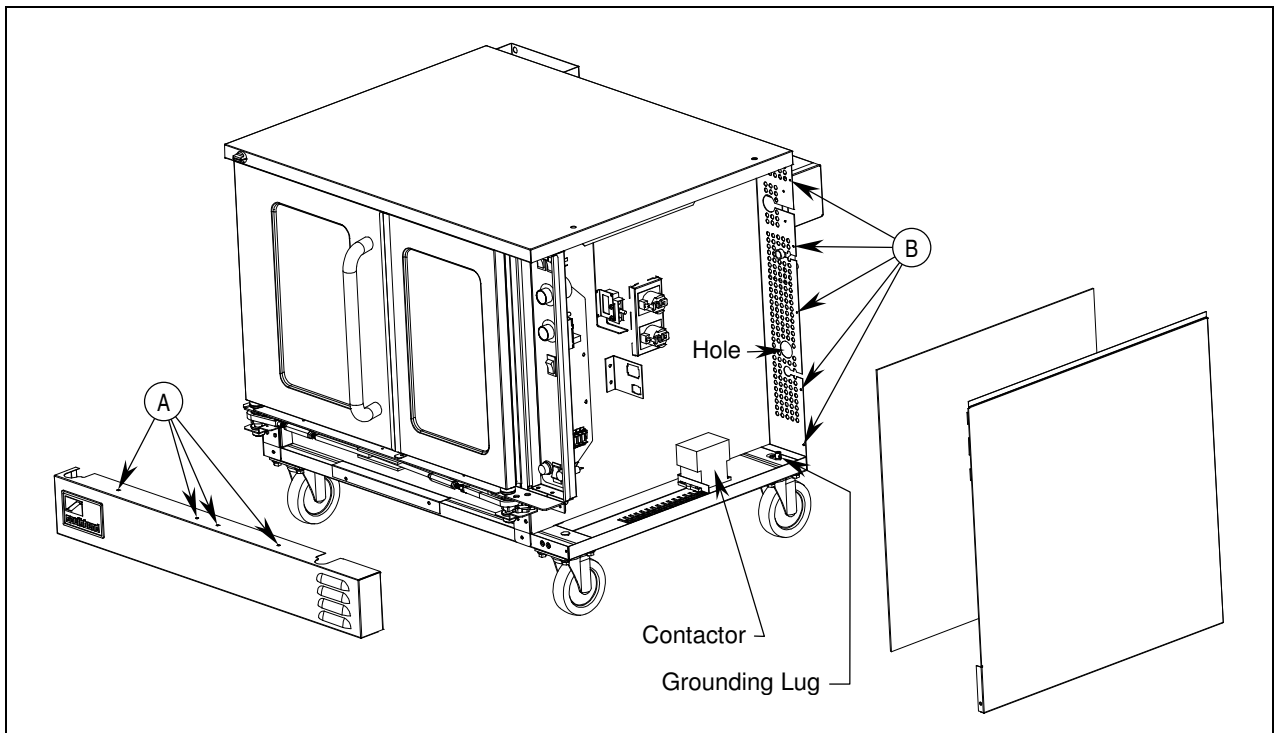

1. **CHECK THAT THE POWER SUPPLY CIRCUIT BREAKER IS OPEN.**
2. Locate and remove the four screws that secure the lower front panel (items "A" in the drawing above). Lift up the panel and pull it forward to remove it, then set it aside.
3. Locate and remove the now-accessible screw that secures the lower front corner of the side panel.
4. Locate and remove the five screws that secure the back edge of the side panel to the oven (items "B" in the drawing above). Remove the side panel and insulation and set them aside.
5. Route the supply wires and the grounding wire through the hole on the back of the oven. Use a strain-relief fitting.



6. Attach each supply wire to the appropriate terminal of the contactor (according to the wiring diagram).
7. Insert the ground wire into the grounding lug and tighten the screw.
8. Check that all connections match the wiring diagram and are tight.
9. Reattach the right-side panel and insulation; and the lower-front panel.

### Step 6: Check the Installation

1. Check that all screws and bolts are tightened.
2. Move the oven into the position at which it will be operated.
3. Check that the oven is level. If not, adjust the legs.
4. Check that the appropriate clearances are satisfied (see page 7).
5. Turn-on supply power and check oven for proper operation.



# OPERATION

## OPERATING THE CONTROLS

A convection oven is a different type of oven that offers many features and advantages to the food service operation. The additional capabilities and features of the oven require some learning. However, the operation of the oven is not difficult to understand or control once you have some practice.

Each oven will have one of the four types of control panels:

- Models with **Standard Controls** are the most similar to a standard (non-convection) oven. Instructions for operating this type of oven begin on page 18.
- Models with **Cycle/Cook and Hold Controls** enable you to have the oven automatically enter a “hold mode” after a timed cooking period. Instructions for operating this type of oven begin on page 20.
- Models with **Programmable Controls** enable you to have the oven change temperature and other settings while cooking, then optionally enter a “hold mode.” You can record up to five “cook programs” which can then be re-used later. Instructions for operating this type of oven begin on page 23.
- Models with **Rack Timer Controls** provide five separate timers that independently time the cooking of food on each rack of the oven. The oven will tell you which rack will finish cooking next, and how much time remains. Instructions for operating this type of oven begin on page 26.

OPERATION

## MOISTURE VENT

Each oven has a moisture vent that is opened and closed using the small knob located near the top left corner of the front panel of the oven (see illustration below). Usually the vent is kept open to allow moisture to escape. Close the vent (turn the knob clockwise) when doing fine baking.

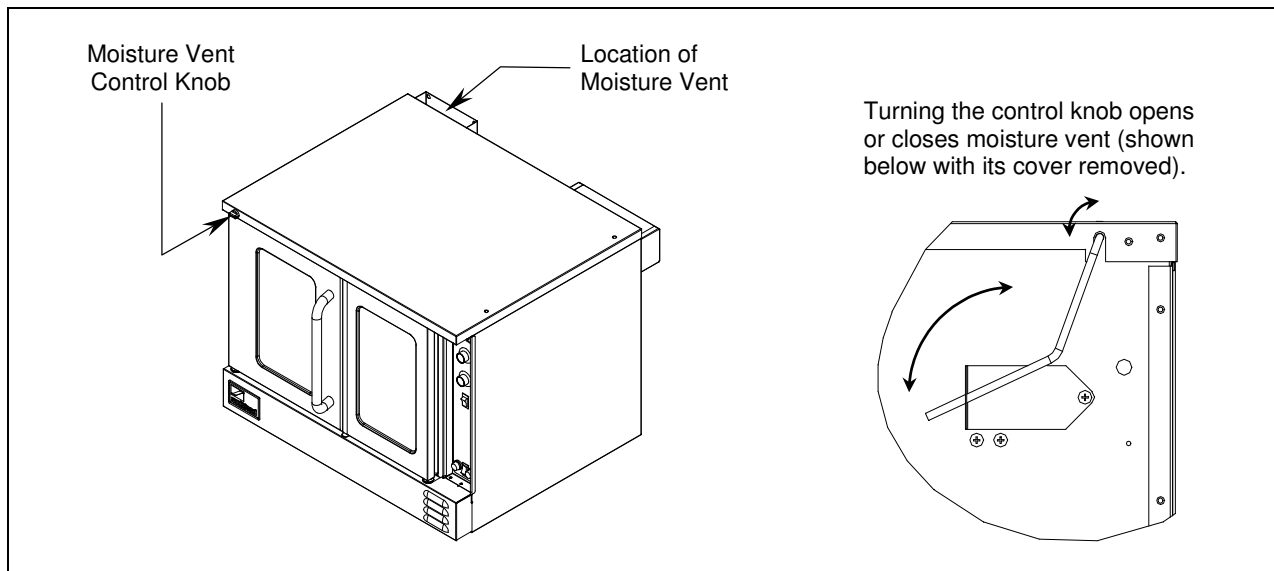



Control Panel of STANDARD Models

OPERATION

**Power Switch**

Switch ON to use the oven, switch OFF when done using the oven.

**Cook Timer**

Turn knob to set a time duration. An alarm will sound when the timer runs out. The timer is a reminder to the user; **the timer does not control the oven.**

**Cook Temperature Control**

Turn knob to select desired cooking temperature. The Heat On indicator will go out when the oven reaches the set temperature, and will cycle on and off as the burners operate to maintain the set cooking temperature.

**Oven Interior Light Switch**

On ovens equipped with an oven interior light, press to turn on the light. The light remains on for as long as the switch is held.

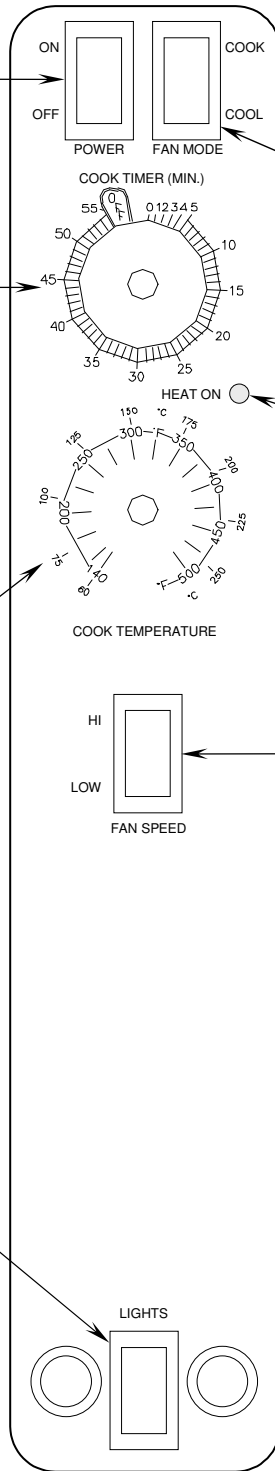

**Fan Mode**

In COOK mode, the fan runs continuously except when the doors are open. The fan does NOT cycle with the operation of the burners. In COOL mode, the fan runs continuously even if the doors are open. Since the burners will not operate if the oven doors are open, to rapidly cool the oven after cooking is completed, open the doors and switch the fan mode to COOL.

**Heat-On Indicator**

Indicator is lit when the burners are operating.

**Fan Speed**

Use to select fan speed (HI or LOW). The appropriate speed is determined by the type of food being cooked.



## Operation of STANDARD Models

Models with Standard Controls operate much like a standard oven: you turn the oven ON and select a cooking temperature. Two additional controls are used to control the fan (as described below).

The timer is a reminder to you of when to remove food from the oven. **The timer does NOT control the temperature of the oven.**

To cook, do the following:

1. Turn the oven ON using the Power Switch at the top of the control panel.
2. Select the desired fan speed using the Fan Speed switch. The appropriate fan speed (HI or LOW) depends on the type of food being cooked.
3. Switch the Fan Mode switch to COOK. The fan will run continuously when the oven doors are closed (the fan does not cycle on and off with the burners). (If this switch is set to COOL the only difference is that the fan will continue to run when the oven doors are open.)
4. Set the cooking temperature by turning the Cook Temperature Control until the indicator mark on the knob is pointed to the desired cooking temperature. The Heat On indicator will light when the burners are on, and will remain on while the oven preheats.
5. Wait until the Heat On indicator has come on and gone out three times. At that time the oven will have reached the set cooking temperature.
6. Open the oven doors, load the product into the oven, and close the doors.
7. You can use the Cook Timer as a reminder of when to remove the load from the oven. If so desired, turn the Cook Timer knob until the indicator mark points to the desired cooking time (up to 55 minutes). The timer knob will rotate counterclockwise as the timer runs down, indicating how much time remains. You can turn the knob while cooking to increase or decrease the remaining time. When the timer runs out, a buzzer will sound for a short time, then turn itself off. (To immediately silence the buzzer, turn the Cook Timer knob to the OFF position.) The timer is a reminder to you; **the timer does not control the oven.**

If you open the oven doors, the burners and fan will shut off until the doors are closed. However, the timer will continue running even if the doors are open.

For ovens that are equipped with an oven interior light, to turn on the light press and hold the switch located at the bottom of the control panel.

8. When the load has finished cooking, you can rapidly cool the load by opening the oven doors (which will shut off the burners) and switching the Fan Mode to COOL (which will cause the fan to run even though the doors are open). For the most rapid cooling, also switch the Fan Speed switch to HI.
9. When you are done cooking, turn the Cook Temperature control to the lowest setting (fully counterclockwise) and switch the Power Switch to OFF.



## Control Panel of CYCLE/COOK and HOLD Models

OPERATION

### Power Switch

Switch ON to use the oven, switch OFF when done using the oven.

### Time Display

Displays time setting. Indicator lights indicate whether the numbers shown represent hours-and-minutes or minutes-and-seconds.

### Temperature Display

Displays cook-temperature setting.

### Heat-On Indicator

Indicator is lit when the burners are operating.

### Hold Mode Indicator

Lights when Hold mode has been enabled.

### Hold Mode Button

Press to toggle Hold Mode on or off. To set the Hold temperature, press and hold this button while adjusting the temperature.

### Cook Start/Stop Button

Press to start a timed cook period whose duration is shown in the TIME window. During a timed cook period, the TIME window displays the remaining time. To stop cooking, press this button again.

### Oven Interior Light Switch

On ovens equipped with an oven interior light, press to turn on the light. The light remains on for as long as the switch is held.

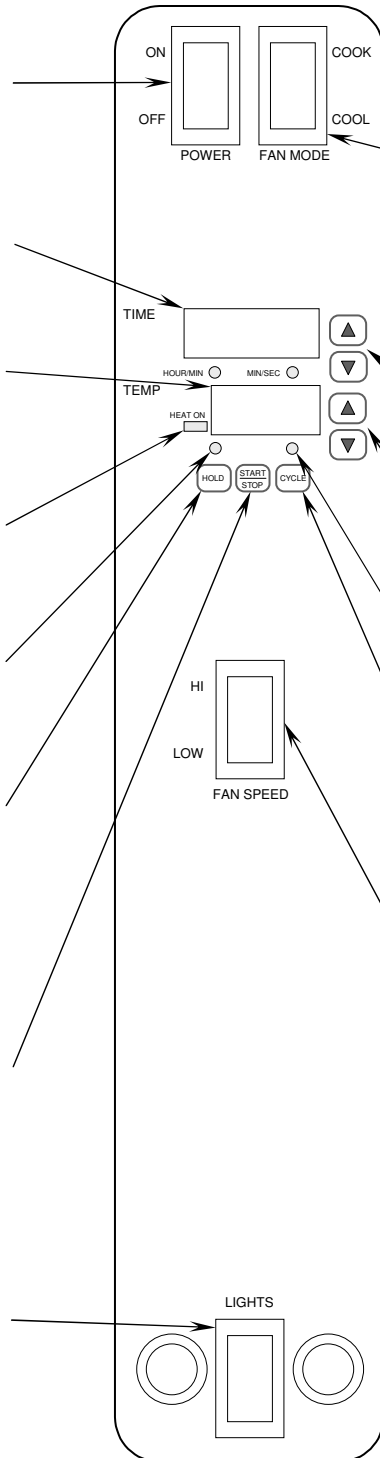

### Fan Mode

In COOK mode, the fan runs except when the doors are open. The fan does NOT cycle with the operation of the burners. In COOL mode, the fan runs continuously even if the doors are open. Since the burners will not operate if the oven doors are open, to rapidly cool the oven after cooking is completed, open the doors and switch the fan mode to COOL.

### Timer Adjustment Buttons

Press the up-arrow button to increase the time setting; press the down-arrow button to decrease the time setting.

### Temperature Adjustment Buttons

Press the up-arrow button to increase the temperature setting; press the down-arrow button to decrease the temperature setting.

### Fan Cycle Indicator

When on continuously the fan will run continuously. When flashing, fan will cycle on-and-off.

### Fan Cycle Button

Press to select whether the fan runs continuously, or cycles on and off.

### Fan Speed Switch

Use to select fan speed (HI or LOW). The appropriate speed is determined by the type of food being cooked.



## Operation of CYCLE/COOK and HOLD Models

CYCLE/COOK and HOLD models have electronic controls that enable the oven to cook food at a specified cook-temperature for a specified time period, then enter an optional Hold Mode during which the oven maintains a specified hold-temperature for an indefinite period of time.

Whenever the power switch is on, the oven will be in one of two modes. In **Cook Mode**, the oven maintains the specified cook temperature and the fan runs continuously, unless the Cycle option is enabled, in which case the fan cycles (on for 30 seconds, then off for 30 seconds). In **Hold Mode**, the oven maintains the specified hold-temperature and the fan runs only when the burners are on. (However, whenever the Fan Mode switch is in the COOL position, the fan will run continuously.)

To cook, do the following:

1. Turn the oven ON using the Power Switch at the top of the control panel. The oven will be in Cook Mode, and will begin to heat to the temperature displayed in the temperature display window.
2. Set the desired cook-temperature (from 150°F to 500°F) by pressing the up-arrow and/or down-arrow buttons to the right of the temperature display window. The temperature display will flash while the oven preheats. The Heat On indicator will light when the burners are on. To view the actual oven temperature at any time, press the up-arrow and down-arrow buttons simultaneously.
3. Switch the Fan Mode switch to the COOK position (if it is not already in that position). The fan will run when the oven doors are closed (the fan does not cycle on and off with the burners). (If this switch is set to COOL the only difference is that the fan will continue to run when the oven doors are open.)
4. Select whether you want the fan to cycle during cooking by pressing the Cycle button. If the Cycle indicator light is on continuously, the fan will run continuously. If instead the Cycle indicator light is flashing, the fan will cycle on for 30 seconds and then off for 30 seconds while cooking. Fan cycling is used for delicate products such as meringues and muffins which need to set, and is usually combined with the LOW fan speed (selected in the next step).
5. Select the desired fan speed by pressing the Fan Speed switch. The appropriate fan speed (HI or LOW) depends on the type of food being cooked.
6. Select the desired cooking time by pressing the up-arrow and/or down-arrow buttons to the right of the time display window. Holding down a button will speed-up the rate at which the displayed value changes. Lights under the displayed time indicate if the displayed time is in minutes-and-seconds or in hours-and-minutes. The time setting will not start counting down until you tell the oven to start cooking (in Step 9).
7. If you want the oven to enter a lower-temperature Hold Mode after a timed cook period, press and hold down the Hold button. The temperature display will now show the oven temperature (140°F to 200°F) desired during the hold mode. You can change the desired holding temperature using the up-arrow and down-arrow buttons to the right of the temperature display window (while holding down the Hold button). If you want the oven to enter Hold Mode after the cook time, be sure that the Hold Mode Indicator is lit (if it is not, press and release the Hold button so that it becomes lit). Note that when Hold Mode starts the actual oven temperature will not immediately drop to the holding temperature since it takes time for the oven interior and the load itself to cool.

### CAUTION

Care should be exercised in holding products over extended periods of time or at very low holding temperatures, due to possible bacteria growth. A competent authority on food bacteria growth should be consulted if there is doubt regarding safe holding times and temperatures.

8. Wait until the oven has reached cooking temperature (when it does, the temperature display will stop flashing and the oven will “beep” once).
9. Open the oven doors and insert a load into the oven. Close the doors and press the Start/Stop button. The oven will enter Cook Mode and the time display will start to count down the remaining cook time.



If you open the oven doors, the fan and burners will temporarily shut off, and the time display will pause until the oven doors are closed again.

For ovens that are equipped with an oven interior light, to turn on the light press and hold the switch located at the bottom of the control panel.

During the cook time you can start or stop having the fan cycle on-and-off by pressing the Cycle button.

If necessary, you can adjust the remaining cooking time and/or oven temperature using the corresponding up-arrow and down-arrow buttons. You can also disable or enable Hold Mode.

To cancel a timed-cook, press the Start/Stop button.

10. What happens when the cook time runs out depends on whether Hold Mode is enabled.
- If Hold Mode IS NOT enabled, the oven will start “beeping” and the time display will flash “:00”. Press the Start/Stop button to silence the alarm and the oven will return to Cook Mode. Promptly remove the load from the oven OR open and leave open the oven doors. **If the oven doors are shut, the oven will maintain the set cook temperature even though the timer has run out.** To rapidly cool down the load, open the doors, switch the Fan Mode switch to COOL, and switch the Fan Speed switch to HI.
  - If Hold Mode IS enabled, the oven will beep 3 times to alert you that the cook time has completed. The time display will start counting up to indicate how long the load has been in Hold Mode (up to 99 hours). The temperature display will change to show the holding temperature (set in Step 7) and the burners will remain off while the oven gradually cools to the holding temperature. With the doors closed, the oven will maintain the set holding temperature until you press the Start/Stop button (usually after removing the load). Pressing the Start/Stop button returns the oven to Cook Mode, and the oven will then heat up to the specified cook temperature in anticipation of the next load to be cooked.
11. When you are done cooking, switch the Power Switch to OFF.



Control Panel of PROGRAMMABLE Models

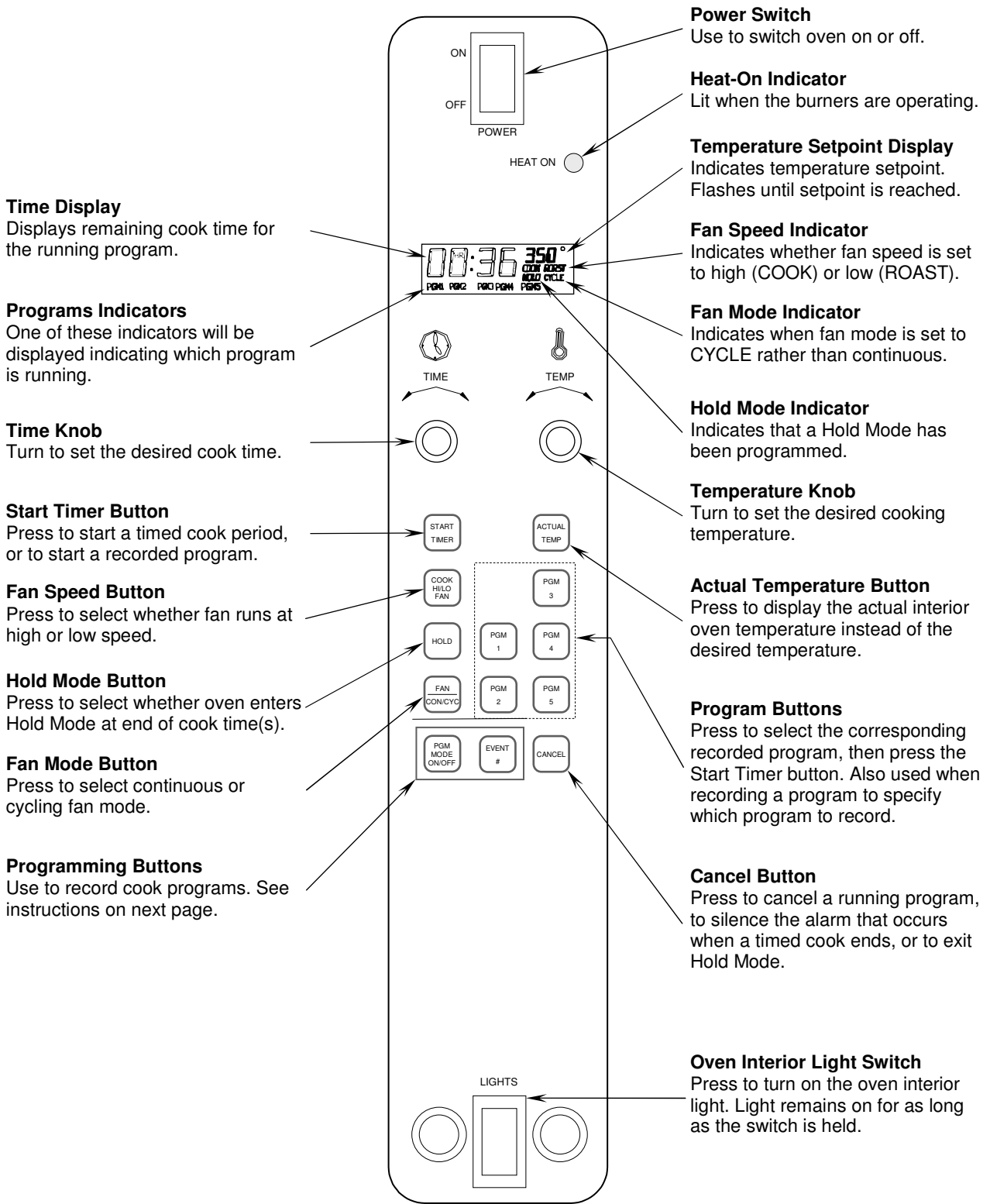

OPERATION



## Operation of Models with PROGRAMMABLE Controls

Models with Programmable Controls can follow a recorded sequence of timed cooking periods, with an option of the last period being an indefinite hold time. Each time period begins with an “event” that specifies what conditions will be maintained during the period that follows.

To cook WITHOUT using a recorded cook program, do the following:

1. Turn the oven ON using the Power Switch at the top of the control panel.
2. Set the cooking temperature by turning the Temperature Knob. The setting appears in the top right corner of the control panel display. The displayed temperature will flash while the oven preheats.
3. Select the desired fan speed during cooking by pressing the Cook Hi/Lo Fan button. The setting (COOK for high fan speed or ROAST for low fan speed) appears in the control panel display just below the temperature setting. The appropriate fan speed depends on the type of food being cooked.
4. Select the desired fan mode by pressing the Fan Cont/Cyc button. The setting appears in the control panel display just below the fan speed setting. In continuous mode (CONT), the fan will run when the power switch is ON and the doors are closed. In cycle mode (CYCLE), the fan will run only when the doors are closed and the burners are operating.
5. Turn the Time knob until the desired cooking time appears on the control panel display.
6. If you want the oven to enter Hold Mode after the timed cook period, press the Hold button. The Hold indicator (the word “HOLD” in the control panel window) will appear. Turn the Temperature knob until the desired holding temperature is displayed. Select a fan mode for the hold time by pressing the Fan Cont/Cyc button (as you did for the cook time in Step 4). The fan speed is always low during Hold Mode. Note that when Hold Mode starts the actual oven temperature will not immediately drop to the holding temperature since it takes time for the oven interior and the load itself to cool.

### CAUTION

Care should be exercised in holding products over extended periods of time or at very low holding temperatures, due to possible bacteria growth. A competent authority on food bacteria growth should be consulted if there is doubt regarding safe holding times and temperatures.

7. Wait until the oven has reached cooking temperature (when it does, the temperature display will stop flashing and the oven will “beep” once).
8. Open the oven doors and insert a load into the oven. Close the doors and press the Start Timer button. The time display will start to count down the remaining cook time.  
If you open the oven doors, the fan and burners will temporarily shut off, and the time display will pause until the oven doors are closed again.  
To turn on the oven interior light, press and hold the switch located at the bottom of the control panel.  
During the cook time you can start or stop having the fan cycle on-and-off by pressing the Cycle button.  
If necessary, you can adjust the remaining cooking time and/or oven temperature using the corresponding control knobs. You can also disable or enable Hold Mode.  
To cancel a timed-cook, press the Cancel button.
9. What happens when the cook time runs out depends on whether Hold Mode is enabled.
  - If Hold Mode IS NOT enabled, the oven will start “beeping” and the time display will flash “:00”. Press the Cancel button to silence the alarm. Promptly remove the load from the oven OR open and leave open the oven doors. **If the oven doors are shut, the oven will maintain the set cook temperature.** To rapidly cool down the load, open the doors, switch the Fan Mode switch to COOL, and switch the Fan Speed switch to high (COOK).
  - If Hold Mode IS enabled, the oven will beep for 2 or 3 seconds to alert you that the cook time has completed. The time display will start counting up to indicate how long the load has been in Hold Mode. Later, after removing the load, press the Cancel button. **The oven will then heat up to the specified cook temperature in anticipation of the next load to be cooked.**



10. When you are done cooking, switch the Power Switch to OFF.

To RECORD a cook program to use later, do the following:

1. Press the Program Mode On/Off button.
2. Select which program you want to record by pressing the corresponding program button (PGM1, PGM2, PGM3, PGM4, or PGM5). The bottom line of the control panel display will indicate which program is being recorded. The temperature display will alternately flash the temperature setting and the event number being set (e.g., "E1," "E2"). Set a temperature, time duration, fan mode, and fan speed for the event, then press the Event # button to go on to the next event of the program.
3. Repeat Step 2 for each event in the program. Programs 1 and 2 can each have up to six events, while programs 3, 4, and 5 can each have up to four events. If the last event will be to enter Hold Mode, when you get to that event press the Hold button, then set a temperature and fan mode.

To check the program, you can step through the events by pressing the Event # button. The event number being shown will flash alternately with the temperature display, and the other control settings for the event will also be shown in the control panel window.

4. When you have entered the last event you want the program to include, press the Program Mode On/Off button. (If you have checked the program by stepping through the events with the Event # button, make sure that the last event that you want included in the program is being displayed before you press the Program Mode On/Off button. Any subsequent events in the program left over from an earlier program recording will be erased.)

To COOK using a cook program that you have recorded, do the following:

1. Turn the oven ON using the Power Switch at the top of the control panel.
2. Press the Program button (PGM1, PGM2, PGM3, PGM4, or PGM5) of the program that you want the oven to follow. The number of the program will appear on the bottom line of the control panel display.
3. Wait until the oven has reached cooking temperature (when it does, the temperature display will stop flashing and the oven will "beep" once).
4. Open the oven doors and insert a load into the oven. Close the doors and press the Start Timer button. The time display will start to count down the remaining cook time of the time period after the first event. As each subsequent cook event occurs, the control panel display will change to the settings that you programmed, and the time display will count down to the next event.

If you open the oven doors, the fan and burners will temporarily shut off, and the time display will pause until the oven doors are closed again.

To turn on the oven interior light, press and hold the switch located at the bottom of the control panel.

During the cook time you can start or stop having the fan cycle on-and-off by pressing the Cycle button.

To cancel a cook program, press the Cancel button.

5. What happens when the program's last cook period ends depends on whether the last event of the program is to enter Hold Mode.
  - If the last event of the program is a cook event (NOT to enter Hold Mode), when the program ends the oven will start "beeping" and the time display will flash ":00". Press the Cancel button to silence the alarm. Promptly remove the load from the oven OR open and leave open the oven doors. **If the oven doors are shut, the oven will maintain the cook temperature that was in effect before the program was started.** To rapidly cool down the load, open the doors, switch the Fan Mode switch to COOL, and switch the Fan Speed switch to high (COOK).
  - If the last event of the program IS to enter Hold Mode, when the last cook period ends the oven will beep for 2 or 3 seconds to alert you that the cooking has completed. The time display will start counting up to indicate how long the load has been in Hold Mode. Later, after removing the load, press the Cancel button. **The oven will then heat up to the cook temperature that was in effect before the program was started.**
6. When you are done cooking, switch the Power Switch to OFF.



Control Panel of RACK TIMER Models

OPERATION

**Time Display**

Displays remaining time for the rack with the least remaining cook time. When the timer runs out, the display will show the rack number of the rack which has timed out.

**Racks-Being-Timed Indicators**

Rack timers are running for the indicated racks. The name of the rack that will next finish will flash.

**Time Knob**

Turn to set the desired cook time.

**Timer Buttons**

Used to preset frequently used cooking times. To assign a time duration to one of these buttons, hold down the button and turn Timer Knob. Then to start a rack timer using that time duration, press the Timer Button and then press the appropriate Rack Button.

**Rack Buttons**

Press to start the timer of the corresponding rack (after specifying a time duration using either the Time Knob or a Timer Button).

**Oven Interior Light Switch**

Press to turn on the oven interior light. Light remains on for as long as the switch is held.

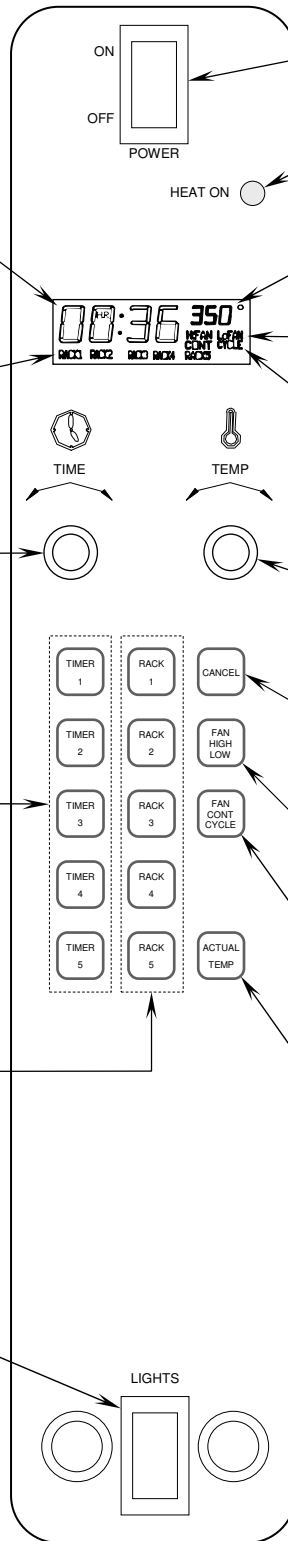

**Power Switch**

Use to switch oven on or off.

**Heat-On Indicator**

Lit when the burners are operating.

**Temperature Setpoint Display**

Indicates temperature setpoint. Flashes until setpoint is reached.

**Fan Speed Indicator**

Indicates fan speed is set to either High or Low.

**Fan Mode Indicator**

Indicates whether fan is set to run continuously (CONT) or to cycle on and off with the burners (CYCLE).

**Temperature Knob**

Turn to set the desired cooking temperature.

**Cancel Button**

Press to silence the beeping that starts when a timer runs out. To cancel a running timer, press the corresponding Rack Button, then press this button.

**Fan Speed Button**

Press to select whether fan runs at high or low speed.

**Fan Mode Button**

Press to select continuous or cycling fan mode.

**Actual Temperature Button**

Press to display the actual interior oven temperature instead of the desired temperature.



## Operation of RACK TIMER Models

Rack Timer models have five independent timers, one for each rack. After loading a rack, you can start a timer for that rack. The control panel displays which racks are being timed, which rack will be the next to time out, and how much time remains before that happens. Of course, the oven temperature, fan speed, and fan mode are the same for all racks.

You can manually set a cooking time each time you load a rack, or you can preset up to five time durations that you can then recall by pressing the corresponding Timer Button. To assign a time duration to a Timer Button, hold down the corresponding button (TIMER1, TIMER2, TIMER3, TIMER4, or TIMER5), turn the Time Knob to the desired time, and release the Timer Button. Step 6 below describes how to use these buttons to set a rack's timer.

The rack timers are reminders to you of when to remove pans from the oven. **The rack timers do NOT control the temperature of the oven.**

To cook using the rack timers, do the following:

1. Turn the oven ON using the Power Switch at the top of the control panel.
2. Set the cooking temperature by turning the Temperature Knob. The setting appears in the top right corner of the control panel display. The displayed temperature will flash while the oven preheats.
3. Select the desired fan speed by pressing the Fan High/Low Button. The setting (HiFAN or LoFAN) appears in the control panel display just below the temperature setting. The appropriate fan speed depends on the type of food being cooked.
4. Select the desired fan mode by pressing the Fan Cont/Cyc Button. The setting appears in the control panel display just below the fan speed setting. In continuous mode (CONT), the fan will run when the oven is ON and the doors are closed. In cycle mode, the fan will run only when the doors are closed and the burners are operating.
5. Wait until the oven has reached cooking temperature (when it does, the temperature display will stop flashing and the oven will "beep" once). To display the actual temperature in the oven at any time, press the Actual Temp button.
6. Open the oven doors and insert a pan onto a rack. Close the doors and then either turn the Timer Knob until the desired cooking time appears on the control panel display, OR press the Timer Button that corresponds to a preset time that you have associated with that button. Finally, start the timer by pressing the Rack Button that corresponds to the just-loaded rack.

The time display will start to count down. The time display indicates the time remaining until the next time-out of a rack timer will occur. To display the time remaining for any rack, press the corresponding Rack Selector button. You can add additional pans at any time. The timer for each rack works independently.

The bottom line of the control panel display indicates which racks are presently being timed (RACK1, RACK2, RACK3, RACK4, and/or RACK5). The one that is flashing indicates which rack is the next one that will time out.

If you open the oven doors, all rack timers pause until the oven doors are closed again.

To turn on the oven interior light, press and hold the switch located at the bottom of the control panel.

To cancel any rack's timer (if, for example, you see that the food on that rack has finished cooking), press the corresponding Rack Button, then press the Cancel button.

7. When a rack's timer runs out, the time display will change to display a number corresponding to the rack that is done, and the control panel will "beep" repeatedly. Press the Cancel Button. If the oven continues to beep and the display shows another rack number, it means that rack's timer has also timed out. Press the Cancel Button until the oven stops beeping, noting which racks have timed out. Open the oven doors and remove the pan(s) from the timed-out rack(s). If you have more pans to be cooked, put them on the now empty rack(s) and set the rack's timer as appropriate (see Step 6).



# COOKING HINTS

In a standard (non-convection) oven, the air is relatively still and an insulating layer of moisture surrounds the cooking food product. In a convection oven, the fan-blown circulating air strips away this insulating layer allowing the heat to penetrate faster for quicker baking and roasting. Hence, in a convection oven cooking procedures and techniques may require some modification for successful results. As a general rule, the cooking time will be shorter and the cooking temperature will be 25°F to 75°F lower than those called for in recipes for a standard oven.

## TIME & TEMPERATURE

Time and temperature are important. The “Guide to Times and Temperatures” later in this section is a starting point. The actual best cooking time and temperature will depend on such factors as size of load and mixture of recipe (particularly moisture). Once an appropriate time and temperature has been established for a particular product and load, you will find the result of succeeding loads to be similar.

## OVERLOADING

Do NOT overload the oven. The size of the load that can be cooked satisfactorily depends largely on the particular product. As a rule, five racks can be successfully used for shallow cakes, cookies, pies, etc. For deeper cakes (such as angel food), use only three racks because of the size of the pan and the space required for rising. For hamburger patties, fish sticks, cheese sandwiches, etc., a full complement of racks and pans is usually satisfactory.

## HELPFUL SUGGESTIONS

Here are some suggestions that will assist in getting the best possible performance from a convection oven:

- Pre-heat the oven thoroughly before use.
- When re-thermalizing frozen products, pre-heat the oven to 50°F higher than the planned cooking temperature. After loading, reduce the temperature setting to the appropriate cooking temperature.
- Space the racks and pans as evenly as possible to allow air circulation.
- Center the load on the racks to allow for proper air circulation around the sides. Do not cover the racks completely with pans.
- Do not use a deep pan for shallow cakes or cookies, etc. Air circulation across the surface of the product is essential.

### **WARNING**

THE USE OF ALUMINUM FOIL CAN CAUSE HEAT DISTRIBUTION PROBLEMS IN OVENS. EXTREME CARE MUST BE USED WHEN PLACING ALUMINUM FOIL IN THE OVEN TO ENSURE THAT IT DOES NOT BLOCK OR CHANGE THE AIR FLOW. THE USE OF ALUMINUM FOIL MAY VOID THE PRODUCT WARRANTY IF ITS USE IS ASCERTAINED TO BE A PROBLEM.

## HOLDING FOOD BEFORE SERVING

Any food item prepared in steam table pans can be held until being served by setting the Hold thermostat to 160°F. Examples include stuffed pork chops, oysters Rockefeller, and any vegetable entree.

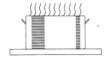

COOKING PROBLEMS AND SOLUTIONS

If...	then...
Cakes are dark on the sides and not done in the center...	lower oven temperature.
Cake edges are too brown...	reduce number of pans or lower oven temperature.
Cakes have a light outer color...	raise temperature.
Cakes settle slightly in the center...	bake longer or raise oven temperature slightly. Do not open doors except to load or unload product.
Cakes ripple...	do not overload pans or use batter that is too thin.
Cakes are too coarse...	lower oven temperature.
Pies have uneven color...	reduce number of pies per rack or eliminate use of bake pans.
Brown sugar topping or meringue blows off...	after oven is preheated, turn off oven and put product in oven until topping sets, then turn oven back on.
Rolls have uneven color...	reduce number or size of pans.
Meats are browned and not done in center...	lower oven temperature and roast longer.
Meats are well done and not browned...	raise temperature. Limit amount of moisture.
Meats develop hard crust...	reduce temperature or place pan of water in oven.
Excessive meat shrinkage occurs...	lower oven temperature.

COOKING HINTS

GUIDE TO TIMES AND TEMPERATURES

As a guide, set oven temperatures 25°F to 75°F lower than called for in recipes for non-convection ovens, (i.e., range or deck ovens).

Time and temperature will vary depending upon load, mix, size, portion, initial temperature of food, and other factors. Use the following chart as a starting point to develop your own cooking techniques. Rack loading and position may affect results. Experimentation may be necessary to suit individual requirements.

	Cooking Time	Temperature	Number of Racks
<b>Meat and Fish</b>			
Top Round, 18-20 lbs. (medium)	5 hours	225°F	1
Prime Ribs (rare)	4 hours	225°F	1
Burger Patties, 4 oz.	5 min.	350°F	5
Fish Cakes	10-12 min.	350°F	5
Turkey, 10-12 lbs.	3 hours	225°F	1



	Cooking Time	Temperature	Number of Racks
<b>Baked Goods</b>			
Bread, 2 lb. loaf	35 min.	375°F	3
Biscuits	5-10 min.	350°F	5
Cornbread	18 min.	400°F	5
French Bread	8 min.	375°F	5
Sheet Cake	15-18 min.	300°F	5
Cream Puffs	20 min.	325°F	5
Brown & Serve Rolls	5 min.	400°F	5
Ginger Bread	18 min.	300°F	5
Yeast Rolls, sheet pan	14-16 min.	325°F	5
Pineapple Upside Down Cake	25-30 min.	300°F	5
Apple Turnovers	15-18 min.	325°F	5
Fruit Cobbler	20-23 min.	350°F	5
Brownies	15 min.	350°F	5
Danish Pastry	12 min.	325°F	5
Pie Shells	12 min.	350°F	5
Fresh Fruit Pies	25-30 min.	350°F	5
Pumpkin Pies	25-30 min.	275°F	5
Fresh Apple Pies	35 min.	375°F	5
Frozen Berry Pies	40 min.	375°F	5
Frozen Fruit Pies	45 min.	375°F	5
<b>Potatoes</b>			
Baked Potatoes, 10 oz.	40-45 min.	450°F	5
Baked Potatoes, 6-8 oz.	30-35 min.	450°F	5
Scalloped Potatoes	28 min.	325°F	5
<b>Miscellaneous</b>			
Macaroni and Cheese	25 min.	350°F	5
Stuffed Peppers	18 min.	350°F	5
Toasted Cheese Sandwiches	8 min.	375°F	5



# CLEANING

Southbend equipment is sturdily constructed of the best materials and is designed to provide durable service when treated with ordinary care. To expect the best performance, your equipment must be maintained in good condition and cleaned daily. Naturally, the periods for this care and cleaning depend on the amount and degree of usage.

Following daily and periodic maintenance procedures will enhance long life for your equipment. Climatic conditions (such as salt air) may require more thorough and frequent cleaning or the life of the equipment could be adversely affected.

The oven interior is finished with a porcelain enamel coating. "Spillovers" should be cleaned from the interior bottom surface as soon as possible to prevent carbonizing and a burnt-on condition. Grease or any residue should be cleaned from interior surfaces as soon as it accumulates.

## **WARNING**

FOR YOUR SAFETY, DISCONNECT THE POWER SUPPLY TO THE APPLIANCE BEFORE CLEANING.

WHEN CLEANING THE BLOWER WHEEL, BE SURE TO HAVE THE POWER SWITCH IN THE "OFF" POSITION.

## DAILY CLEANING

1. Turn the power switch to OFF and allow the oven to cool.
2. Remove the oven-interior racks and rack slide frames. (The rack slide frames are readily removable by merely raising to disengage them from their sockets.) Wash the racks and rack slides in a sink with mild detergent and warm water. Dry them thoroughly with a clean cloth.
3. Look to see if any foreign matter has accumulated on the blades of the blower wheel (which will reduce air circulation). If necessary, remove the right-side lining of the oven, which is secured by thumbscrews near each corner. Use a stiff brush to remove accumulations from the blower blades, then wash with soap and water.
4. Wash the interior surfaces with mild detergent and warm water. Rinse with clean water, and dry thoroughly with a clean cloth. For stubborn accumulations, a commercial oven cleaner may be used.
5. Clean the control panel with warm water and mild soap. Never use cleaning solvents with a hydrocarbon base.
6. Wipe the other exterior surfaces with a clean damp cloth. If the exterior surfaces require more thorough cleaning, see "Cleaning Stainless Steel Surfaces" on the next page.
7. Return the rack slides and racks to their appropriate locations inside the oven.
8. LEAVE THE DOOR OPEN AT NIGHT AFTER CLEANING. This allows the oven to dry thoroughly after cleaning and also prolongs the life of the door gasket.

CLEANING

## MONTHLY CLEANING

Clean around the louvered panels on the front of the oven and the air holes on the rear of the oven where grease or lint may have accumulated.



## SEMIANNUAL CLEANING

At least twice a year have your Southbend Authorized Service Agency or another qualified service technician clean and adjust the unit for maximum performance.

At least twice a year the oven's venting system should be examined and cleaned.

## CLEANING STAINLESS STEEL SURFACES

To remove normal dirt, grease and product residue from stainless steel that operates at LOW temperature, use ordinary soap and water (with or without detergent) applied with a sponge or cloth. Dry thoroughly with a clean cloth.

To remove grease and food splatter, or condensed vapors, that have BAKED on the equipment, apply cleanser to a damp cloth or sponge and rub cleanser on the metal in the direction of the polishing lines on the metal. Rubbing cleanser, as gently as possible, in the direction of the polished lines will not mar the finish of the stainless steel. NEVER RUB WITH A CIRCULAR MOTION. Soil and burnt deposits which do not respond to the above procedure can usually be removed by rubbing the surface with SCOTCH-BRITE scouring pads or STAINLESS scouring pads. DO NOT USE ORDINARY STEEL WOOL, as any particles left on the surface will rust and further spoil the appearance of the finish. NEVER USE A WIRE BRUSH, STEEL SCOURING PADS (EXCEPT STAINLESS), SCRAPER, FILE OR OTHER STEEL TOOLS. Surfaces which are marred collect dirt more rapidly and become more difficult to clean. Marring also increases the possibility of corrosive attack. Refinishing may then be required.

**To remove heat tint** – Darkened areas sometimes appear on stainless steel surfaces where the area has been subjected to excessive heat. These darkened areas are caused by thickening of the protective surface of the stainless steel and are not harmful. Heat tint can normally be removed by the foregoing, but tint which does not respond to this procedure calls for a vigorous scouring in the direction of the polish lines, using SCOTCH-BRITE scouring pads or a STAINLESS scouring pad in combination with a powered cleanser. Heat tint action may be lessened by not applying, or by reducing heat to equipment during slack periods.



# ADJUSTMENTS

## WARNING

ADJUSTMENTS AND SERVICE WORK MAY BE PERFORMED ONLY BY A QUALIFIED TECHNICIAN WHO IS EXPERIENCED IN, AND KNOWLEDGEABLE WITH, THE OPERATION OF COMMERCIAL COOKING EQUIPMENT. HOWEVER, TO ASSURE YOUR CONFIDENCE, CONTACT YOUR AUTHORIZED SERVICE AGENCY FOR RELIABLE SERVICE, DEPENDABLE ADVICE OR OTHER ASSISTANCE, AND FOR GENUINE FACTORY PARTS.

## NOTICE

Warranty will be void and the manufacturer is relieved of all liability if service work is performed by other than a qualified technician, or if other than genuine Southbend replacement parts are installed.

## LUBRICATION

The door chains and sprockets have been lubricated at the factory with high temperature “Never Seeze” lubricant. After each six months of usage, lubricate the door chains and sprockets with the same type of lubricant.

Motor lubrication information can be found on permanent label located on motor.

Casters are provided with a Zerk fitting for proper lubrication when required.

## TEMPERATURE CONTROLLER (Standard-Control Models Only)

The calibration of the temperature controller should not be changed until sufficient experience with cooking results has definitely proved that the temperature controller is not maintaining proper oven temperatures. Before any recalibration is attempted, the oven temperature should be checked by the following procedure:

1. Remove all trays and pans from the oven.
2. Place a thermocouple or a reliable mercury oven-type thermometer at the center of the middle rack.
3. Turn the oven ON and set the temperature control knob to 400 °F.
4. The amber “heat on” light will go out when the oven temperature is reached.
5. Allow three cycles for the temperature to stabilize.
6. Read the thermocouple or thermometer immediately after the light goes out for the third time, and again immediately after it comes on the next time.
7. If the average of these readings varies by more than 10 °F from the dial setting, recalibrate by the following procedure. **Recalibration should be attempted only by a competent service technician.**

Use the following procedure to recalibrate the oven:

1. Loosen the two set screws that secure the temperature-control knob to the temperature-control shaft.
2. Remove the knob from the shaft, being careful not to rotate the knob or shaft.
3. Replace the knob on the shaft so that the indicator mark on the knob points directly at the temperature that was measured at the center of the oven.
4. Re-check the oven calibration.



### SELECTING FAHRENHEIT OR CELSIUS DISPLAY (Cycle/Cook & Hold Models Only)

Ovens with Cycle/Cook & Hold controls can be configured to display temperatures using the Fahrenheit or the Celsius scales. To change the choice, change the position of the blue jumper “J3” on the rear of the control panel circuit board.

### CONVERSION FROM SINGLE-PHASE TO THREE-PHASE POWER (OR VICE VERSA)

Ovens are shipped wired for either single-phase or three-phase power according to the original factory order. If the oven installation requires changing the type of power used by the oven, follow the procedure below. The following drawing shows the locations of items referred to in the procedure.

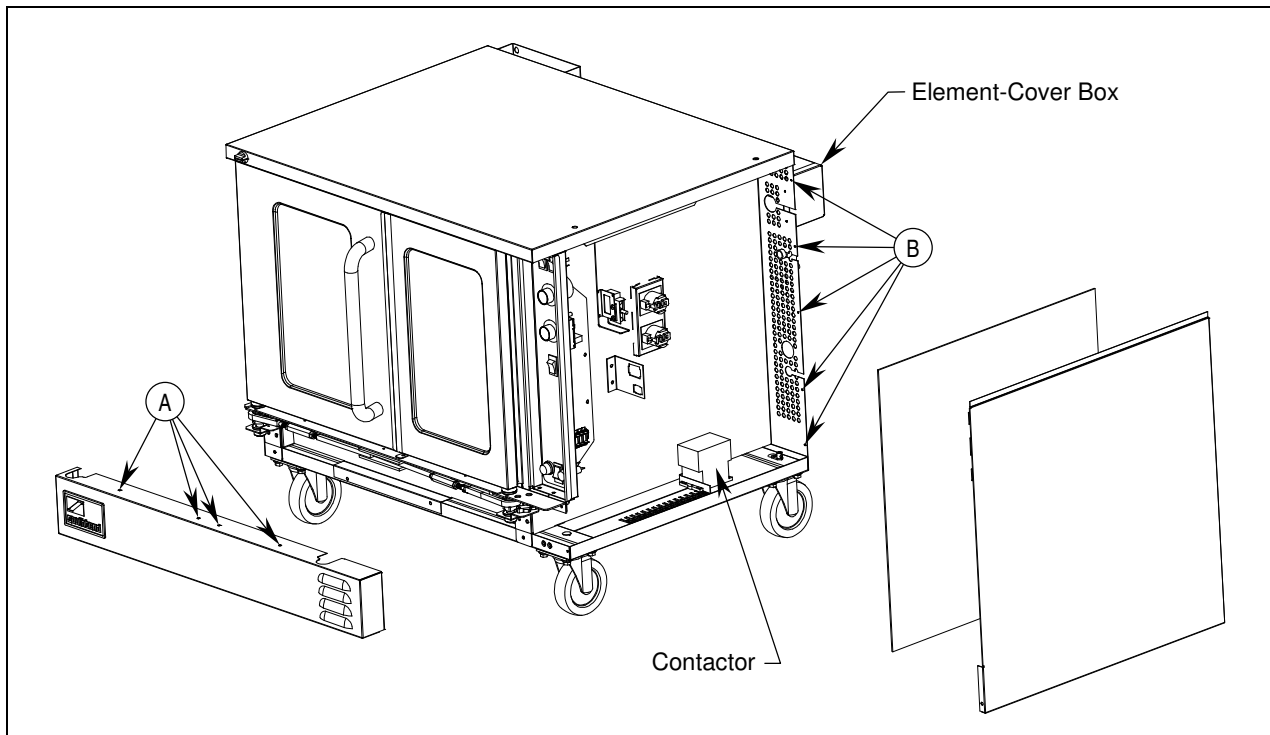

1. **If the oven is connected to a power supply, DISCONNECT OVEN FROM POWER SUPPLY.**
2. Remove the element-cover box from the back of the oven. (An oven built for three-phase power will have a small jumper wire attached with the element box cover to the back of the oven. Keep this wire.)
3. Locate and remove the four screws that secure the lower front panel (items “A” in the drawing above). Lift up the panel and pull it forward to remove it, then set it aside.
4. Locate and remove the now-accessible screw that secures the lower front corner of the side panel.
5. Locate and remove the five screws that secure the back edge of the side panel to the oven (items “B” in the drawing above). Remove the side panel and insulation and set them aside.
6. Locate the wires running from the supply-power terminal block to the contactor. If converting from three-phase to single-phase power, remove the wire T2 (as shown in the following drawing) and go on to the next step. If converting from single-phase to three-phase power, locate the wires running from the contactor to the elements. Attached to those wires (with a wire tie) will be two wires that are not being used. Use the shorter of the two extra wires to make the additional connection (T2) shown in the following drawing. Keep the longer wire to use in the next step. (Note: If you are changing the phase-wiring of a 415V oven, refer to the corresponding wiring diagram for conversion. See page 38.)

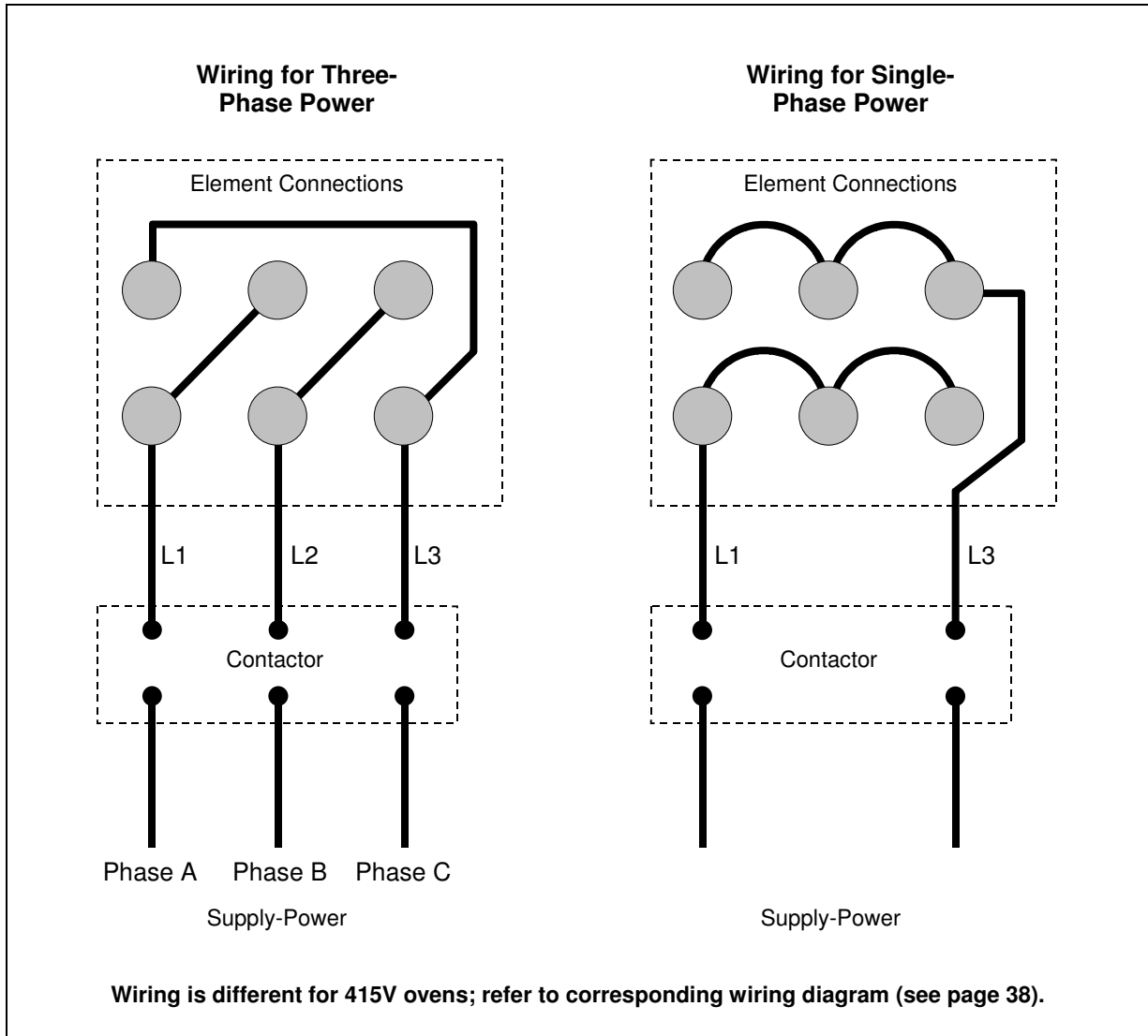

7. Locate the wires running from the contactor to the elements. If converting from three-phase to single-phase power, remove the wire L2 (as shown in the above drawing) and go on to the next step. If converting from single-phase to three-phase power, use the longer of the two extra wires found in the previous step to make the additional connection (L2) shown in the above drawing. (Again, if you are changing the phase-wiring of a 415V oven, refer to the corresponding wiring diagram for conversion. See page 38.)
8. Rewire the connections to the elements (located on the back of the oven) according to the diagram at the top of this page. If converting from three-phase to single-phase, use the wire that you saved in Step 2 to make one of the connections. (Once more, if you are changing the phase-wiring of a 415V oven, refer to the corresponding wiring diagram for conversion. See page 38.)
9. **Carefully compare the new wiring connections at the elements, contactor, and supply-power terminal block to the wiring diagram for the oven.** (See page 37 for the location of the wiring diagram on the oven, or page 38 for wiring diagrams printed in this manual). **Verify that all connections are tight.**
10. Reattach the element-cover box, right-side panel, and lower-front panel.
11. Connect the oven to the power supply according to the procedure on page 15. **Note that the supply-power connections depend on whether the supply power is three-phase or single phase, and so will be different than they were prior to the conversion.**

ADJUSTMENTS

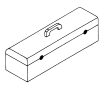

# TROUBLESHOOTING

## **WARNING**

ADJUSTMENTS AND SERVICE WORK MAY BE PERFORMED ONLY BY A QUALIFIED TECHNICIAN WHO IS EXPERIENCED IN, AND KNOWLEDGEABLE WITH, THE OPERATION OF COMMERCIAL COOKING EQUIPMENT. HOWEVER, TO ASSURE YOUR CONFIDENCE, CONTACT YOUR AUTHORIZED SERVICE AGENCY FOR RELIABLE SERVICE, DEPENDABLE ADVICE OR OTHER ASSISTANCE, AND FOR GENUINE FACTORY PARTS.

## **NOTICE**

Warranty will be void and the manufacturer is relieved of all liability if service work is performed by other than a qualified technician, or if other than genuine Southbend replacement parts are installed.

When any difficulty arises it is always a good idea to check that the oven has been connected to the type of voltage for which it was manufactured. The serial plate is located on the inside of the lower front panel. It will list the type of voltage for which the unit was manufactured. In addition, a wiring diagram is attached to the side of the fold down control panel, as well as reproduced in this manual (see page 38).

## PERFORMANCE STANDARD

The typical time for the oven to heat from 75°F to 350°F is 7 to 8 minutes. The heating elements should come on when the actual oven temperature drops to 10°F below the temperature setting.

## TROUBLESHOOTING GUIDE

The left column of the following table lists symptoms that indicate a problem, while the center and right columns list the possible causes and appropriate corrective action. Note that the recommendations of this table assume that the wiring connections are good. When checking a component, always check the wiring attached to the component as well.

Symptom	Possible Cause	Check or Replace
Oven will not hold correct temperature.	Temperature probe not working.	Resistance across temperature probe leads at room temperature (70°F) should be approximately 1096 ohms.
	Temperature control not calling for heat.	When heat is required, there should be continuity between terminals 6 and 7 on temperature control.
	Inadequate or improper ventilation.	Check ventilation hood. Verify draw and make up air adjustment.
	Out of calibration.	Calibrate according to procedure described on page 33.
Blower motor will not come on.	No incoming electric power.	Check incoming power.
	Loose wire connections.	Check wire connections.
	Bad contactors.	Contactors pull in and supply power to motor. Verify contactors pulling in.
	Motor bad.	If power is being supplied but motor will not turn, replace motor.
	Shut down switch.	All power except for motor supply come through shut down switch. Check for continuity.

TROUBLESHOOTING

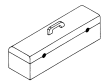

### INTERPRETING DISPLAYED ERROR CODES

Programmable and Rack Timer models are able to detect some problems that might occur. If the control panel display is showing a letter “F” followed by a number, consult the following table to determine the problem and appropriate corrective action.

Symptom	Possible Cause	Check or Replace
Display shows F1	Bad temperature controller.	Replace temperature controller.
Display shows F2	Oven interior maximum temperature exceeded.	Check whether element contactor is stuck shut. If not, replace temperature controller.
Display shows F3	Open temperature probe.	Check connection. If connection is OK, replace probe.
Display shows F4	Shorted temperature probe.	Check probe wires. If wires are not shorted, replace probe.
Display shows F5	Bad temperature controller.	Replace temperature controller.
Display shows F6	Bad temperature controller.	Replace temperature controller.
Display shows F7	Total cook time in a program exceeds 24 hours (programmable models only).	Change program so that total cook time does not exceed 24 hours.
Display shows F8	Bad temperature controller.	Replace temperature controller.

### CONTROL PANEL ACCESS AND SHUT-OFF SWITCH

To access the control panel components, remove the screw at the top of the control panel and pull the top of the control panel out and down (see drawing below). A wiring diagram for the oven is located on the side of the control panel assembly. **When the control panel is folded down, all power to the control panel is cut off by a shut down switch that is located directly behind and below the control panel.** To re-energize the controls for troubleshooting, pull the white plunger on the shut down switch up.

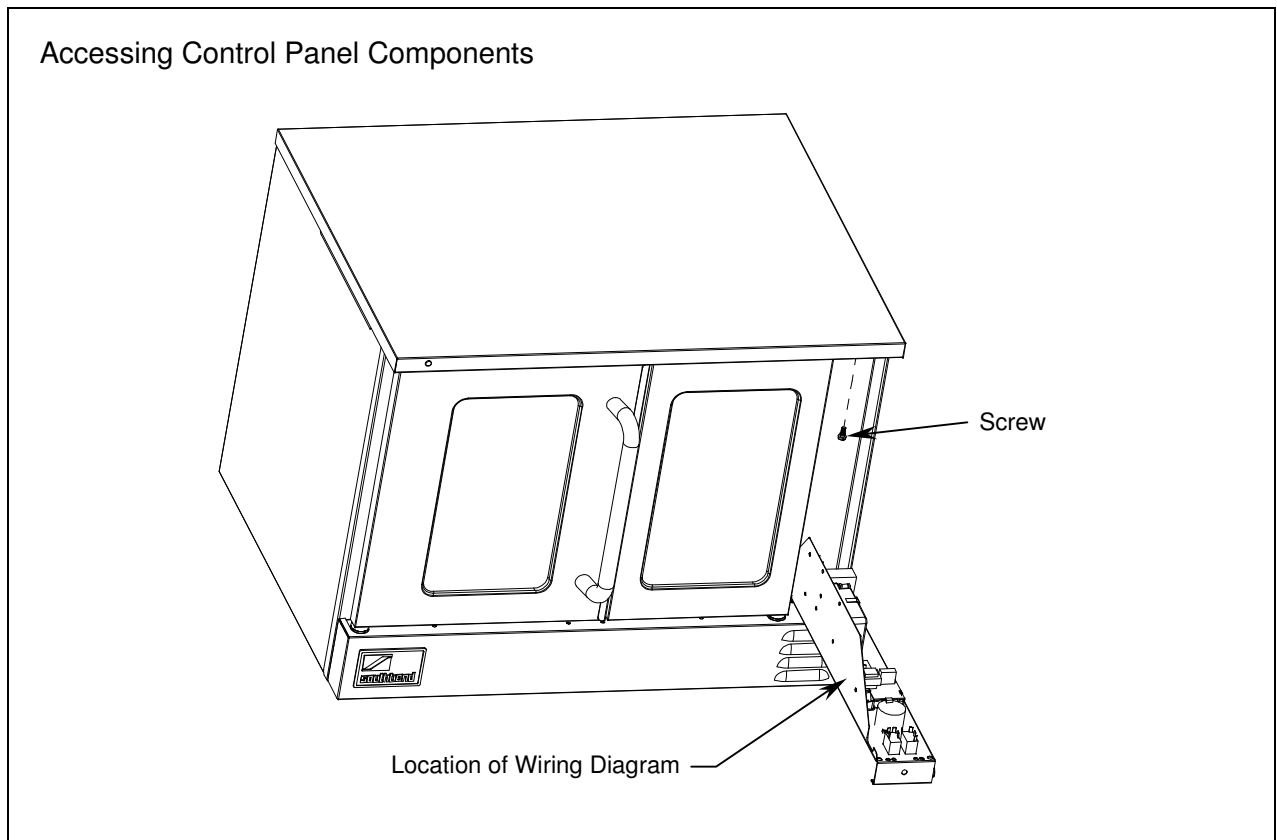

TROUBLESHOOTING

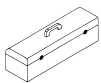

## BLOWER WHEEL REPLACEMENT

To replace the blower wheel, do the following:

1. Remove racks and rack guides.
2. Remove side air baffle in front of blower wheel.
3. Loosen the two square heads on blower wheel hub.
4. Pull blower wheel from motor shaft. If blower wheel is difficult to pull off, use puller disk (available from Southbend as part number 1179100).

## WIRING DIAGRAMS

A wiring diagram is located on the side of the control panel assembly (as shown on page 37). Wiring diagrams also appear on the following pages of this manual. Which wiring diagram is appropriate depends on the voltage and type of controls.

<b>Index of Wiring Diagrams</b>	
Page Number	Voltage and Type of Controls
39	208-240 Volt Models with Standard Controls
40	480 Volt Models with Standard Controls
41	415/240 Volt Models with Standard Controls
42	380/220 Volt Models with Standard Controls
43	208-240 Volt Models with Cycle/Cook & Hold Controls
44	480 Volt Models with Cycle/Cook & Hold Controls
45	415/240 Volt Models with Cycle/Cook & Hold Controls
46	380/220 Volt Models with Cycle/Cook & Hold Controls
47	208-240 Volt Models with Programmable or Rack Timer Controls
48	480 Volt Models with Programmable or Rack Timer Controls
49	415/240 Volt Models with Programmable or Rack Timer Controls
50	380/220 Volt Models with Programmable or Rack Timer Controls

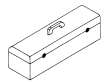

Wiring Diagram for 208-240 Volt Models with Standard Controls

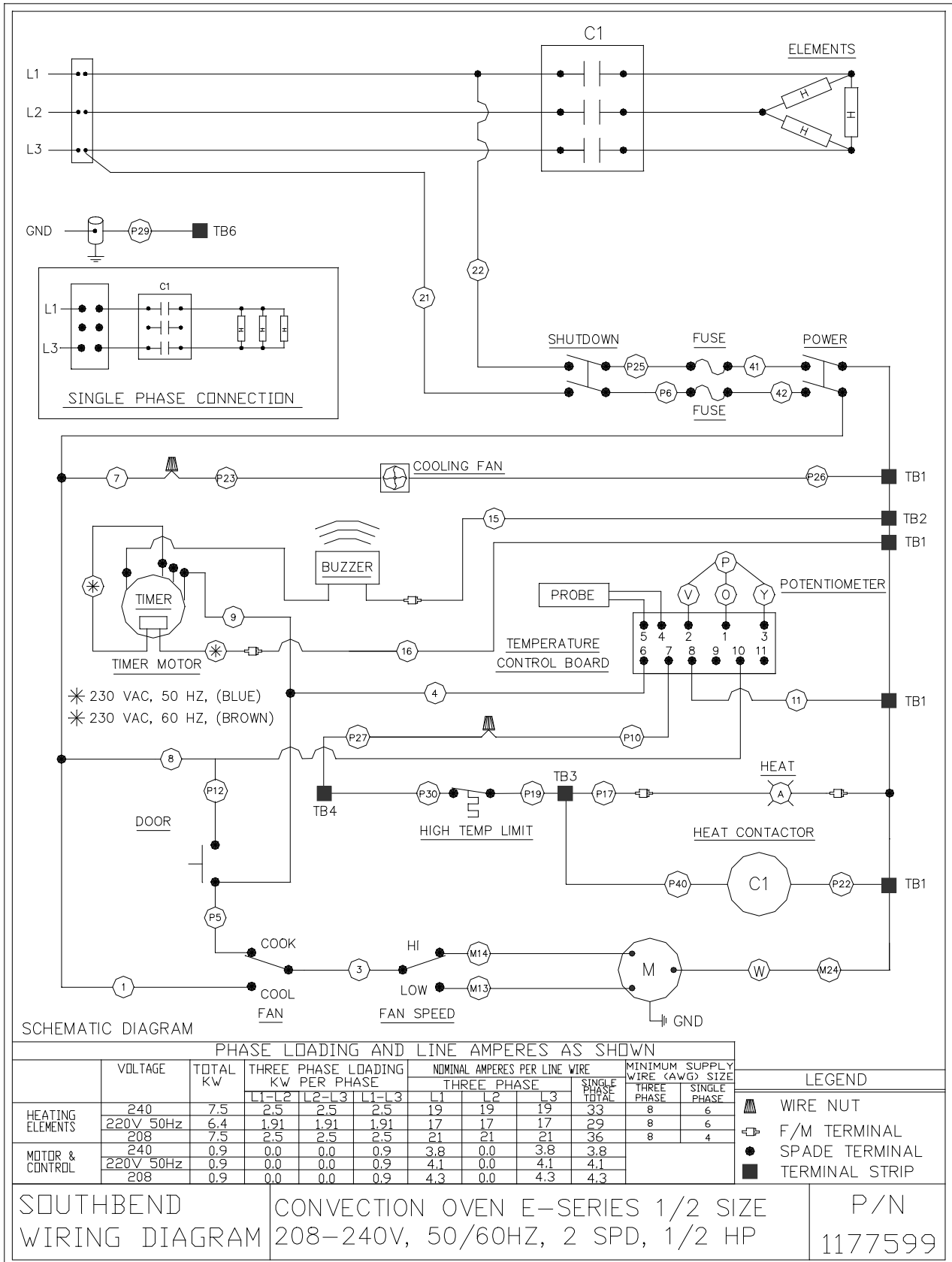

TROUBLESHOOTING

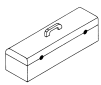

## Wiring Diagram for 480 Volt Models with Standard Controls

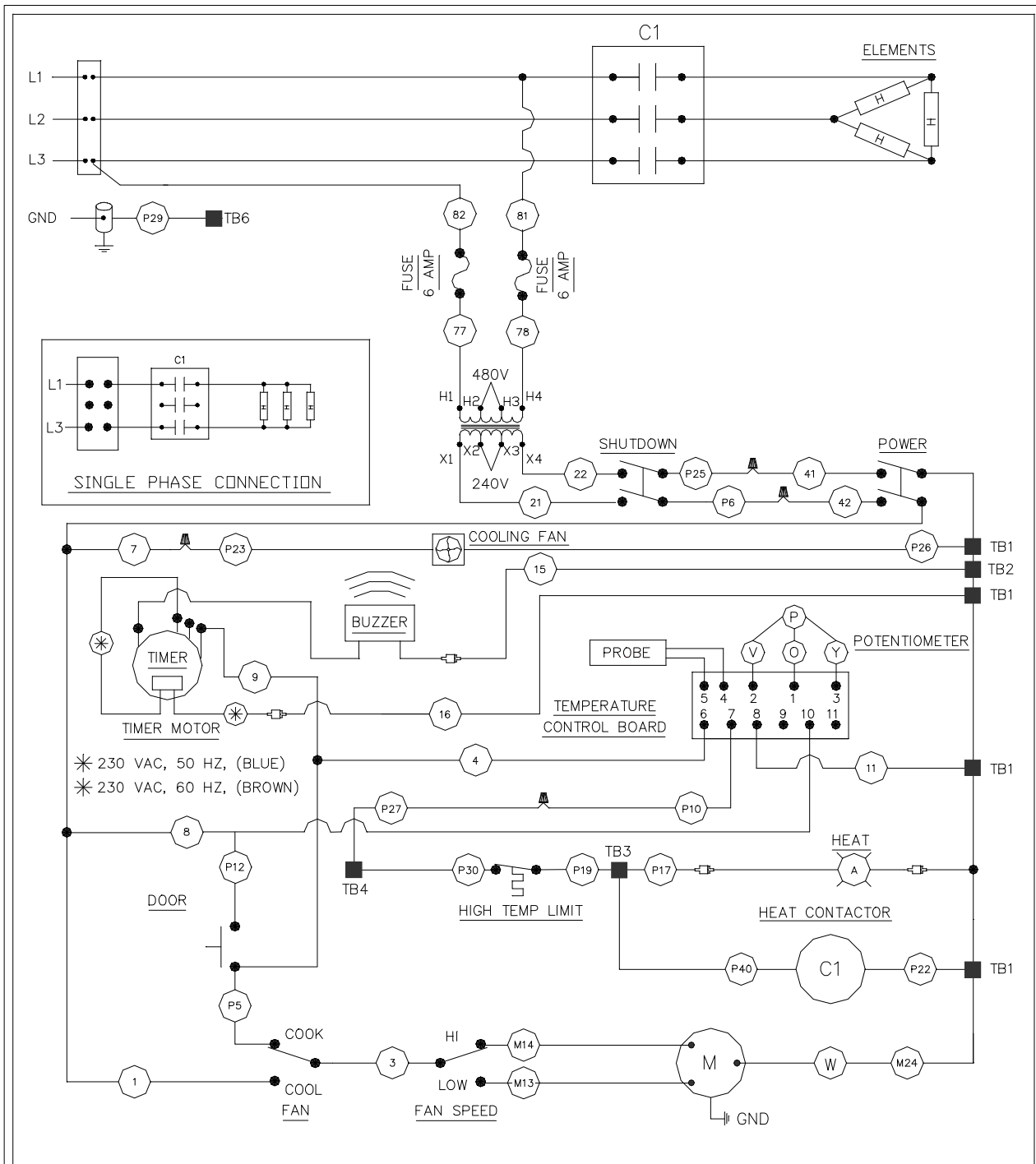

SCHEMATIC DIAGRAM

PHASE LOADING AND LINE AMPERES AS SHOWN

	VOLTAGE	TOTAL KW	THREE PHASE LOADING KW PER PHASE			NOMINAL AMPERES PER LINE WIRE				MINIMUM SUPPLY WIRE (AWG) SIZE		
			L1-L2	L2-L3	L1-L3	THREE PHASE			SINGLE PHASE TOTAL	THREE PHASE	SINGLE PHASE	
						L1	L2	L3				
HEATING ELEMENTS	480	7.5	2.5	2.5	2.5	11	11	11	18.0	12	10	
MOTOR & CONTROL	480	0.9	0.0	0.0	0.9	2.2	0.0	2.2	2.2			

LEGEND

- WIRE NUT
- F/M TERMINAL
- SPADE TERMINAL
- TERMINAL STRIP

SOUTHBEND  
WIRING DIAGRAM

CONVECTION OVEN E-SERIES 1/2 SIZE  
480V, 50/60HZ, 2 SPD, 1/3 HP

P/N  
1177606

TROUBLESHOOTING



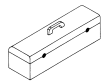

Wiring Diagram for 415/240 Volt Models with Standard Controls

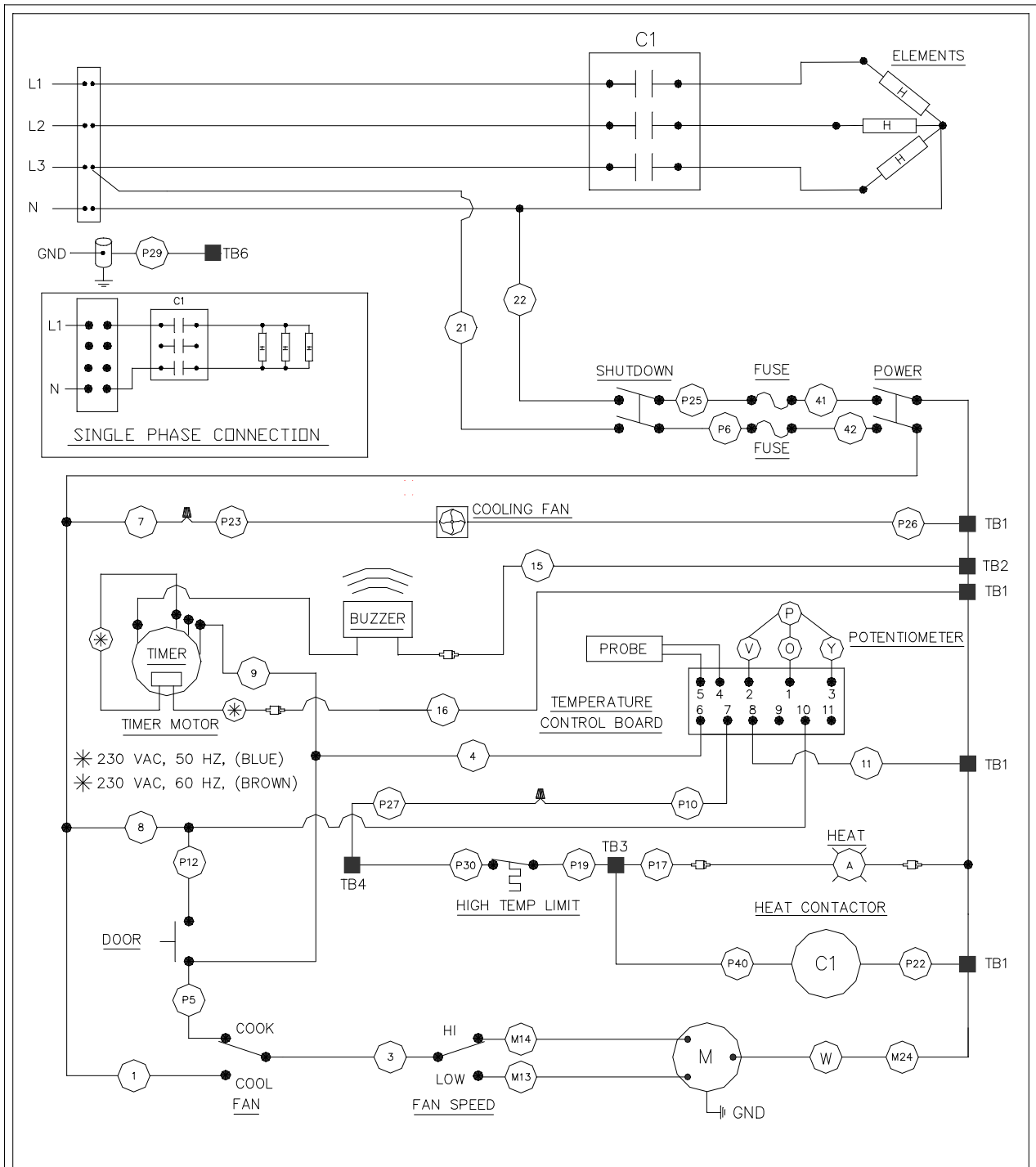

SCHEMATIC DIAGRAM

LEGEND

PHASE LOADING AND LINE AMPERES AS SHOWN

	VOLTAGE	TOTAL KW	THREE PHASE LOADING KW PER PHASE			NOMINAL AMPERES PER LINE WIRE				MINIMUM SUPPLY WIRE (AWG) SIZE		
			L1-L2	L2-L3	L1-L3	THREE PHASE			SINGLE PHASE TOTAL	THREE PHASE	SINGLE PHASE	
			L1	L2	L3	L1	L2	L3				
HEATING ELEMENTS	415	7.5	2.5	2.5	2.5	11	11	11	34.0	12	6	
MOTOR & CONTROL	415	0.9	0.0	0.0	0.9	0.0	0.0	3.8	3.8			

- WIRE NUT
- F/M TERMINAL
- SPADE TERMINAL
- TERMINAL STRIP

SOUTHBEND  
WIRING DIAGRAM

CONVECTION OVEN E-SERIES 1/2 SIZE  
415/240V, 3Ø 4W, 50/60HZ, 2 SPD, 1/3 HP

P/N  
1177607

TROUBLESHOOTING

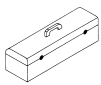

## Wiring Diagram for 380/220 Volt Models with Standard Controls

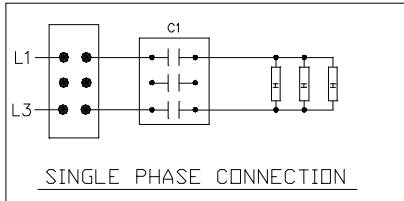
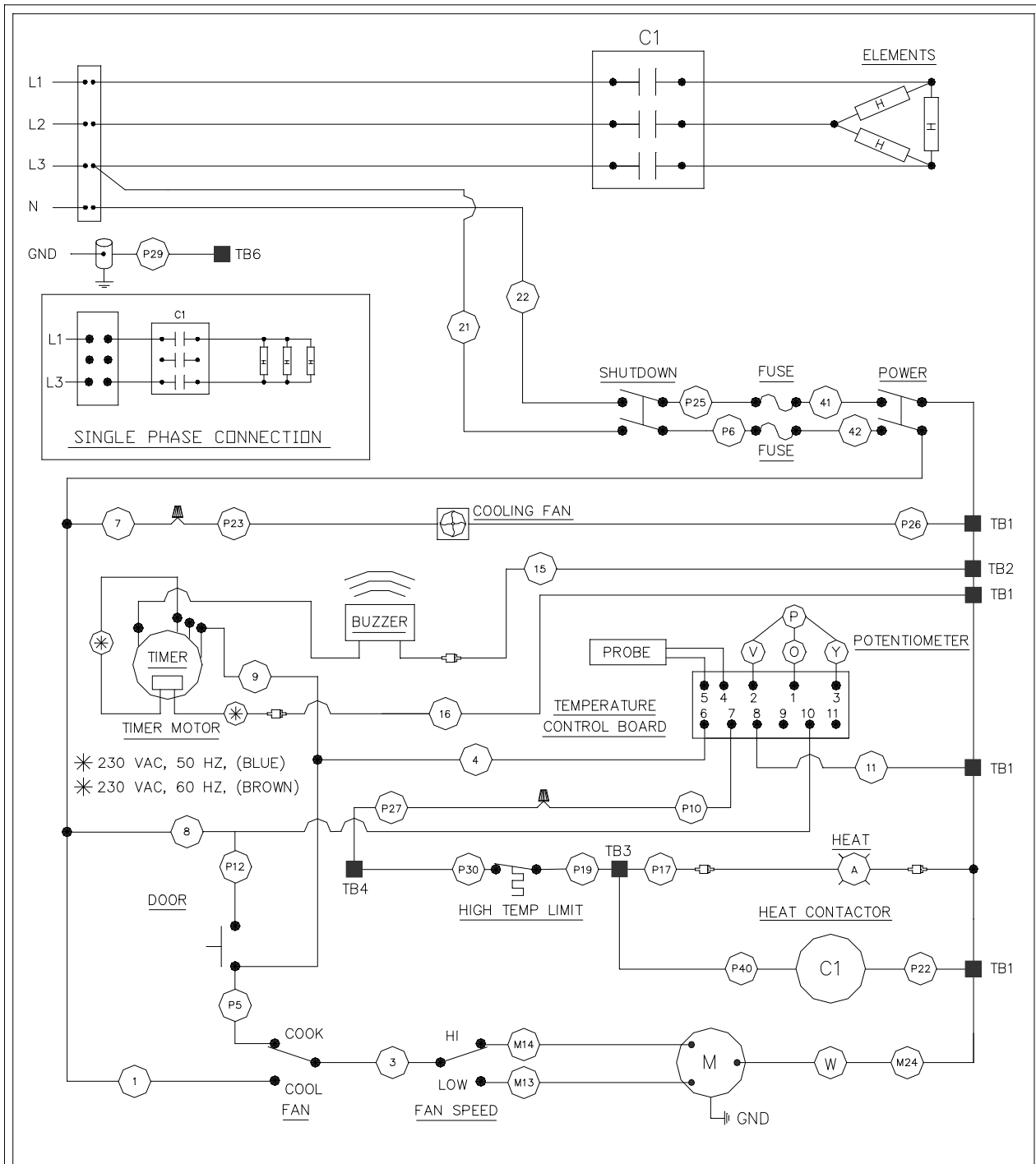

SCHEMATIC DIAGRAM

PHASE LOADING AND LINE AMPERES AS SHOWN

	VOLTAGE	TOTAL KW	THREE PHASE LOADING KW PER PHASE			NOMINAL AMPERES PER LINE WIRE				MINIMUM SUPPLY WIRE (AWG) SIZE		
			L1-L2	L2-L3	L1-L3	THREE PHASE			SINGLE PHASE TOTAL	THREE PHASE	SINGLE PHASE	
						L1	L2	L3				
HEATING ELEMENTS	380	7.5	2.5	2.5	2.5	12	12	12	20.0	12	8	
MOTOR & CONTROL	380	0.9	0.0	0.9	0.0	0.0	0.0	4.1	4.1			

LEGEND

- WIRE NUT
- F/M TERMINAL
- SPADE TERMINAL
- TERMINAL STRIP

SOUTHBEND

CONVECTION OVEN E-SERIES 1/2 SIZE

P/N

WIRING DIAGRAM

380/220V, 3φ 4W, 50/60HZ, 2 SPD, 1/3 HP

1177608

TROUBLESHOOTING

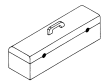

Wiring Diagram for 208-240 Volt Models with Cycle/Cook & Hold Controls

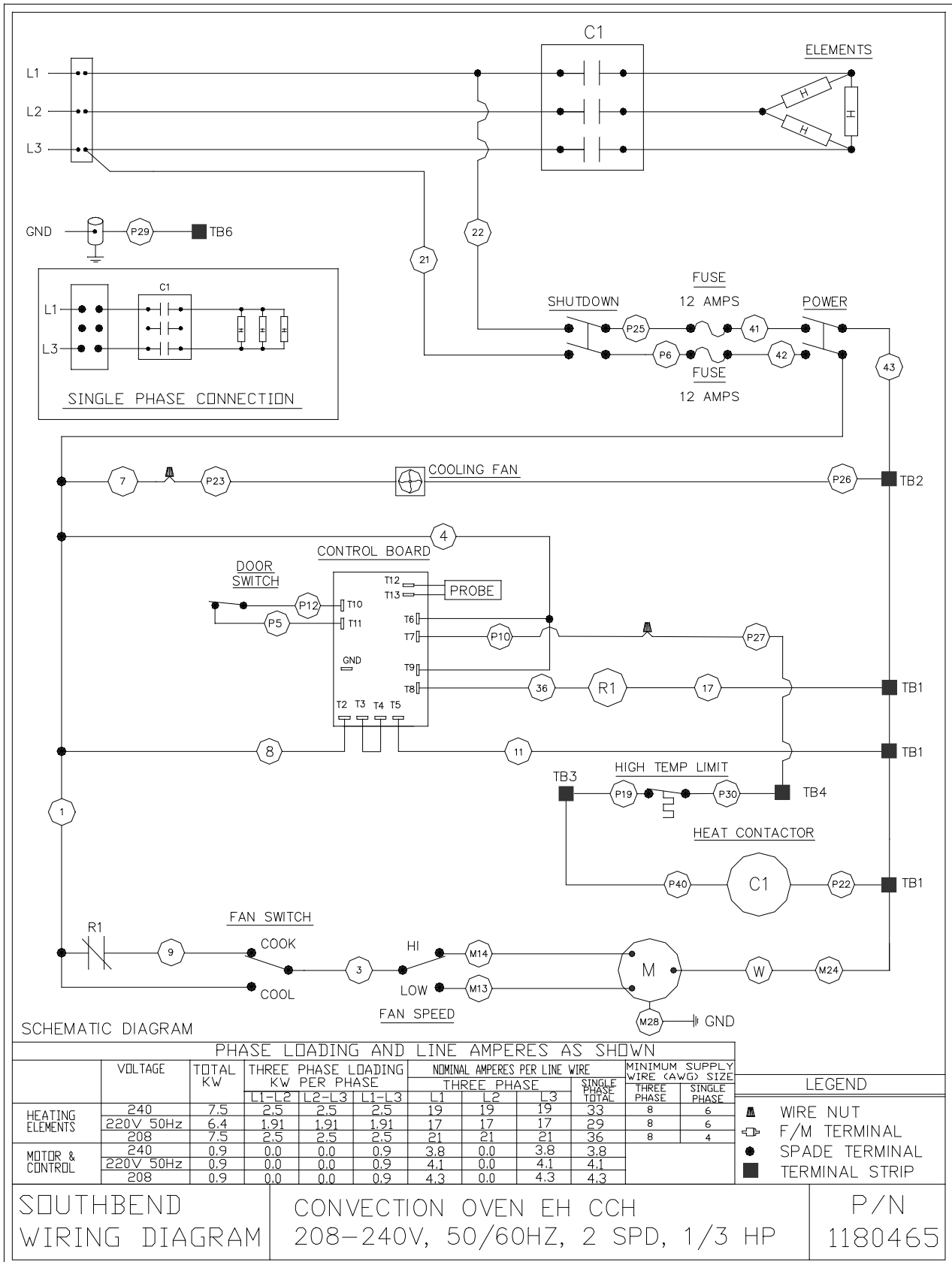

TROUBLESHOOTING

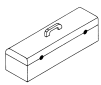

Wiring Diagram for 480 Volt Models with Cycle/Cook & Hold Controls

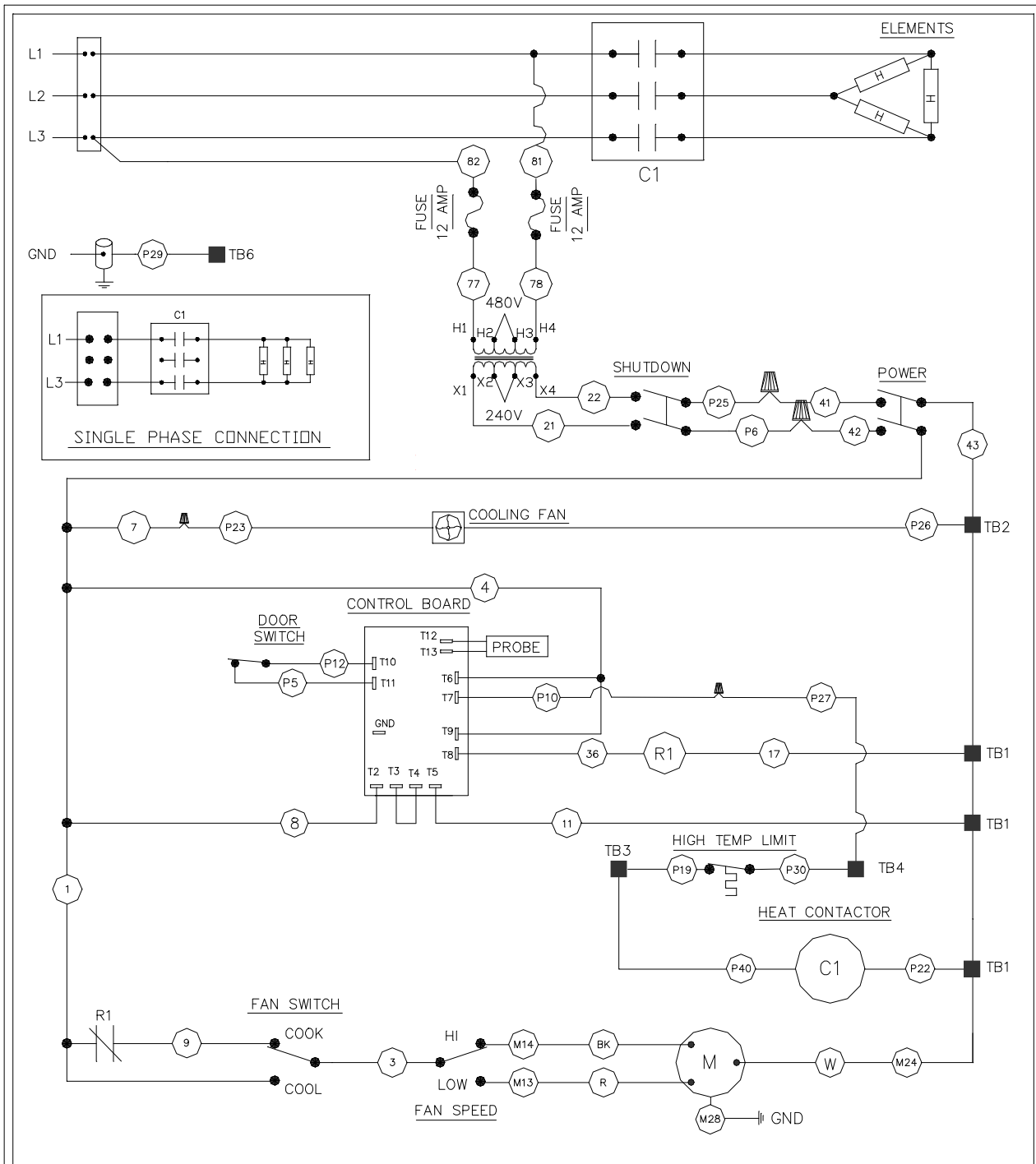

SCHEMATIC DIAGRAM

PHASE LOADING AND LINE AMPERES AS SHOWN

	VOLTAGE	TOTAL KW	THREE PHASE LOADING KW PER PHASE			NOMINAL AMPERES PER LINE WIRE				MINIMUM SUPPLY WIRE (AWG) SIZE		
			L1-L2	L2-L3	L1-L3	L1	L2	L3	SINGLE PHASE TOTAL	THREE PHASE	SINGLE PHASE	
HEATING ELEMENTS	480	7.5	2.5	2.5	2.5	11	11	11	18.0	12	10	
MOTOR & CONTROL	480	0.9	0.0	0.0	0.9	2.2	0.0	2.2	2.2			

LEGEND	
	WIRE NUT
	F/M TERMINAL
	SPADE TERMINAL
	TERMINAL STRIP

SOUTHBEND  
WIRING DIAGRAM

CONVECTION OVEN EH CCH  
480V, 50/60HZ, 2 SPD, 1/3 HP

P/N  
1180462

TROUBLESHOOTING

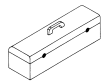

Wiring Diagram for 415/240 Volt Models with Cycle/Cook & Hold Controls

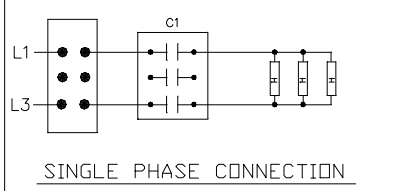
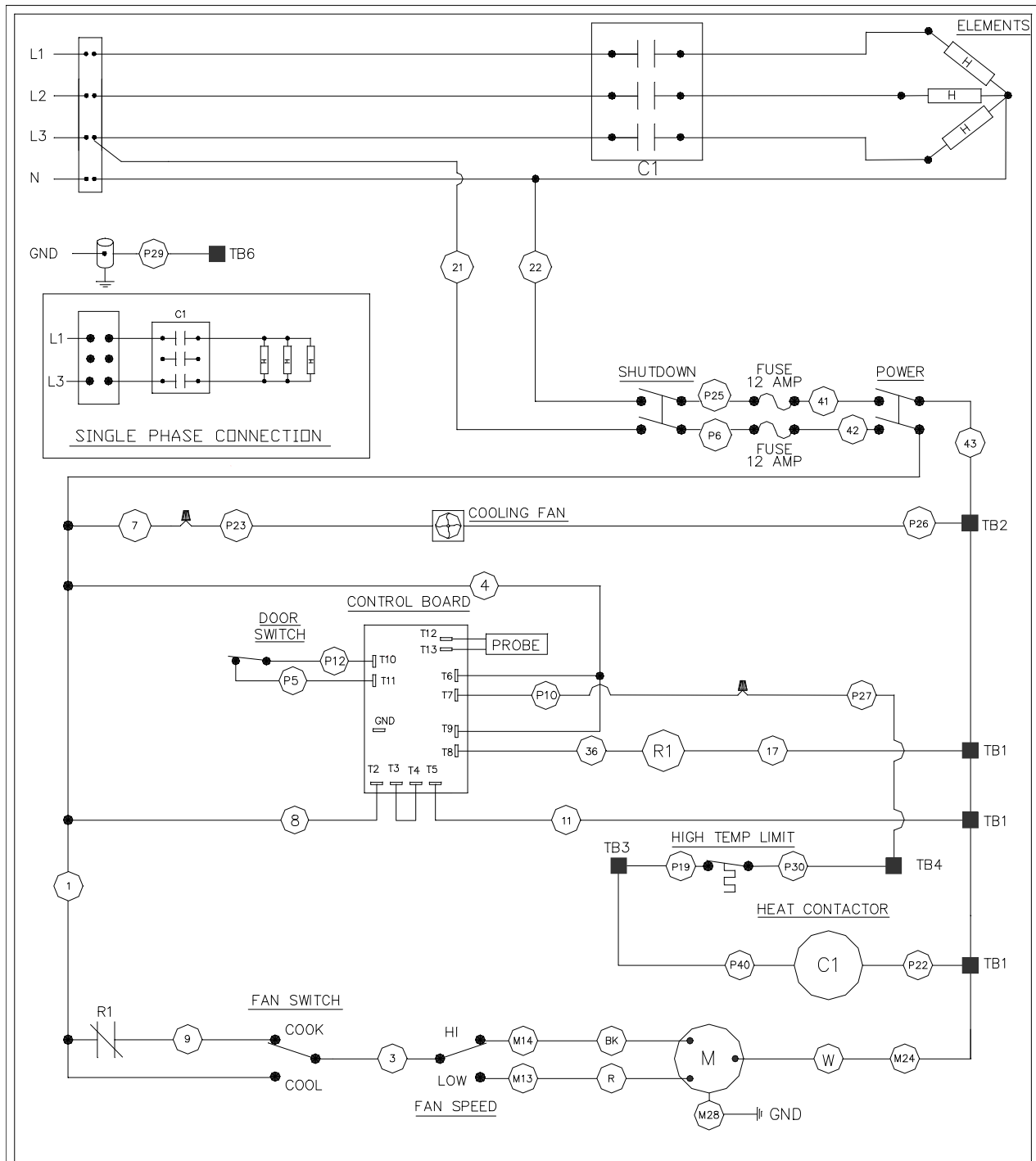

SCHEMATIC DIAGRAM

LEGEND

	VOLTAGE	TOTAL KW	THREE PHASE LOADING KW PER PHASE			NOMINAL AMPERES PER LINE WIRE				MINIMUM SUPPLY WIRE (AWG) SIZE	
			L1-L2	L2-L3	L1-L3	THREE PHASE			SINGLE PHASE TOTAL	THREE PHASE	SINGLE PHASE
			L1	L2	L3	L1	L2	L3			
HEATING ELEMENTS	415	7.5	2.5	2.5	2.5	11	11	11	34.0	12	6
MOTOR & CONTROL	415	0.9	0.0	0.0	0.9	0.0	0.0	3.8	3.8		

- ▲ WIRE NUT
- ⊕ F/M TERMINAL
- SPADE TERMINAL
- TERMINAL STRIP

SOUTHBEND  
WIRING DIAGRAM

CONVECTION OVEN EH CCH  
415/240V, 50/60HZ, 2 SPD, 1/3 HP

P/N  
1180463

TROUBLESHOOTING

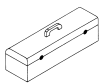

## Wiring Diagram for 380/220 Volt Models with Cycle/Cook & Hold Controls

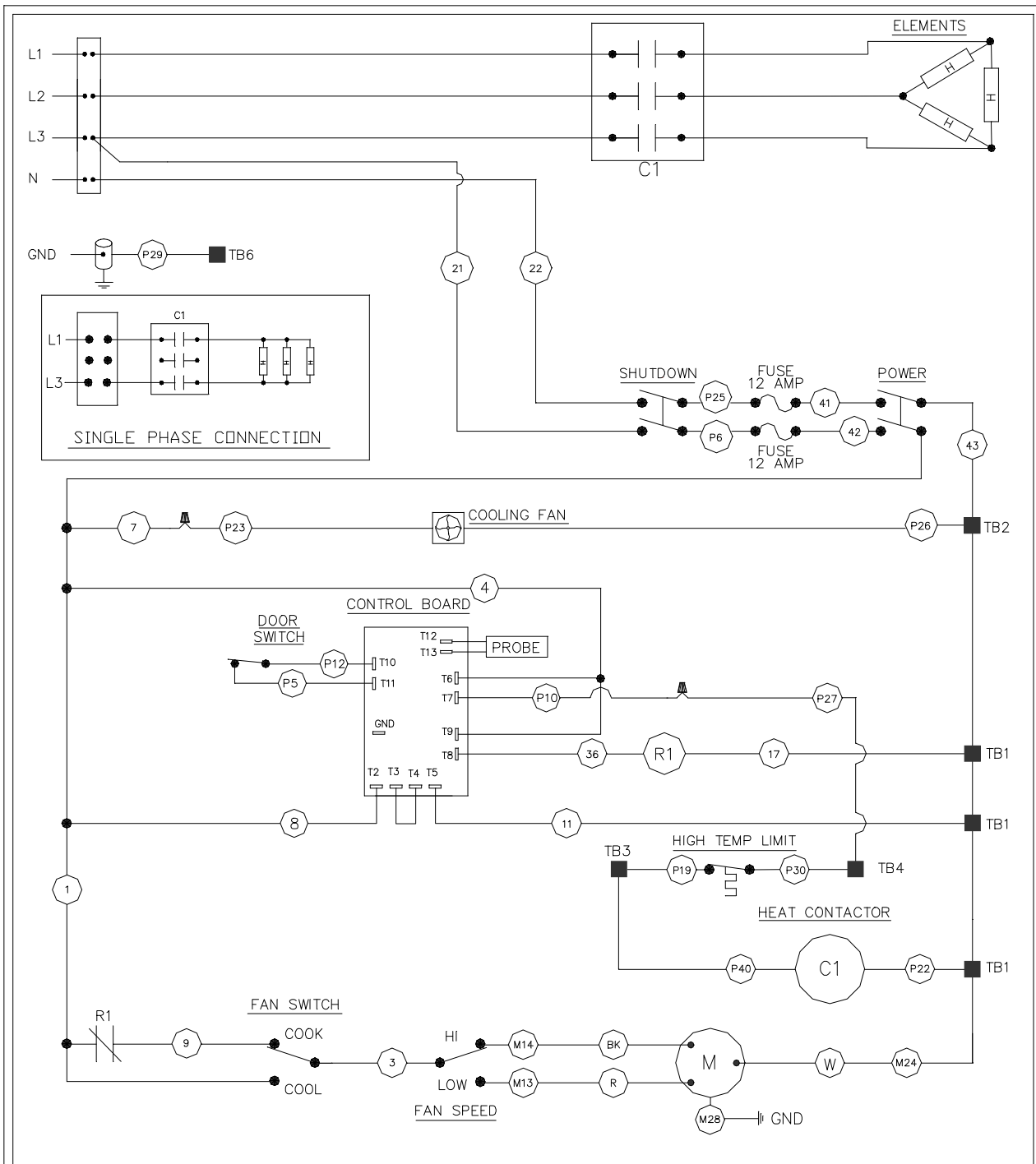

SCHEMATIC DIAGRAM

PHASE LOADING AND LINE AMPERES AS SHOWN

	VOLTAGE	TOTAL KW	THREE PHASE LOADING KW PER PHASE			NOMINAL AMPERES PER LINE WIRE				MINIMUM SUPPLY WIRE (AWG) SIZE	
			L1-L2	L2-L3	L1-L3	THREE PHASE			SINGLE PHASE TOTAL	THREE PHASE	SINGLE PHASE
						L1	L2	L3			
HEATING ELEMENTS	380	7.5	2.5	2.5	2.5	12	12	12	20.0	12	8
MOTOR & CONTROL	380	0.9	0.0	0.0	0.9	0.0	0.0	4.1	4.1		

LEGEND	
	WIRE NUT
	F/M TERMINAL
	SPADE TERMINAL
	TERMINAL STRIP

SOUTHBEND  
WIRING DIAGRAM

CONVECTION OVEN EH CCH  
380/220V, 50/60HZ, 2 SPD, 1/3 HP

P/N  
1180464

TROUBLESHOOTING

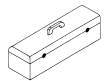

Wiring Diagram for 208-240 Volt Models with Programmable or Rack Timer Controls

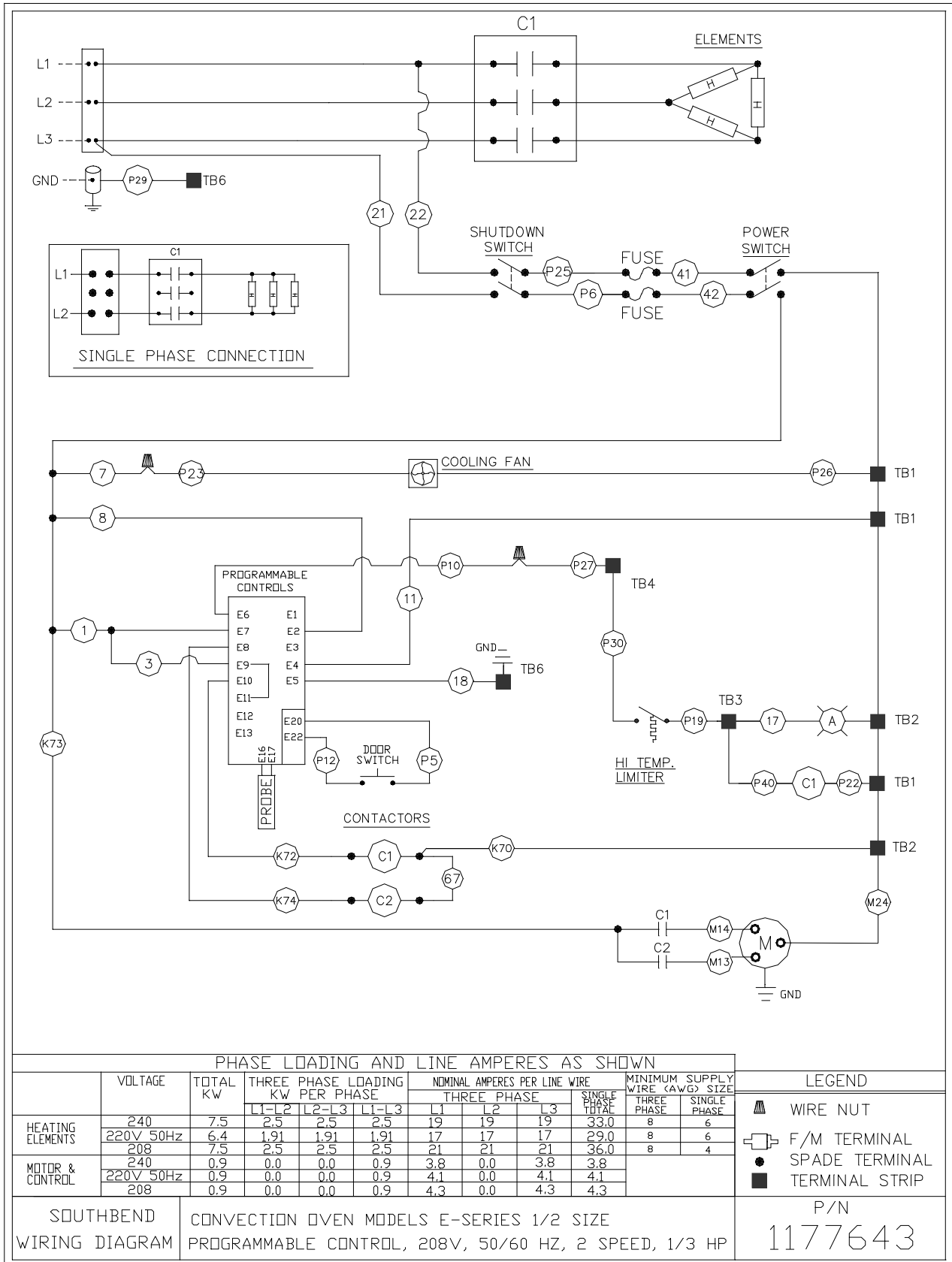

TROUBLESHOOTING

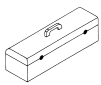

## Wiring Diagram for 480 Volt Models with Programmable or Rack Timer Controls

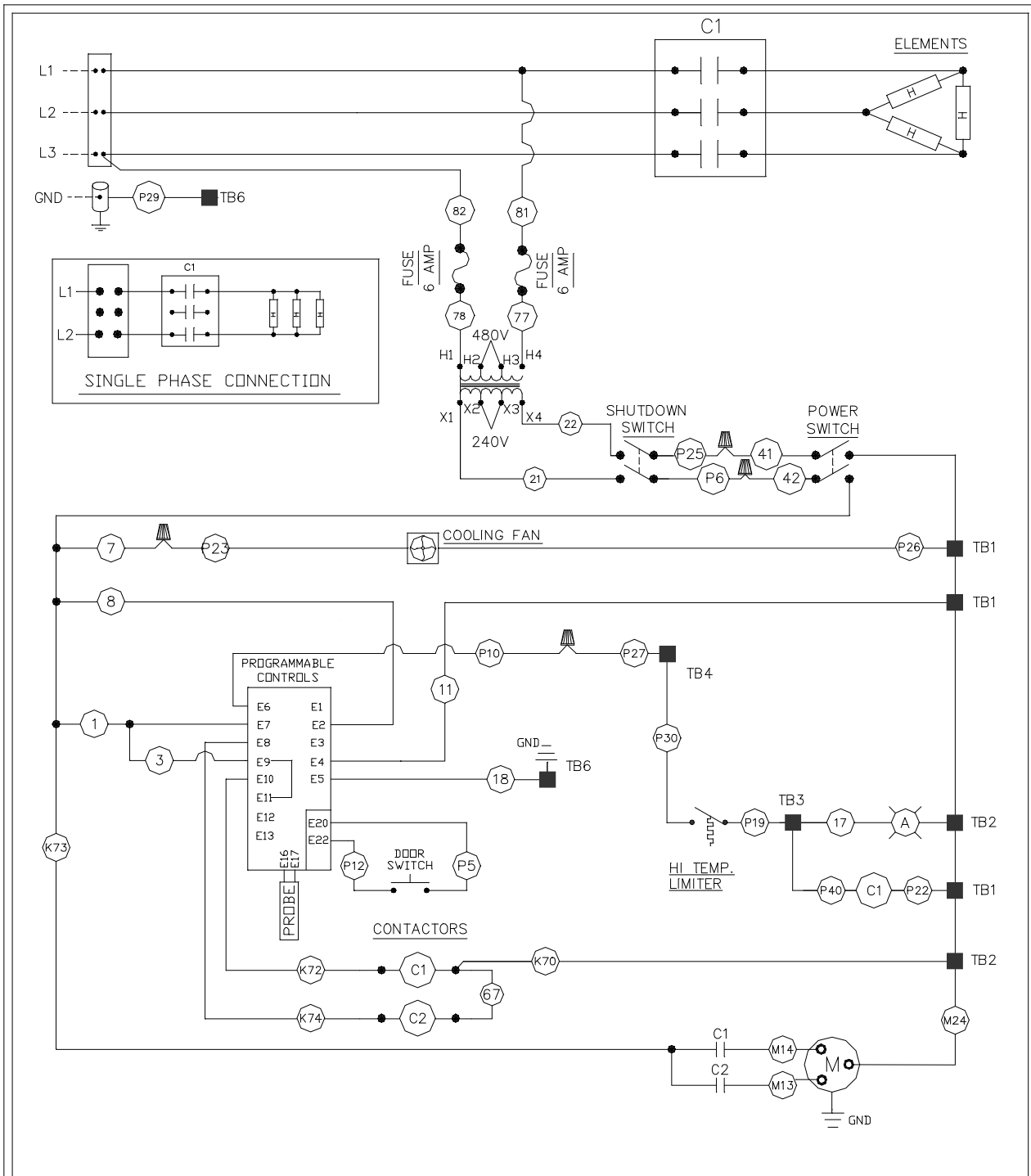

SCHEMATIC DIAGRAM

PHASE LOADING AND LINE AMPERES AS SHOWN

	VOLTAGE	TOTAL KW	THREE PHASE LOADING KW PER PHASE			NOMINAL AMPERES PER LINE WIRE				MINIMUM SUPPLY WIRE (AWG) SIZE	
			L1-L2	L2-L3	L1-L3	THREE PHASE			SINGLE PHASE TOTAL	THREE PHASE	SINGLE PHASE
						L1	L2	L3			
HEATING ELEMENTS	480	7.5	2.5	2.5	2.5	11	11	11	18.0	12	10
MOTOR & CONTROL	480	0.9	0.0	0.0	0.9	2.2	0.0	2.2	2.2		

LEGEND	
	WIRE NUT
	F/M TERMINAL
	SPADE TERMINAL
	TERMINAL STRIP

SOUTHBEND CONVECTION OVEN MODELS E-SERIES 1/2 SIZE  
 WIRING DIAGRAM PROGRAMMABLE CONTROL, 480V, 50/60 HZ, 2 SPEED, 1/3 HP

P/N  
 1177646

TROUBLESHOOTING

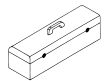

Wiring Diagram for 415/240 Volt Models with Programmable or Rack Timer Controls

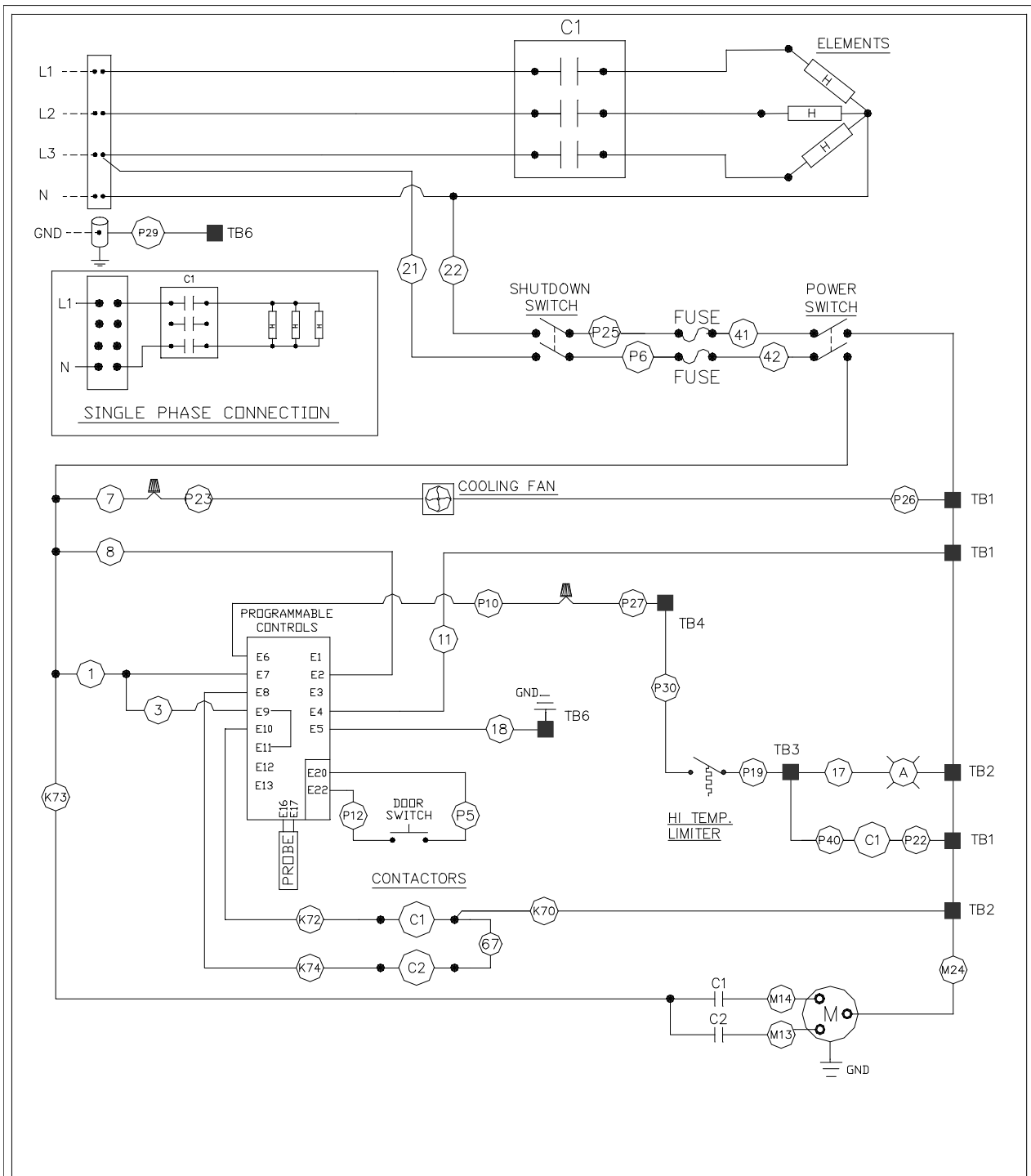

SCHEMATIC DIAGRAM

LEGEND

PHASE LOADING AND LINE AMPERES AS SHOWN

	VOLTAGE	TOTAL KW	THREE PHASE LOADING KW PER PHASE			NOMINAL AMPERES PER LINE WIRE				MINIMUM SUPPLY WIRE (AWG) SIZE		
			L1-L2	L2-L3	L1-L3	THREE PHASE			SINGLE PHASE TOTAL	THREE PHASE	SINGLE PHASE	
HEATING ELEMENTS	415	7.5	2.5	2.5	2.5	11	11	11	34.0	12	6	
MOTOR & CONTROL	415	0.9	0.0		0.9	0.0	0.0	3.8	3.8			

- WIRE NUT
- F/M TERMINAL
- SPADE TERMINAL
- TERMINAL STRIP

SOUTHBEND CONVECTION OVEN MODELS E-SERIES 1/2 SIZE  
 WIRING DIAGRAM PROGRAMMABLE CONTROL, 415/240V, 3Ø 4W, 50/60 HZ,  
 2 SPEED, 1/3 HP.

P/N  
 1177645

TROUBLESHOOTING

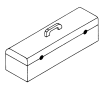

Wiring Diagram for 380/220 Volt Models with Programmable or Rack Timer Controls

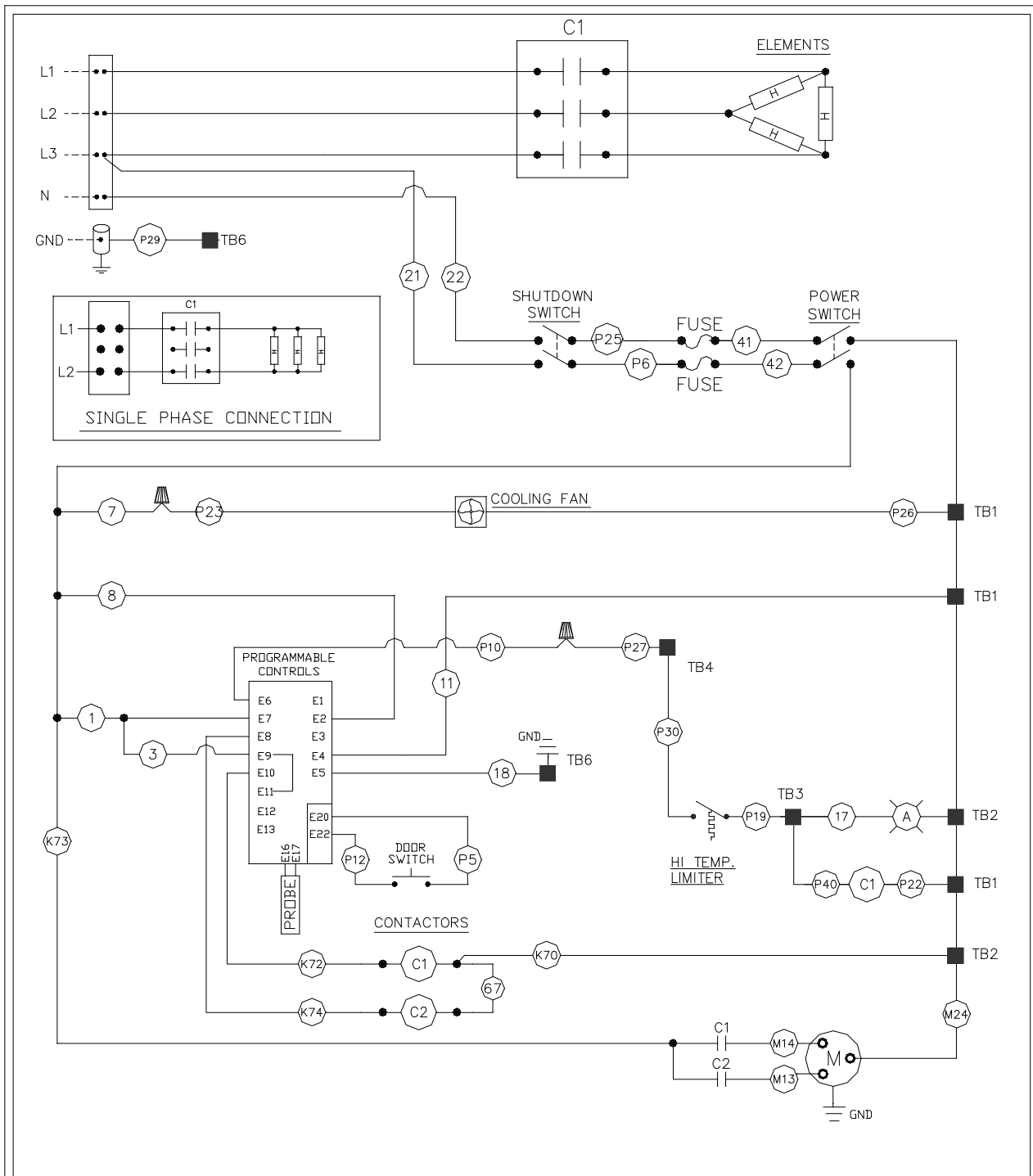

SCHEMATIC DIAGRAM

PHASE LOADING AND LINE AMPERES AS SHOWN

	VOLTAGE	TOTAL KW	THREE PHASE LOADING KW PER PHASE			NOMINAL AMPERES PER LINE WIRE				MINIMUM SUPPLY WIRE (AWG) SIZE	
			L1-L2	L2-L3	L1-L3	THREE PHASE			SINGLE PHASE TOTAL	THREE PHASE	SINGLE PHASE
						L1	L2	L3			
HEATING ELEMENTS	380	7.5	2.5	2.5	2.5	12	12	12	20.0	12	8
MOTOR & CONTROL	380	0.9	0.0	1.3-N	0.9	0.0	0.0	4.1	4.1		

LEGEND	
	WIRE NUT
	F/M TERMINAL
	SPADE TERMINAL
	TERMINAL STRIP

SOUTHBEND  
WIRING DIAGRAM

CONVECTION OVEN MODELS E-SERIES 1/2 SIZE  
PROGRAMMABLE CONTROL, 380/220V, 3Ø 4W, 50/60 HZ,  
2 SPEED, 1/3 HP.

P/N  
1177644

TROUBLESHOOTING

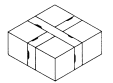

# PARTS

## NOTICE

INSTALLATION OF OTHER THAN GENUINE SOUTHBEND PARTS WILL VOID THE WARRANTY ON THIS EQUIPMENT.

The serial plate with voltage, model, and serial information is located inside the lower front panel of the oven.

Replacement parts may be ordered either through a Southbend Authorized Parts Distributor or a Southbend Authorized Service Agency.

When ordering parts, please supply the Model Number, Serial Number, Part Number, Description, Finish, and Electrical Characteristics as applicable.

For parts not listed, consult a Southbend Authorized Parts Distributor or Southbend Authorized Service Agency. Consult the Southbend Authorized Parts/Service Distributor list for the Authorized Parts supplier in your area.

<b>Index of Parts Diagrams</b>	
Page Number	Description
52	Vent Knob, Door Gaskets, and Front Louver Panel Parts
53	Door, Door Latch, and Shutdown Switch Parts
54	Control Panel Parts for Models with Standard Controls (SC Models)
56	Control Panel Parts for Cycle/Cook and Hold Models (CCH Models)
58	Control Panel Parts for Models with Programmable Controls (PC Models)
60	Control Panel Parts for Models with Rack Timer Controls (RT Models)
62	Oven Interior and Side-Compartment Parts
64	Leg Parts for Single-Deck Models
65	Storage Rack Parts
66	Double-Deck Oven Stacking Parts
67	Leg Parts for Double-Deck Ovens

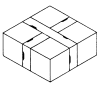

Vent Knob, Door Gaskets, and Front Louver Panel Parts

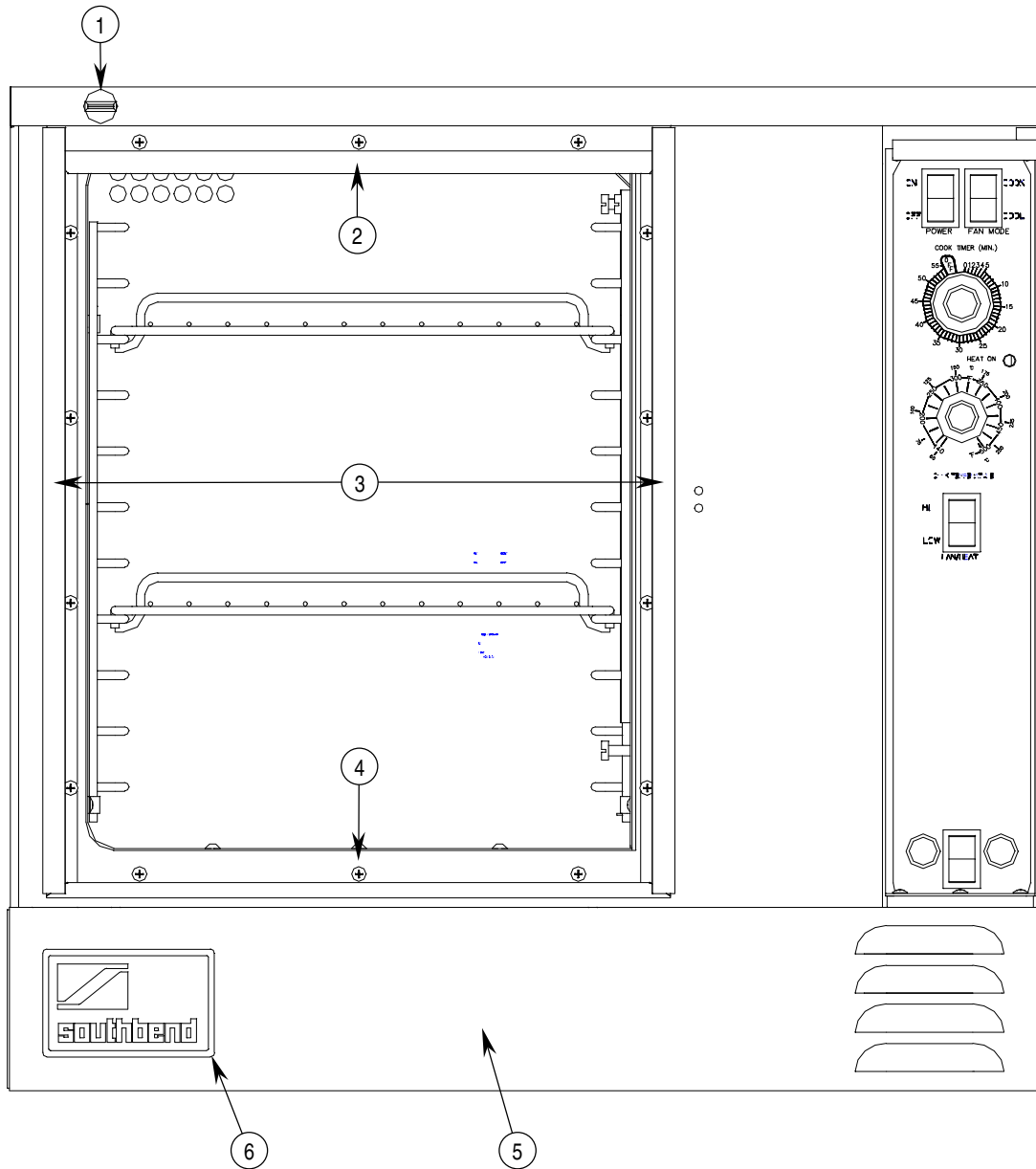

Key	Part Number	Qty	Description
1	1175401	1	Knob, black 1/40 w/set screw
2	1177481	1	Seal, top door
3	1177480	2	Seal, left & right door
4	1177496	1	Seal, bottom door
5	1181330	1	Panel, louver front
6	1172716	1	Nameplate, Southbend

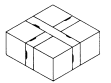

**Door, Door Latch, and Shutdown Switch Parts**

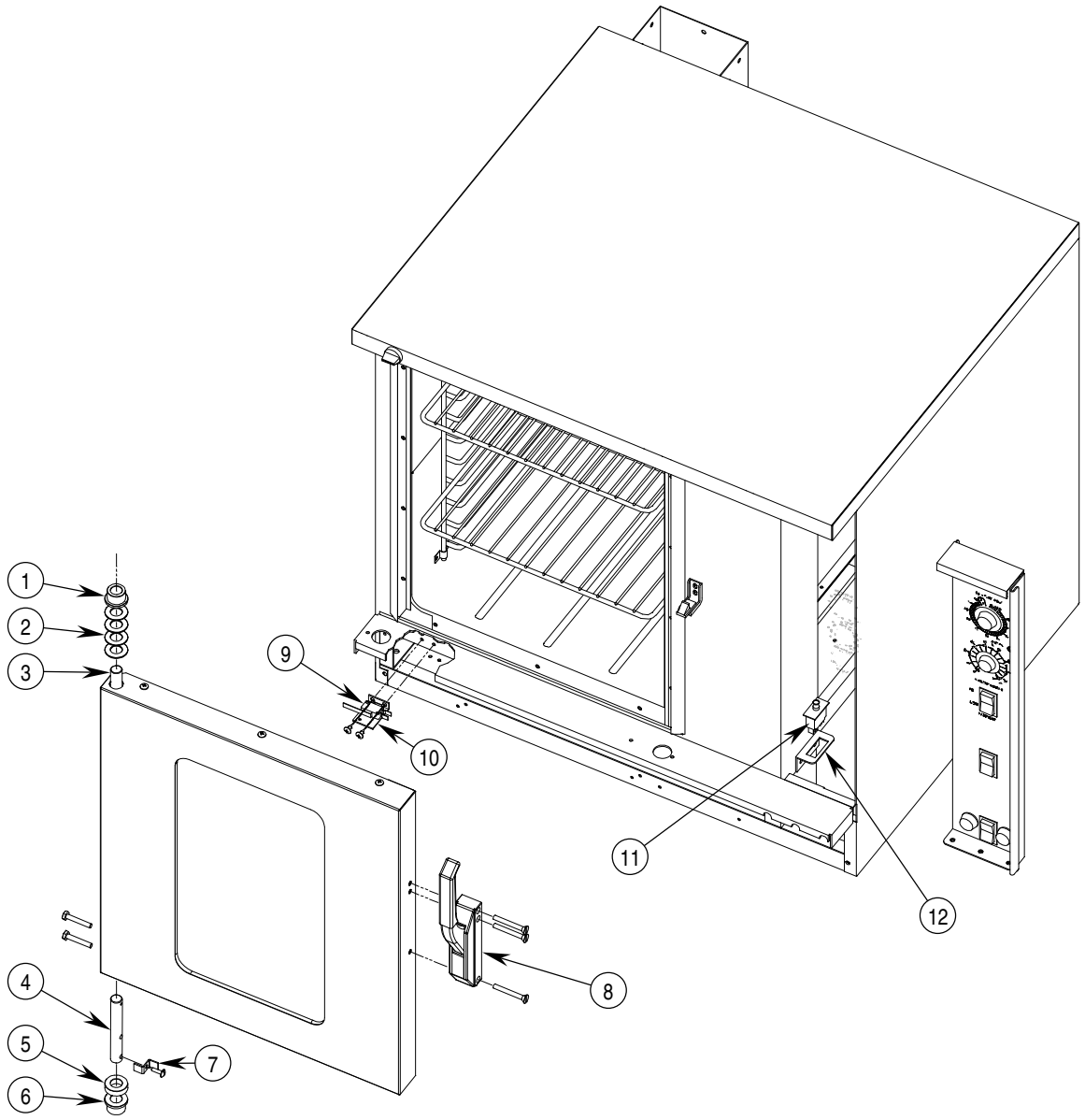

Key	Part Number	Qty	Description
1	1164527	1	Bushing-upper, bronze (Oilite)
2	1092000	4	Bearing-upper, thrust (Oilite)
3	1177550	1	Pin-upper, door
4	1177549	1	Pin-lower, door
5	1164547	1	Bearing-lower, thrust (Oilite)
6	1164527	1	Bushing-lower, bronze (Oilite)
7	1179899	1	Actuator, door switch
8	1180938	1	Latch & striker, door
9	1177567	1	Switch, door
10	1179900	1	Bracket, door switch
11	1177566	1	Switch, shutdown
12	1177495	1	Bracket, shutdown switch

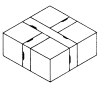

**Control Panel Parts for Models with Standard Controls (SC Models)**

See drawing on following page.

Key	Part Number	Qty	Description
1-17	1179707	1	Control panel s/a, SC, 60Hz, M-Gold, 208/380/415V (assembled, w/o wiring harness)
	1179656	1	Control panel s/a, SC, 60Hz, M-Gold, 480V (assembled, w/o wiring harness)
*	1179593	1	Wiring harness, SC
1	1177541	1	Rocker switch-DPST- (on-off)
2	1177540	2	Rocker switch-SPDT (on-on)
3	1170350	1	Light, amber, 240V, signal
4	6600334	2	Screw, 6-32, 3/8
5	1177785	1	Polypanel, M-Gold
6	1177556	1	Front control panel
7	1170424	2	Fuse holder
8	1170425	2	Fuse, 12 amp #LP-CC-12 low peak
9	1177642	1	Plug, square
10	1175046	1	Left control panel hinge
11	1170336	1	Marker strip
12	1170335	1	Terminal block
13	6600430	3	Locknut, 8-32
14	1146397	3	Screw 8-32 x 5/8 s/steel pan head
15	1181998	1	Cntl board/analog potentiometer
16	1175708	1	Buzzer, adjustable, 240VAC
17	1176416	1	Timer, motorized, 240V, 60Hz
	1176436	1	Timer, motorized, 240V, 50Hz
*	1172753	1	Thermostat probe (for units built before October 1, 2000)
	1181996	1	Thermostat probe (for units built on or after October 1, 2000)
*	1170337	2	Control knob
*	1166609	10	Ties, cable, ty-rap, 4"
* not shown on drawing.			

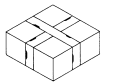

### Control Panel Parts for Models with Standard Controls (SC Models)

See parts list on previous page.

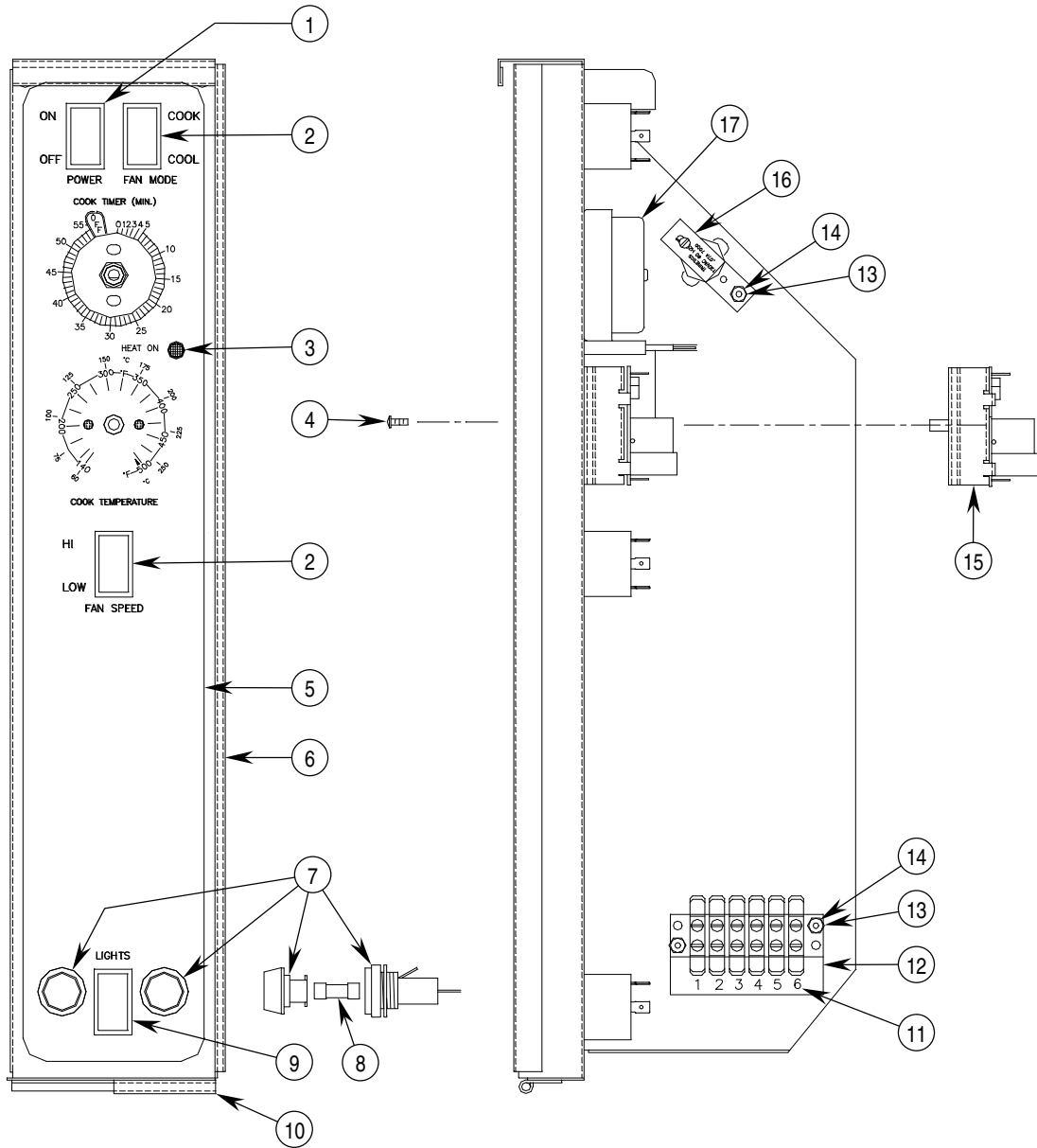

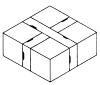

**Control Panel Parts for Cycle/Cook and Hold Models (CCH Models)**

See drawing on following page.

Key	Part Number	Qty	Description
1-16	1180487	1	Control panel s/a, CCH, 60Hz, M-Gold, 220/380/415V (assembled, w/o wiring harness)
	1180489	1	Control panel s/a, CCH, 60Hz, M-Gold, 480V (assembled, w/o wiring harness)
*	1180484	1	Wiring harness, CCH
1	1177541	1	Rocker switch-DPST- (on-off)
2	1177540	2	Rocker switch-SPDT (on-on)
3	1180350	1	Polypanel, CCH, M-Gold
4	1180479	1	Front control panel s/a, CCH
5	1170424	2	Fuse holder
6	1170425	2	Fuse, 12 amp #LP-CC-12 low peak
7	1177642	1	Plug, square
8	1175046	1	Left control panel hinge
9	1170336	1	Marker strip
10	1170335	1	Terminal block
11	6600430	4	Locknut, 8-32
12	1146397	4	Screw 8-32 x 5/8 s/steel pan head
13	1180404	4	Spacer, control
14	1180407	1	Control, CCH
15	1146400	4	Nut, #6-32 hex
16	1180499	1	Relay, 208/240V
*	1172753	1	Thermostat probe (for units built before October 1, 2000)
	1181996	1	Thermostat probe (for units built on or after October 1, 2000)
*	1166609	10	Ties, cable, ty-rap, 4"

\* not shown on drawing.

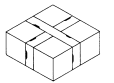

### Control Panel Parts for Cycle/Cook and Hold Models (CCH Models)

See parts list on previous page.

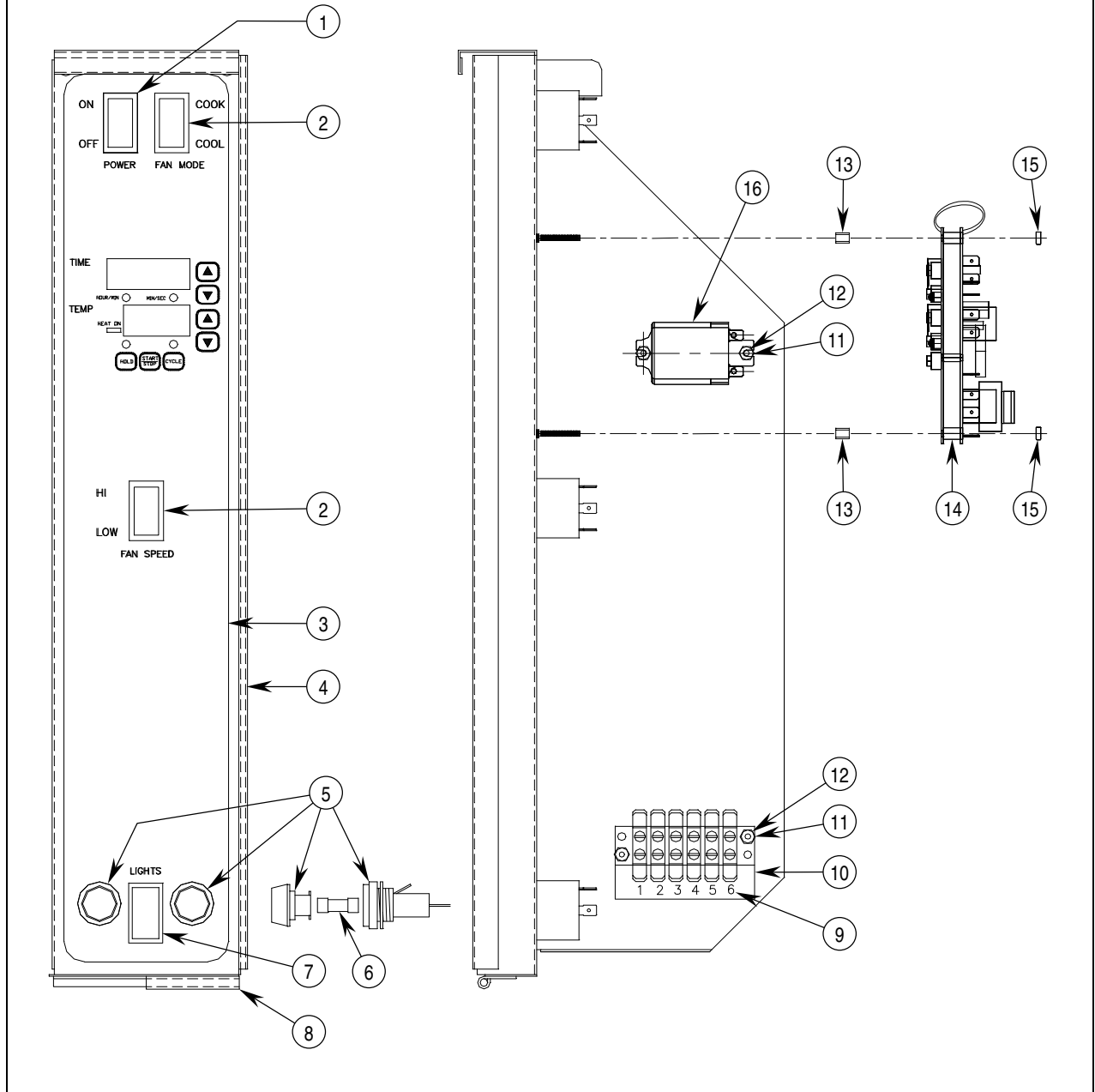

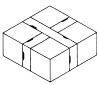

**Control Panel Parts for Models with Programmable Controls (PC Models)**

See drawing on following page.

Key	Part Number	Qty	Description
1-18	1179636	1	Control panel s/a, PC, 60Hz, M-Gold, 208/380/415V (assembled, w/o wiring harness)
	1179701	1	Control panel s/a, PC, 60Hz, M-Gold, 480V (assembled, w/o wiring harness)
*	1179635	1	Wiring harness, PC
1	1177541	1	Rocker switch-DPST- (on-off)
2	1170350	1	Light, amber, 240V, signal
3	1177786	1	Polypanel programmable control
4	1179706	1	Digital control panel w/a
5	1170424	2	Fuse holder
6	1170425	2	Fuse, 12 amp #LP-CC-12 low peak
7	1177642	1	Plug, square
8	1175046	1	Left control panel hinge
9	1170336	1	Marker strip
10	1170335	1	Terminal block
11	6600430	2	Locknut, 8-32
12	1146397	2	Screw 8-32 x 5/8 s/steel pan head
13	1179702	1	Harness, contactor PC/RT
14	1172271	1	Programmable control
15	1146400	4	Nut, 36-32 hex
16	1161525	2	Contactactor, two pole, 240V
17	1175742	1	Mount, motor contactactor
18	1146399	4	Screw, #10x1/2 philips truss (blunt)
*	1172753	1	Thermostat probe (for units built before October 1, 2000)
	1181996	1	Thermostat probe (for units built on or after October 1, 2000)
*	1172275	2	Control knob
*	1166609	10	Ties, cable, ty-rap, 4"
* not shown on drawing.			

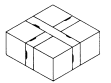

### Control Panel Parts for Models with Programmable Controls (PC Models)

See parts list on previous page.

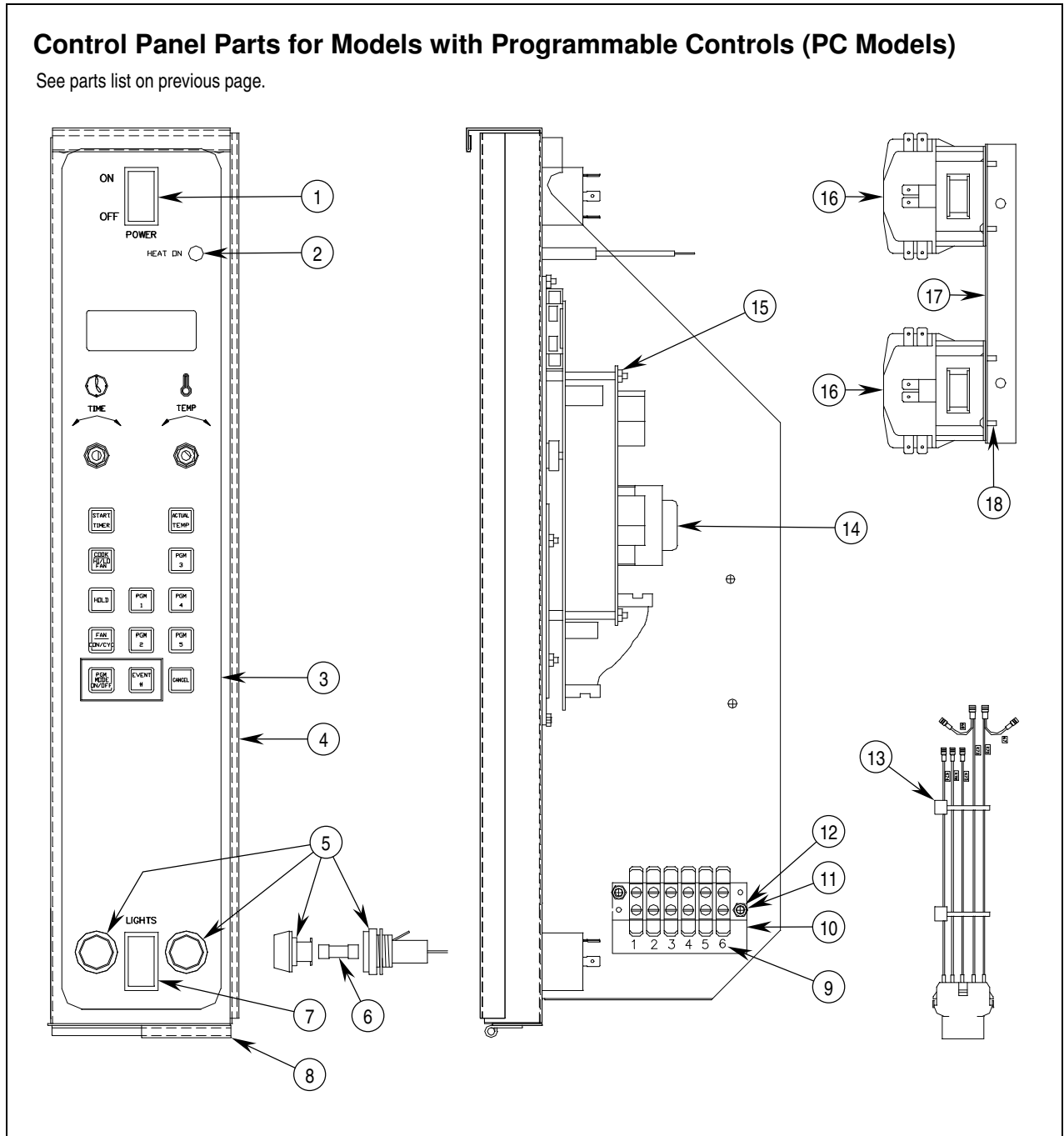

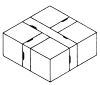

**Control Panel Parts for Models with Rack Timer Controls (RT Models)**

See drawing on following page.

Key	Part Number	Qty	Description
1-18	1179699	1	Control panel s/a, RT, 60Hz, M-Gold, 208/380/415V (assembled, w/o wiring harness)
	1179708	1	Control panel s/a, RT, 60Hz, M-Gold, 480V (assembled, w/o wiring harness)
*	1179635	1	Wiring harness, RT
1	1177541	1	Rocker switch-DPST- (on-off)
2	1170350	1	Light, amber, 240V, signal
3	1177787	1	Polypanel rack track
4	1179706	1	Digital control panel w/a
5	1170424	2	Fuse holder
6	1170425	2	Fuse, 12 amp #LP-CC-12 low peak
7	1177642	1	Plug, square
8	1175046	1	Left control panel hinge
9	1170336	1	Marker strip
10	1170335	1	Terminal block
11	6600430	2	Locknut, 8-32
12	1146397	2	Screw 8-32 x 5/8 s/steel pan head
13	1179702	1	Harness, contactor PC/RT
14	1173402	1	Rack track control
15	1146400	4	Nut, 36-32 hex
16	1161525	2	Contactactor, two pole, 240V
17	1175742	1	Mount, motor contactactor
18	1146399	4	Screw, #10x1/2 philips truss (blunt)
*	1172753	1	Thermostat probe (for units built before October 1, 2000)
	1181996	1	Thermostat probe (for units built on or after October 1, 2000)
*	1172275	2	Control knob
*	1166609	10	Ties, cable, ty-rap, 4"
* not shown on drawing.			

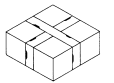

### Control Panel Parts for Models with Rack Timer Controls (RT Models)

See parts list on previous page.

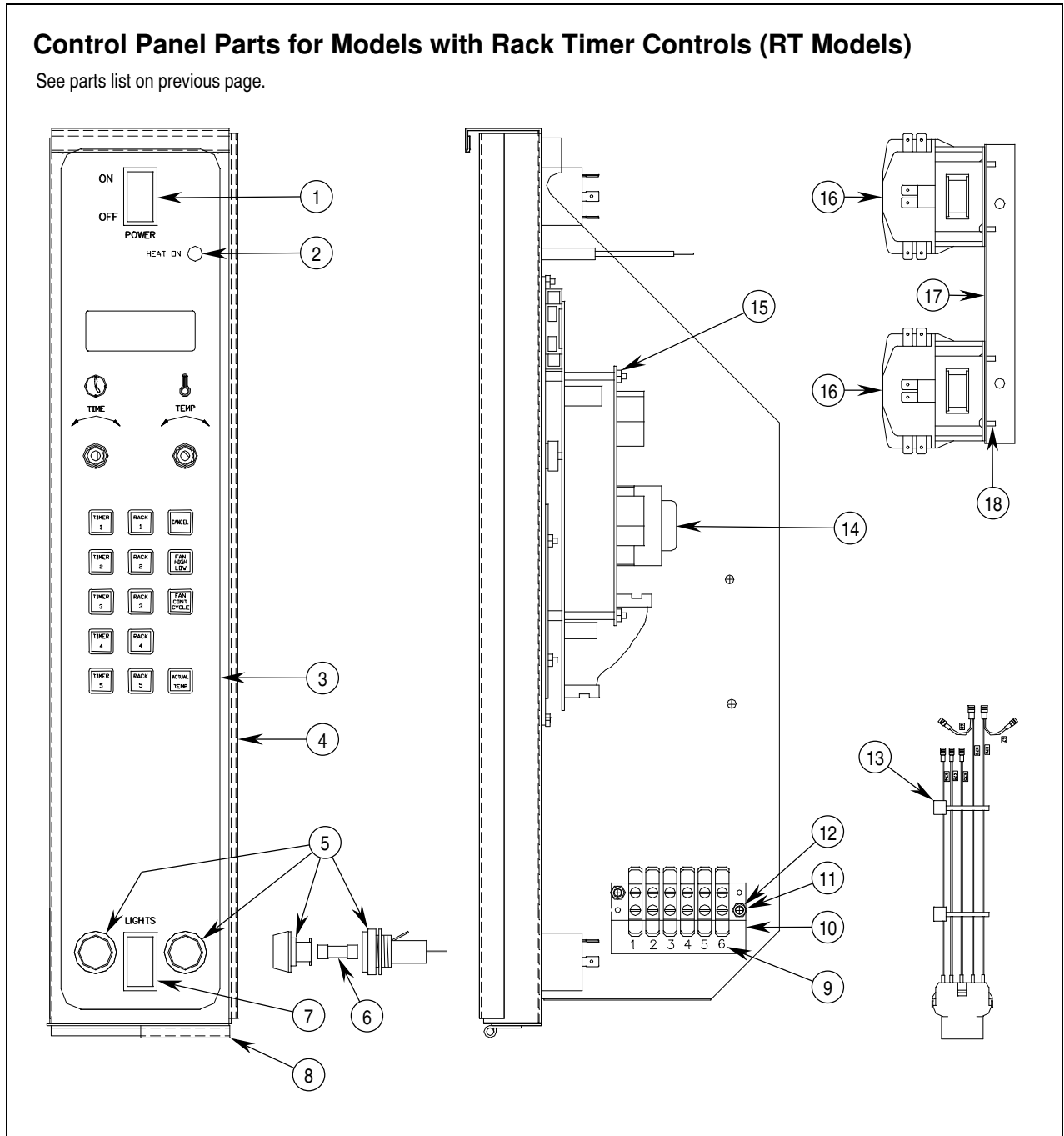

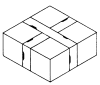

**Oven Interior and Side-Compartment Parts**

See drawing on following page.

Key	Part Number	Qty	Description
1	1177472	2	Rack, guide 11 position
2	1177469	2	Rack, oven
3	6660	8	Clip, side rack support
4-7	1178092	1	Complete element assembly, 208V
	1178093	1	Complete element assembly, 240V
	1178094	1	Complete element assembly, 380V
	1178095	1	Complete element assembly, 480V
4	1178088	3	Element, heating, 208V
	1178089	3	Element, heating, 240V
	1178090	3	Element, heating, 380V
	1178091	3	Element, heating, 480V
5	1178079	2	Clamp, heating element
6	1178078	2	Bracket, heating element
7	1078077	1	Plate, element mounting, EH
8	1177498	2	Support assembly, top baffle
9	1177511	1	Baffle, air enamel
10	1177494	2	Support assembly, bottom baffle
11	1175734	1	Plate, contactor mounting
12	1179680	1	Contact, element
13	1177523	1	Bracket, rear gas pipe
14	1179794	1	Fan, cooling 230V
15	1179710	4	Spacer, blower motor
16	1146264	4	Screw, motor mounting 1/4" x 2.00 lg.
17	1179689	1	Motor assembly, 208/230V, 50/60Hz, GH & EH
18	1177518	1	Blower pocket assembly
19	1177581	1	Blower wheel assembly, EH
*	1179100	**	Puller disk
20	1179839	1	Cover, electric element
21	1177577	1	Cover assembly, rear exhaust

\* not shown on drawing.

\*\* not part of oven; may be needed to remove blower wheel.

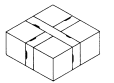

### Oven Interior and Side-Compartment Parts

See parts list on previous page.

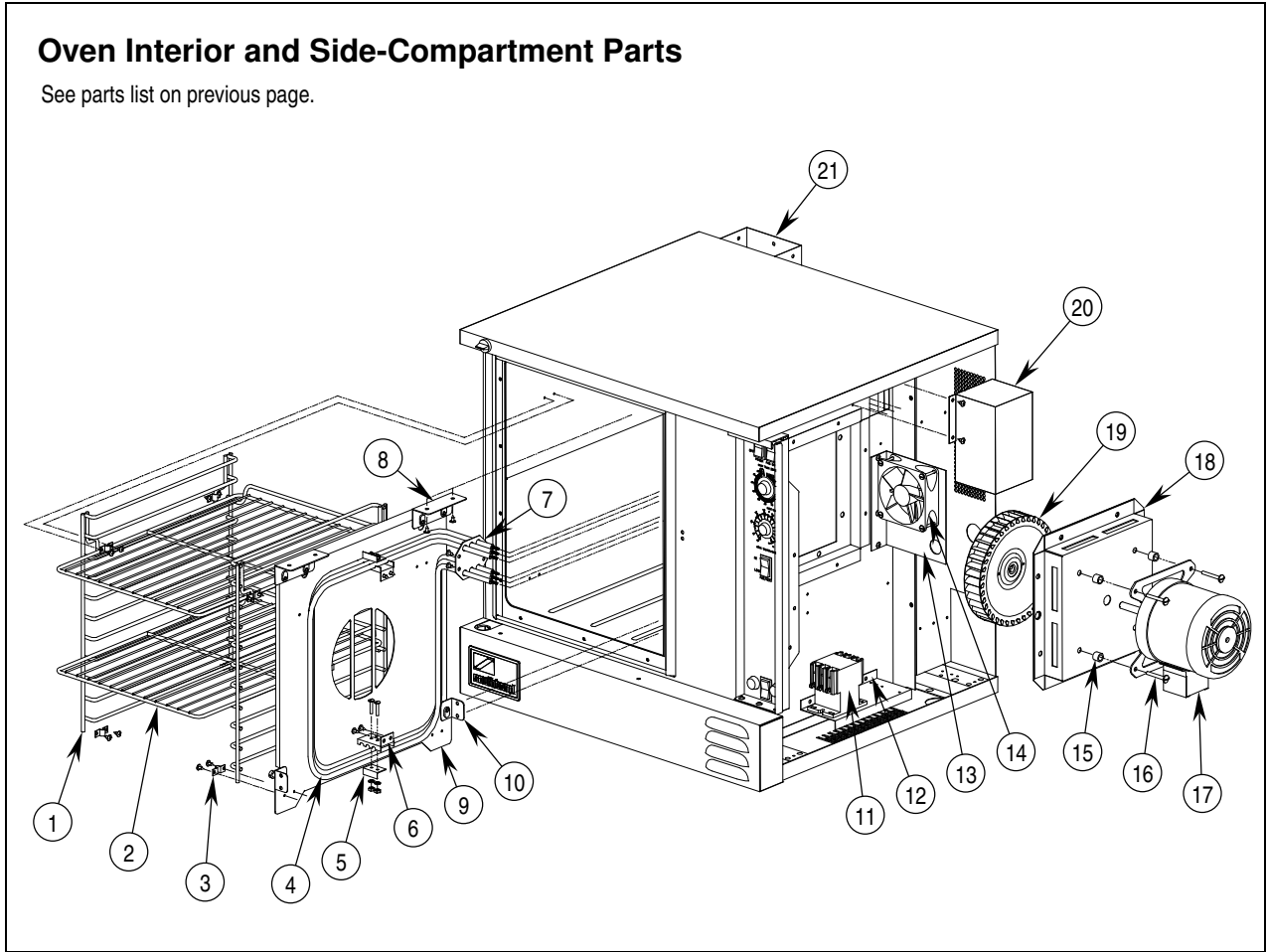

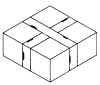

Leg Parts for Single-Deck Models

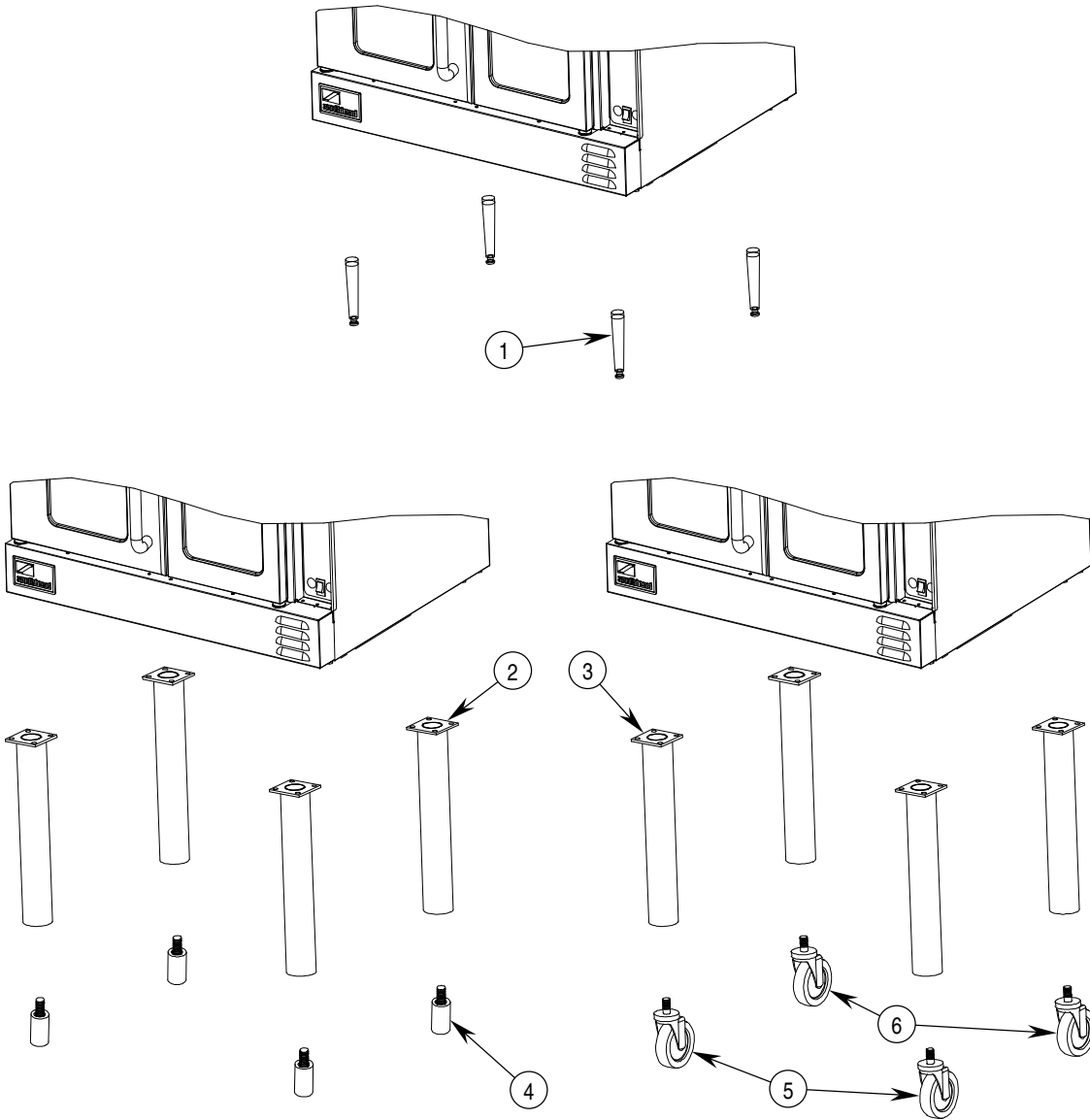

Key	Part Number	Qty	Description
1	1172857	1	4" legs (set of 4)
2	1175090	4	Single deck leg, M-Gold (for legs with feet)
3	1175089	4	Single deck leg, M-Gold (for legs with casters)
4	1174266	4	Adjustable foot for leg
*	1173584	4	Flanged foot (optional replacement for adjustable foot 1174266)
5	1174264	2	Caster with brake
6	1174263	2	Caster without brake
*	1174265	1	Set of four casters (two with brake, two without brake)
*	1146213	16	3/8 x 16 x 1 hex head bolt
*	1146513	16	3/8 lock washer
*	1146522	16	3/8 flat washer

\* not shown on drawing.

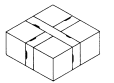

**Storage Rack Parts**

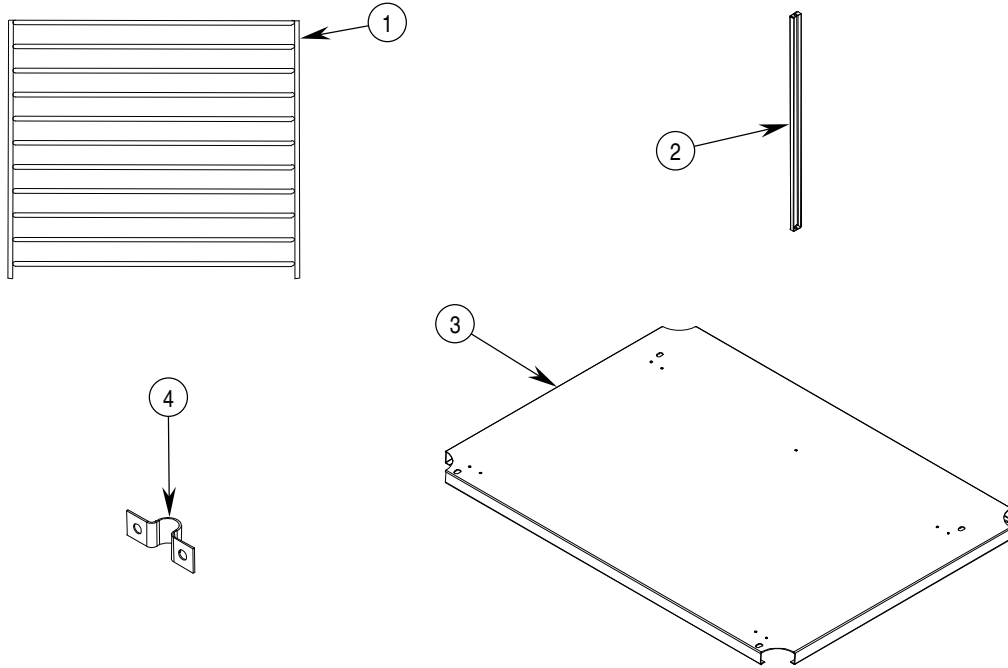

Key	Part Number	Qty	Description
1-4	0-75-0539	1	Cooling rack kit
1	1177472	2	Rack guide, 11 pos.
2	1181982	1	Stop channel
3	1181981	1	Shelf, open rack
4	6660	8	Clip, side rack support
*	1146304	18	10 x 1/2 Phillips screw
* not shown on drawing.			

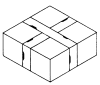

Double-Deck Oven Stacking Parts

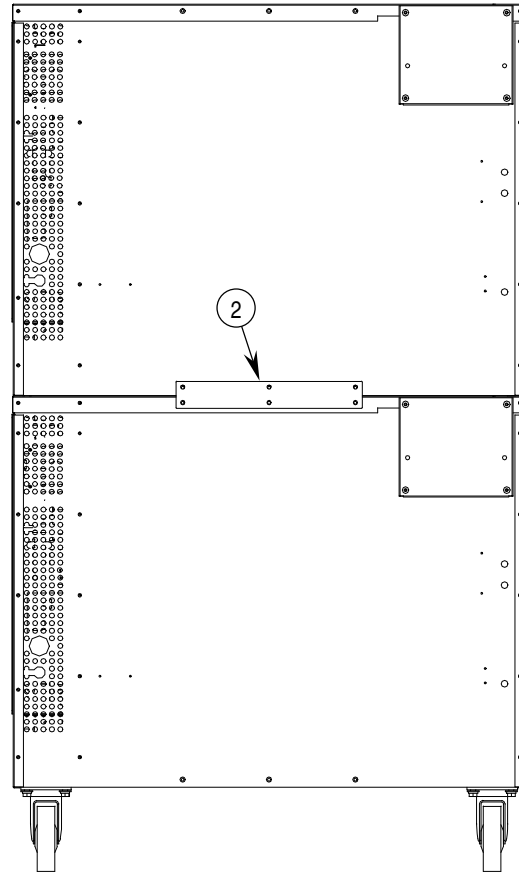
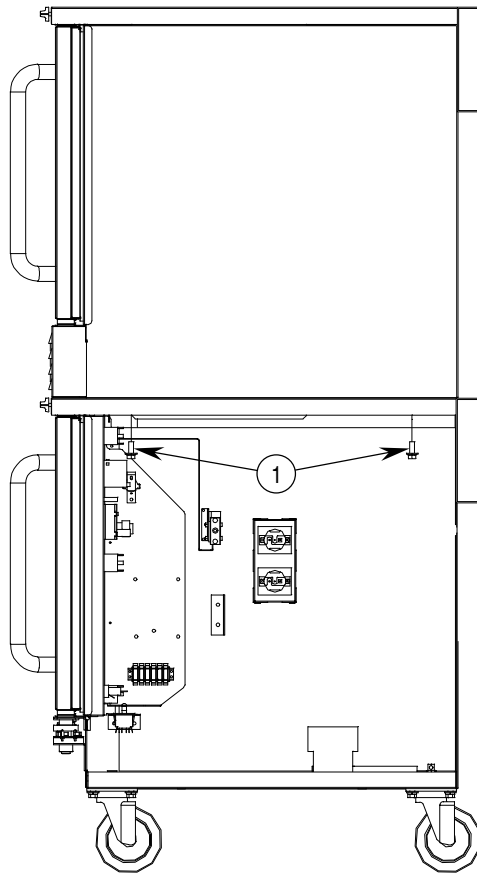

Key	Part Number	Qty	Description
1	1146213	2	Bolts
2	1175085	1	Tie bracket

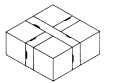

**Leg Parts for Double-Deck Ovens**

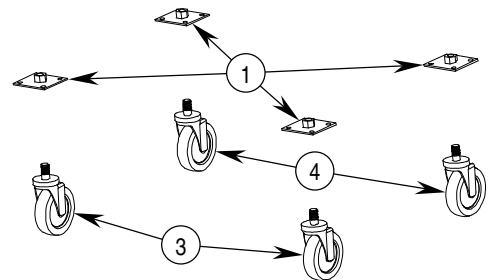
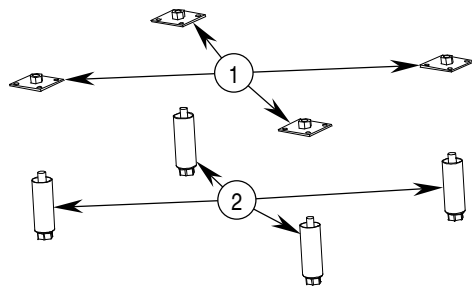
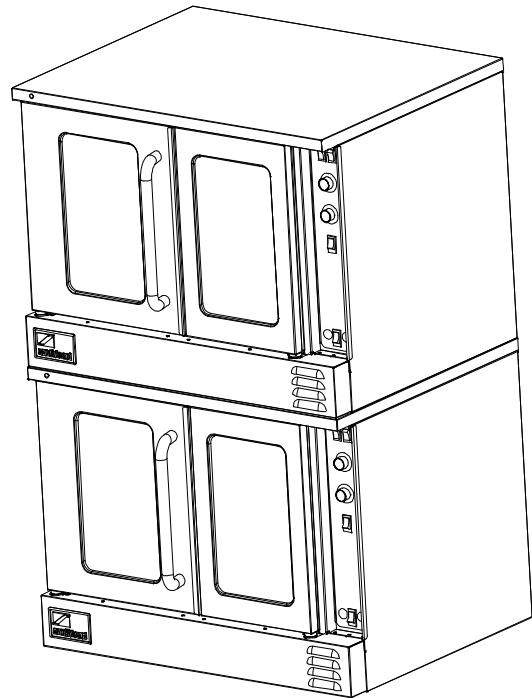
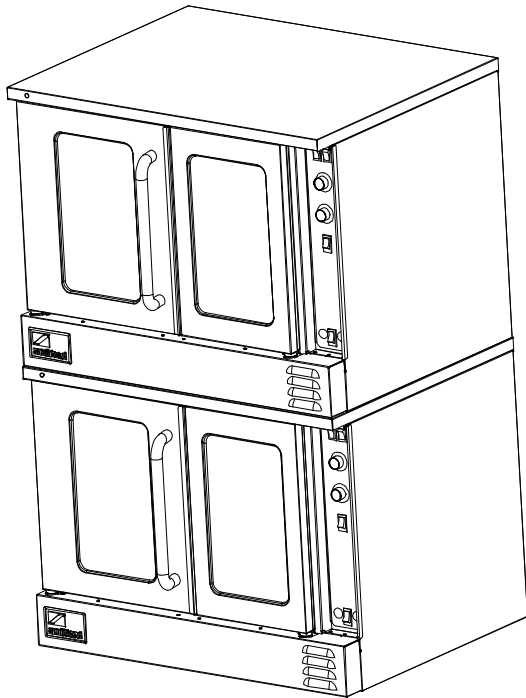

Key	Part Number	Qty	Description
1	1172788	4	Leg pad
2	1174259	4	SS leg, 3/4" stud
*	1174260	1	Leg package (set of four legs only)
3	1174264	2	Caster with brake
4	1174263	2	Caster without brake
*	1174265	1	Set of four casters (two with brake, two without brake)
*	1146213	16	3/8 x 16 x 1 hex head bolt
*	1146513	16	3/8 lock washer
*	1146522	16	3/8 flat washer

\* not shown on drawing.

Notes:

HALF-SIZE ELECTRIC CONVECTION OVENS

Notes:

Notes:

HALF-SIZE ELECTRIC CONVECTION OVENS

Notes:

# Marathoner Gold HALF-SIZE ELECTRIC CONVECTION OVENS



Commercial Food Equipment Service Association



A product with the Southbend name incorporates the best in durability and low maintenance. We all recognize, however, that replacement parts and occasional professional service may be necessary to extend the useful life of this unit. When service is needed, contact a Southbend Authorized Service Agency, or your dealer. To avoid confusion, always refer to the model number, serial number, and type of your unit.



Southbend  
1100 Old Honeycutt Road, Fuquay-Varina, NC 27526  
[www.southbendnc.com](http://www.southbendnc.com)