



TOWN



TOWN FOOD SERVICE EQUIPMENT CO., INC.

72 BEADEL STREET, BROOKLYN, NY 11222

Ph. (718) 388-5650

Fax (718) 388-5860

(800) 221-5032

www.townfood.com

SR-24-C 16" CANTONESE CHAMBER WOK RANGE



GENERAL

The SR-24-C utilizes Town's heavy duty stock pot stove body coupled with a powerful burner to offer true Asian cooking power in minimal space and without the need for water cooling. A Town 3 ring burner is supplied with this unit. Jet style burner choices are available; refer to our burner cut sheet for selection. The unit is supplied with Town's exclusive clog resistant pilot. An aluminized heat shield between the combustion chamber and outer body insures cool operation of the unit. Delta T rated solid brass valves with a solid metal handles are standard. The outer body and legs are stainless steel. A rugged interior chassis, formed from heavy duty steel angle iron is standard. Rear gas connection, pressure regulator and a galvanized drip tray are standard.

MODEL

SR-24-C is available for use with either Natural or Propane fuel. It is designed for use with 18"-20" Cantonese style woks. It can be converted for use as a stock pot range by purchasing a grate top.



STANDARD FEATURES

- Design certified by ETL for conformance to ANSI Z83.11-2007
- Design certified by NSF and /or ETL for conformance to ANSI/NSF-4
- Heavy duty 16" steel wok chamber, black epoxy painted finish
- Interior heat shield
- Solid brass valve - Delta T rated
- All Stainless Steel exterior construction
- Rugged, durable angle iron chassis
- High power 3 ring burner with two control valves for maximum heat control
- Clog resistant standing pilot/with control valve
- Stainless steel legs with bullet adjusters
- 3/4" NPT rear gas connection with regulator
- MEA and MA Plumbing Board Approved

OPTIONS

- Volcano, shield (duck) tip ,23 tip and 32 tip jet burners are available
- Custom leg height
- Double insulated chassis
- Castors with cross bracing
- Stainless steel drip pan
- Pilot gas safety system
- Asian smallwares, such as woks, ladles and shovels are available.

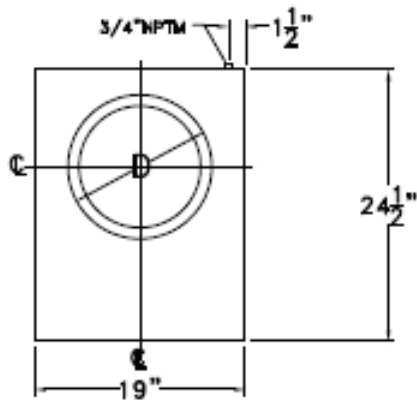

SR-24-C-CANTONESE RANGE

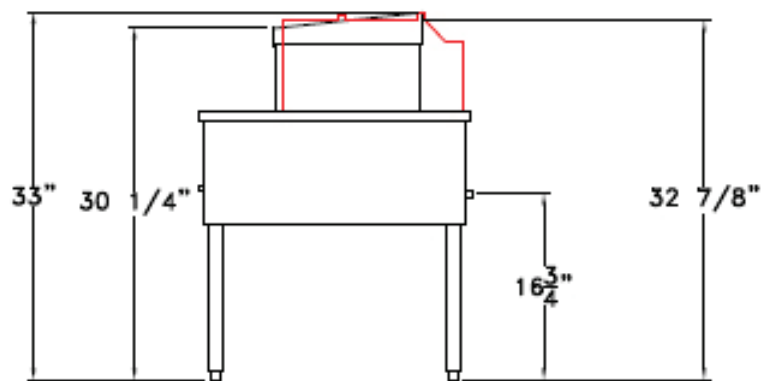
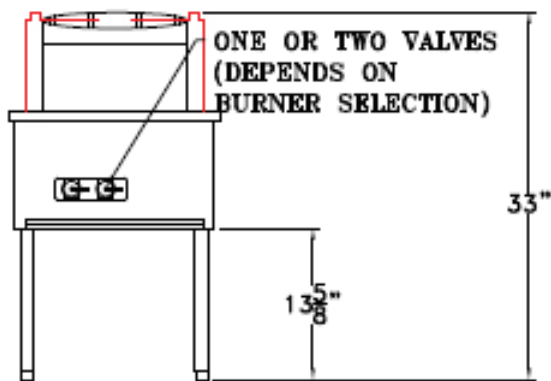

IMPORTANT

Commercial gas range(s) must be installed in accordance with state and local codes, or in the absence of local code with the NATIONAL FUEL GAS CODE- ANSI Z223.1. COMPLIANCE WITH ALL CODES IS THE RESPONSIBILITY OF THE OWNER AND THE INSTALLER.

COMMERCIAL GAS UNITS NEED ADEQUATE VENTILATION SYSTEMS. REFER TO NATIONAL FIRE PROTECTION ASSOCIATION STANDARD NO 96- "VAPOR REMOVAL FROM COOKING EQUIPMENT"

CERTIFIED BY ETL TO CONFORM TO ANSI Z83.11- "GAS FOODSERVICE EQUIPMENT."
NOT INTENDED FOR HOUSEHOLD USE. FOR USE BY PROFESSIONALLY TRAINED PERSONNEL ONLY.

CERTIFIED BY ETL/NSF TO NSF4/ANSI-4-COMMERCIAL COOKING, RETHERMALIZATION AND HOT FOOD EQUIPMENT- "SANITATION."

MINIMUM CLEARANCES- COMBUSTIBLE AND NON COMBUSTIBLE:
Back Wall- 6" Left and Right Sides- 6" For use on non combustibile floors only.

Town reserves the right to change design without notification.