

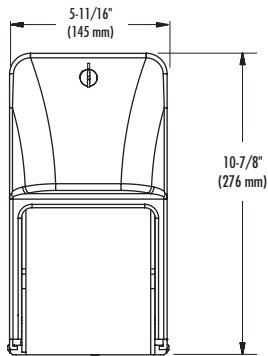

**5A10**



Designed with unique dual-curve geometry. Constructed of architectural satin finish stainless steel. Surface-mounted, Non-Controlled delivery toilet paper holder. Cabinet holds two rolls up to 4.5" W x 5.25" (114 x 133 mm) diameter standard core toilet paper. Molded polyethylene spindles. Unit measures 5.5625" W x 10.875" H x 6.1875" D (141 x 276 x 157 mm)



**505**

Controlled delivery. Chrome-plated, die-cast zinc. Unit features hinged arm with spring catch for filling and tension spring on fixed arm. Holds one (two) standard core roll(s) through 4.5" W x 5" (114 x 127 mm). Surface-mounted. Single roll. Unit measures 5.5" W x 2.375" H x 4.25" D (140 x 60 x 108 mm)

**522**

Double roll

Unit measures 10.5" W x 2.4375" H x 4.25" D (267 x 62 x 108 mm)

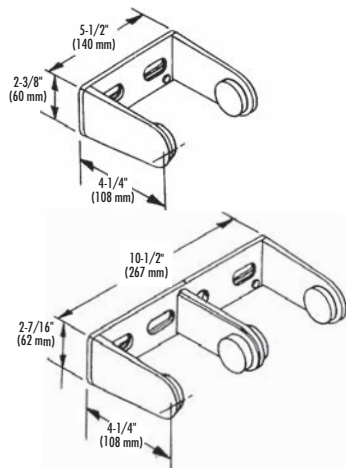

**5054**

Controlled delivery. Heavy-duty, Chrome-plated steel. Vandal-resistant locking mechanism. Hinged arm for filling. Tension spring prevents free spinning of roll. Holds one (two) standard core roll(s) through 6" (152 mm) in diameter. Surface-mounted. Single roll. Unit measures 6" W x 2.75" H x 4.5" D (152 x 70 x 114 mm)

**5224**

Double roll

Unit measures 12.375" W x 2.75" H x 4.3125" D (314 x 70 x 110 mm)

