



SG4 & SG6 Series Full Size Gas Convection Ovens

SG4D

ML-114875

SG4C

ML-114876

SG6D

ML-114877

SG6C

ML-114878

- NOTICE -

This Manual is prepared for the use of trained Hobart Service Technicians and should not be used by those not properly qualified.

This manual is not intended to be all encompassing. If you have not attended a Hobart Service School for this product, you should read, in its entirety, the repair procedure you wish to perform to determine if you have the necessary tools, instruments and skills required to perform the procedure. Procedures for which you do not have the necessary tools, instruments and skills should be performed by a trained Hobart Service Technician.

The reproduction, transfer, sale or other use of this manual, without the express written consent of Hobart, is prohibited.

This manual has been provided to you by ITW Food Equipment Group LLC ("ITW FEG") without charge and remains the property of ITW FEG, and by accepting this manual you agree that you will return it to ITW FEG promptly upon its request for such return at any time in the future.

TABLE OF CONTENTS

SERVICE UPDATES	4
SERVICE UPDATES	4
TIS DOCUMENT LIST - SG4D AND SG6D	4
GENERAL	6
INTRODUCTION	6
INSTALLATION	6
OPERATION	6
CLEANING	6
LUBRICATION	6
SPECIFICATIONS	6
TOOLS	6
REMOVAL AND REPLACEMENT OF PARTS	7
COMPONENT LOCATION	7
COVERS AND PANELS	7
CONTROL PANEL COMPONENTS	9
COMPONENT PANEL COMPONENTS	11
TEMPERATURE PROBE	13
GAS BURNERS	13
GAS ORIFICE	14
GAS SOLENOID VALVE	14
IGNITION CONTROL MODULE	15
SPARK IGNITER AND FLAME SENSE	16
BLOWER AND MOTOR ENDING AT SERIAL NUMBER 481913935	16
BLOWER AND MOTOR STARTING AT SERIAL NUMBER 481913936	18
OVEN DOORS AND BEARINGS ENDING AT SERIAL NUMBER 481907145	19
OVEN DOORS (INDEPENDENT DOORS) STARTING AT SERIAL NUMBER 481907146	20
ROLLER LATCH ASSEMBLY (INDEPENDENT DOORS)	20
DOOR CATCH ROLLER ASSEMBLY (INDEPENDENT DOORS)	21
DOOR WINDOW	21
INTERIOR LIGHTS (REAR MOUNTED, ROUND)	22
INTERIOR LIGHTS (SIDE MOUNTED, SQUARE)	22
DOOR SWITCH	24
HIGH LIMIT THERMOSTAT	25
COOLING FAN	25
SERVICE PROCEDURES AND ADJUSTMENTS	27
SOLID STATE TEMPERATURE CONTROLLER TEST (SG4D/SG6D)	27
SOLID STATE TEMPERATURE CONTROL CALIBRATION (SG4D/SG6D)	28
TEMPERATURE PROBE TEST (SG4D/SG6D)	29
COMPUTER CONTROLLER (SG4C/SG6C)	30
COMPUTER CONTROL CALIBRATION (SG4C/SG6C)	31
GAS PRESSURE ADJUSTMENT	31
VERIFICATION OF SPARK AT IGNITOR	32
DOOR SWITCH ADJUSTMENT	33
FLAME SENSE CURRENT TEST	33
BLOWER ADJUSTMENT	36
DOOR STRIKE ADJUSTMENT (INDEPENDENT DOORS)	36
DOOR CATCH ROLLER ADJUSTMENT	37
DOOR ADJUSTMENT	37
ELECTRICAL OPERATION	39
COMPONENT DESCRIPTION	39
SEQUENCE OF OPERATIONS	43
WIRING DIAGRAMS	48
SCHEMATICS	51

TRoubleshooting 53
 TRoubleshooting 53
 IGNITION MODULE DIAGNOSTICS 55

SERVICE UPDATES

SERVICE UPDATES

- BLOWER AND MOTOR Starting at Serial Number 481913936
- OVEN DOORS (INDEPENDENT DOORS) Starting at Serial Number 481907146
- INTERIOR LIGHTS (Rear Mounted, Round)
- INTERIOR LIGHTS (Side Mounted, Square)
- FLAME SENSE CURRENT TEST
- DOOR ADJUSTMENT
- WIRING DIAGRAMS
- SCHEMATICS
- COMPONENT DESCRIPTION

TIS DOCUMENT LIST - SG4D AND SG6D

SERVICE TAB

Document Title	Document Type
SG4D and SG6D Service Manual	Service Manual

SERVICE TAB (Multimedia)

Document Title	Document Type
Repair Flood-Damaged Food Equipment	Service Bulletin
SG4C, SG4D, SG6C, SG6D Gas Snorkel Convection Ovens Installation and Operation	I &O Manual
Fundamentals of Gas	Service Instructions
SG4 Gas Convection Oven Sequence of Operation	Service Video
TSB 1037A Hobart to Vulcan "Common" Model Cross Reference List	Technical Service Bulletin (TSB)
SG4 and 6 Convection oven High Limit Replacement	Technical Service Bulletin (TSB)
SG4 Gas Convection Oven Sequence of Operation	Service
Rating Plate Locations on Current Vulcan-Hart/Wolf Range Equipment	Service Bulletin
SG4 & SG6 Series Full Size Gas Convection Ovens	Service Manual
TSB 1133 SG4 & SG6 Series (Vulcan) Gas Convection Ovens Infinite Switch Troubleshooting	Technical Service Bulletin (TSB)
TSB 1301 Onwatch Quicklook 72 for Gas Cooking Equipment	Technical Service Bulletin (TSB)
Vulcan SG4 & SG6 Series Infinite Switch - Part # 411503-1, -2	Technical Service Instruction (TSI)

PARTS TAB (Multimedia)

Document Title	Document Type
Part Catalog for SG Series Gas Snorkel Convection Ovens After 8/6/04	Parts Catalog
Part Catalog for SG Series Gas Snorkel Convection Ovens Prior 8/6/04	Parts Catalog

DIAGRAMS TAB	
Document Title	Document Type
HGC5, DGC5, VC4G, WKGD Series	Wiring Diagram

GENERAL

INTRODUCTION

Procedures in this manual will apply to all models unless specified. Pictures and illustrations can be of any model unless the picture or illustration needs to be model specific. All models are equipped with a two-speed 1/2 HP electric motor, porcelain interior and two 30,000 BTU/hr burners as standard equipment. A power level control permits variable burner input from 15,000 BTU/hr to 60,000 BTU/hr.

Models SG4D and SG6D are equipped with solid state-controls and a 60-minute timer (a 5-hour timer is optional). Models SG4C and SG6C have a computer control with built-in Roast & Hold.

Models SG6D and SG6C have a 4" deeper cavity than models SG4D and SG4C.

INSTALLATION

Generally, installations are made by the dealer or contracted by the dealer or owner. Detailed installation instructions are included in the Installation & Operation Manual which is sent with each unit.

OPERATION

Detailed operation instructions are included with each oven.

CLEANING

Detailed cleaning procedures are included in the Installation & Operation Manual for the appropriate model.

LUBRICATION

Motor bearings are sealed and prelubricated.

SPECIFICATIONS

Electrical Data

Model	Volts	Hertz	Phase	Amps
SG4D	120	60	1	7.5
SG4C	208	60	1	3.6
SG6D	240	60	1	3.75
SG6C				

Gas Data

Model	Input BTU/hr		Manifold Pressure	
	Natural	LP Gas	Natural	LP Gas
SG4D				
SG4C				
SG6D	60,000	60,000	3.5" W.C. (0.9 kPa)	10" W.C. (2.2 kPa)
SG6C				

TOOLS

Standard

- Hand tools (standard set).
- VOM with AC current tester (any quality VOM with a sensitivity of at least 20,000 ohms per volt can be used).
- Gear puller to remove blower.

Special

- Temperature tester (thermocouple type).
- Manometer

REMOVAL AND REPLACEMENT OF PARTS

COMPONENT LOCATION

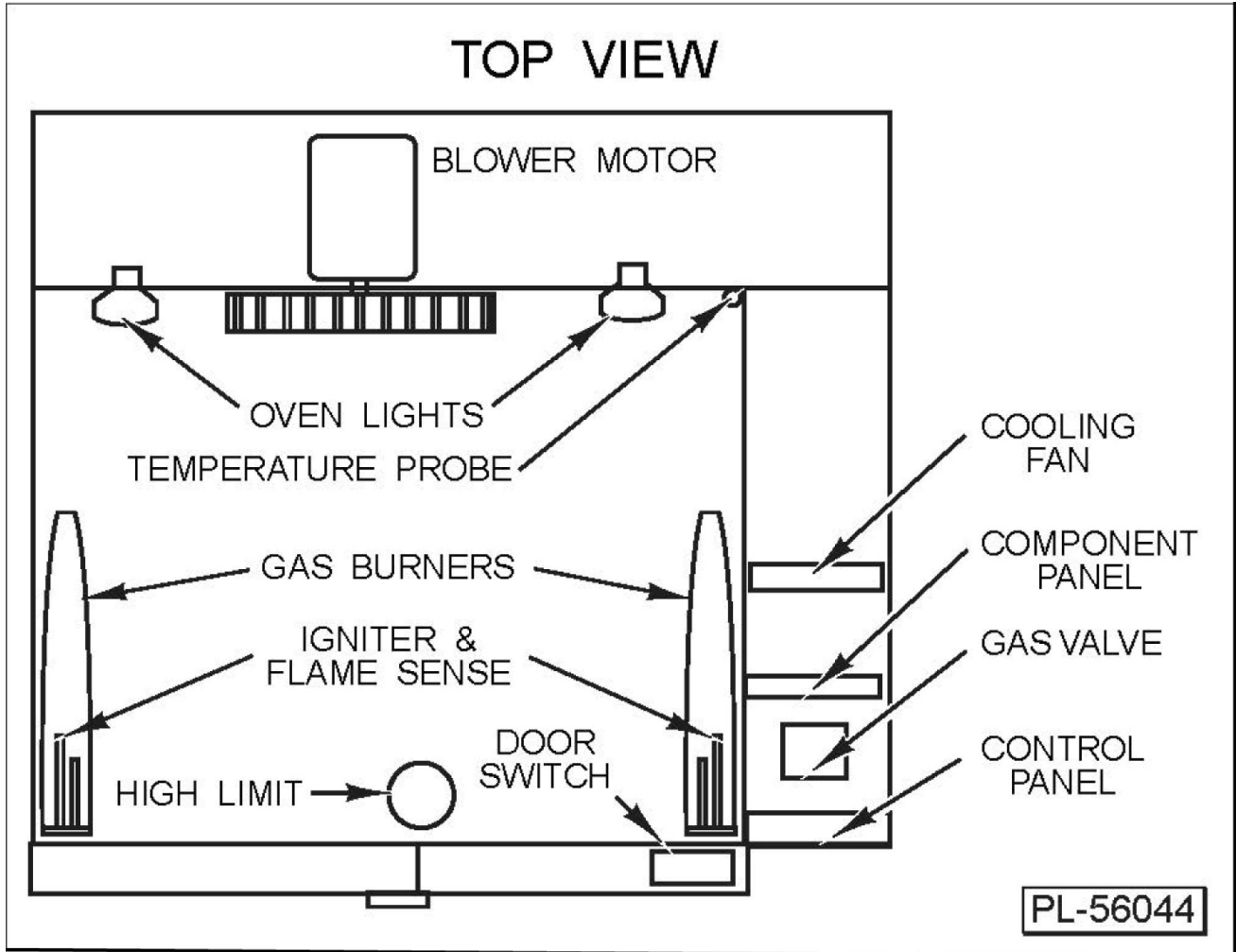

Fig. 1

COVERS AND PANELS



⚠ WARNING

Disconnect the electrical power to the machine and follow lockout / tagout procedures.

Top Front Cover

1. The top front cover is secured with four screws, two on each side of cover. Remove these screws, then remove the cover from the oven.

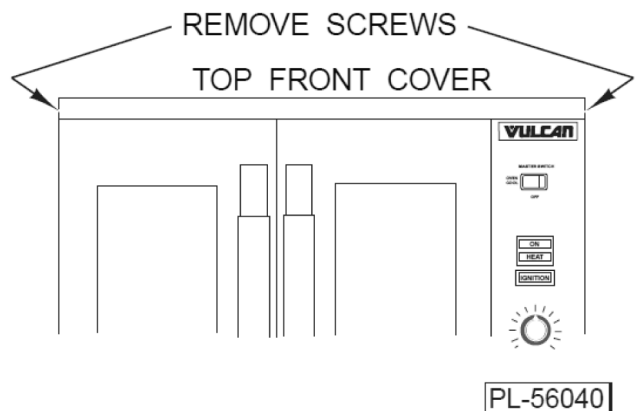

Fig. 2

- Reverse the procedure to install.

Bottom Front Cover

- The bottom front cover is secured with six screws, two on each side of cover and two on the top. Remove these screws then remove the cover from the oven.

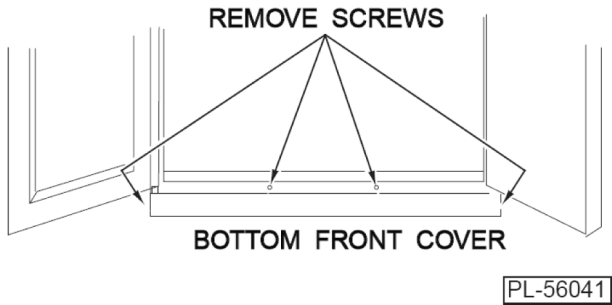

Fig. 3

- Reverse the procedure to install.

Control Panel

- Remove three screws on the right side which secure the control panel. Pull the panel away from the oven.

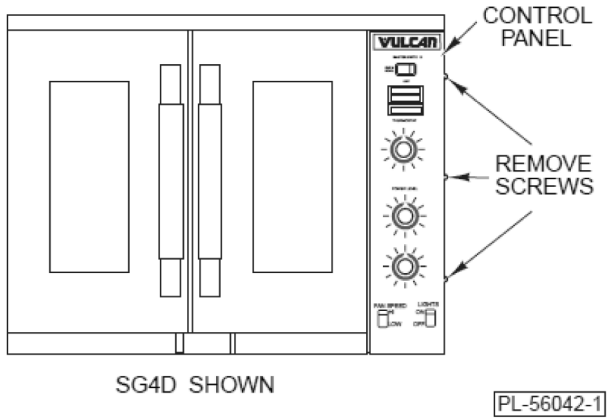

Fig. 4

- Disconnect the temperature probe leads from the solid state temperature controller.
- Unplug the wire harness connector to the control panel components.
- Reverse the procedure to install.

Right Side Panel

- Remove the screws that secure the right side of the control panel.
- Remove the remaining screws securing the right side panel.
- Pull the right-side panel out at the bottom then down to remove.

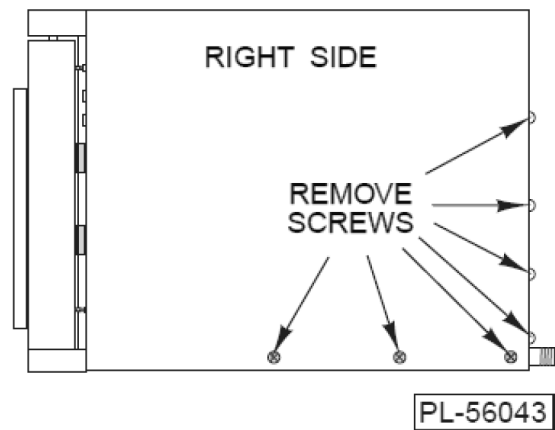
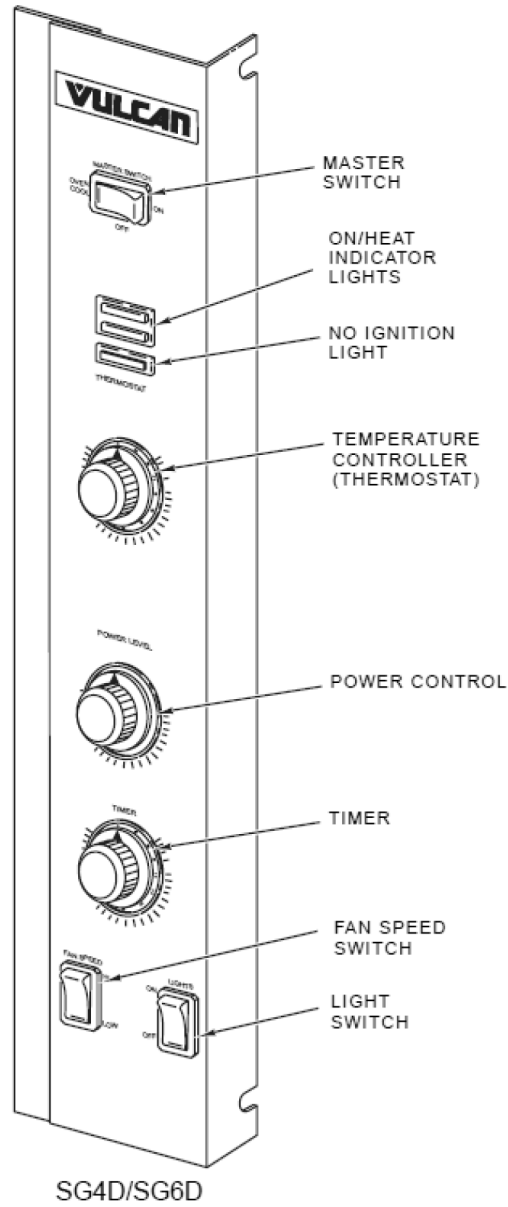

Fig. 5

- Reverse the procedure to install.

CONTROL PANEL COMPONENTS



PL-56045-1

Fig. 6

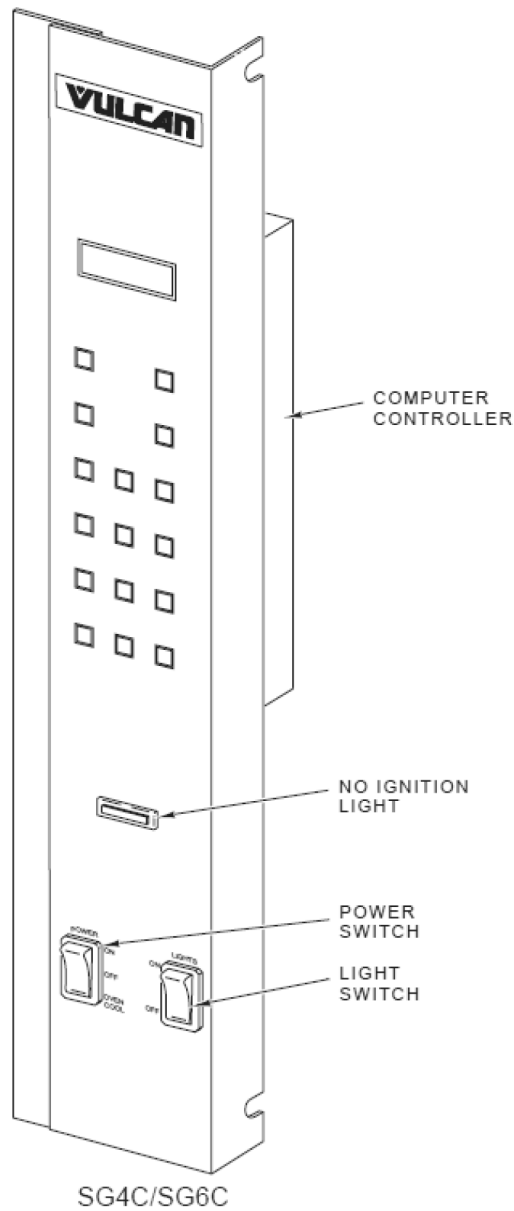

PL-56046

Fig. 7

Procedure



WARNING

Disconnect the electrical power to the machine and follow lockout / tagout procedures.

1. Remove the control panel as outlined under Covers and Panels.
2. Remove the component being replaced.
3. Reverse the procedure to install the new component, then check oven for proper operation.

COMPONENT PANEL COMPONENTS

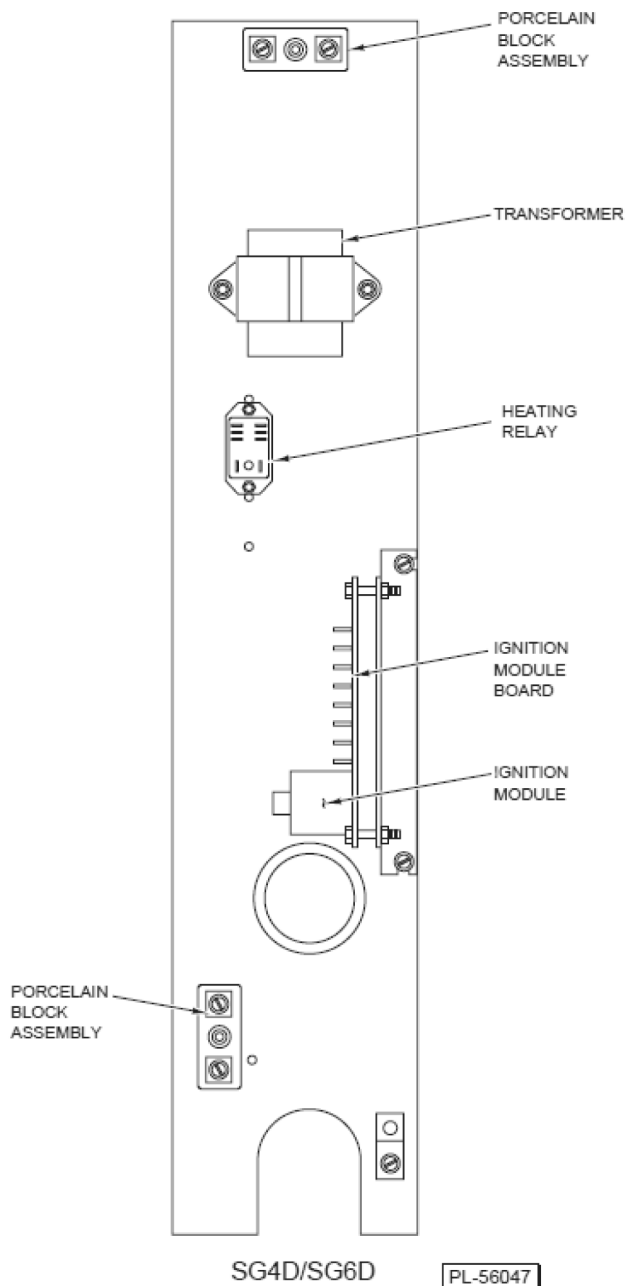
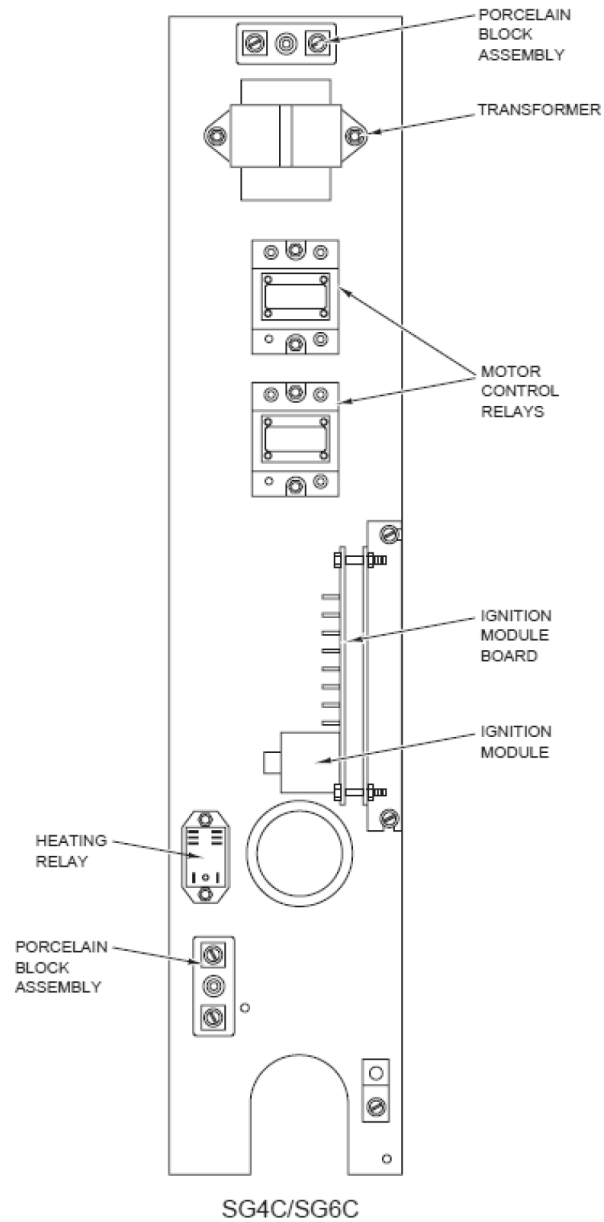

Fig. 8



PL-56048

Fig. 9

Procedure



WARNING

Disconnect the electrical power to the machine and follow lockout / tagout procedures.

1. Remove the right side panel as outlined under Covers and Panels.
2. Disconnect the wire leads to the component being replaced.
3. Remove the component.
4. Reverse the procedure to install the new component and check oven for proper operation.

TEMPERATURE PROBE



⚠ WARNING

Disconnect the electrical power to the machine and follow lockout / tagout procedures.

1. Remove the right-side panel as outlined under Covers and Panels.
2. Disconnect probe leads from the solid state temperature controller on the SG4D/SG6D or the computer controller on the SG4C/SG6C.
3. Remove the racks and right rack support.
4. Remove the upper and lower door seals.

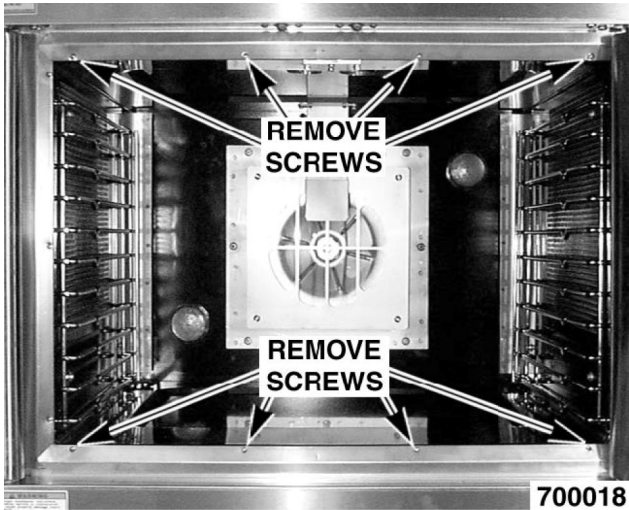

Fig. 10

5. Loosen the three screws securing the right side air scoop to the rear heat exchanger. Rotate the air scoop off of the heat exchanger tube into the oven cavity.
6. Remove the screws that secure the perforated side panel and lift out.

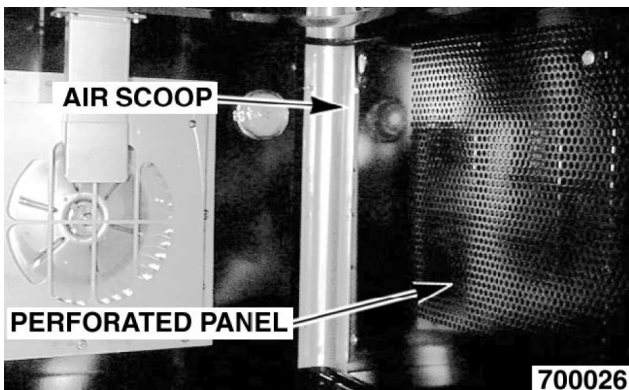

Fig. 11

7. Remove the probe from the bracket(s).

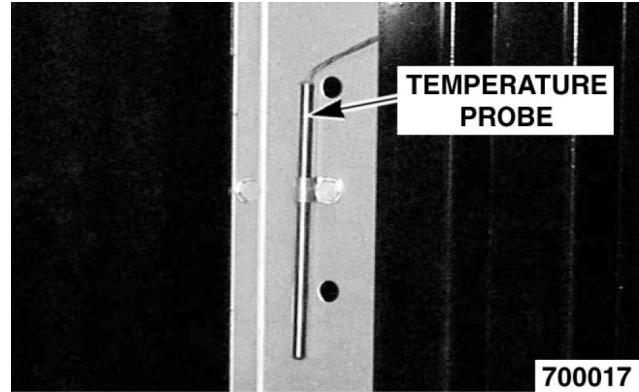

Fig. 12

SG4C/SG6C Temperature Probe Shown

8. Push the probe through the oven wall and into the control panel area.
9. Reverse the procedure to install the new probe.
10. Calibration:
 - A. SG4D/SG6D: Adjust the temperature controller as outlined under Solid State Control Calibration.
 - B. SG4C/SG6C: Adjust the computer controller as outlined under Computer Controller and/or Computer Controller Calibration in Service Procedures and Adjustments.

GAS BURNERS



⚠ WARNING

Disconnect the electrical power to the machine and follow lockout / tagout procedures.

⚠ WARNING

Shut off the gas before servicing the oven.

1. Remove the lower front cover as outlined under Covers and Panels.
2. There are two burners located on the bottom left and right side of the oven. Disconnect the ignition cable and the flame sense lead from each burner.

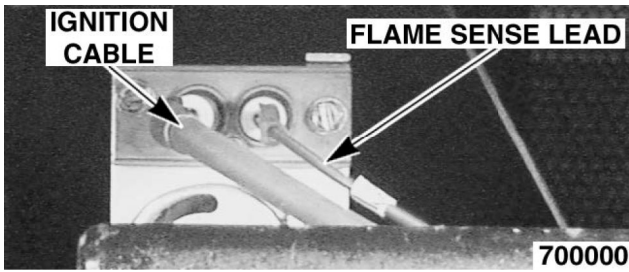

Fig. 13

- Remove the bolts securing the gas manifold and place manifold aside.



Fig. 14

- Grasp the burner and lift out.



Fig. 15

- Reverse the procedure to install and check for proper operation.
 - Ensure the spacers are in place on the ignition wires. The spacers are intended to keep the ignition wires from laying flat on the oven chassis.
 - Ensure that the bracket on the back of the burner is inserted into the slot at the rear of the burner chamber.

NOTE: Check the flame current by following the Flame Current Measurement procedures under the Procedures and Adjustments Section of this manual.

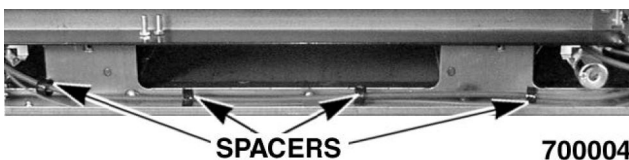

Fig. 16

GAS ORIFICE



⚠ WARNING

Disconnect the electrical power to the machine and follow lockout / tagout procedures.

⚠ WARNING

Shut off the gas before servicing the oven.

- Remove the lower front cover as outlined under Covers and Panels.
- Remove the bolts securing the gas manifold and place manifold aside.



Fig. 17

- There are two gas orifices on the manifold. Remove each orifice and replace with the correct orifice for the given altitude as needed.

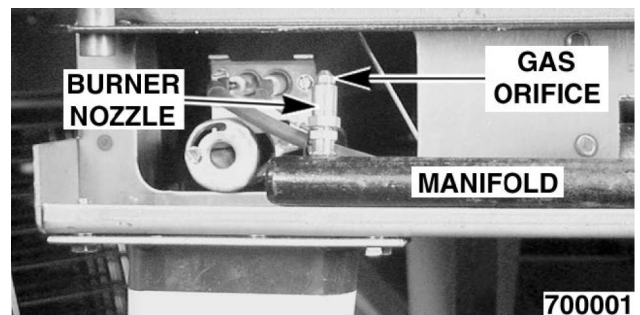

Fig. 18

- Reverse the procedure to install manifold and check for proper operation.

GAS SOLENOID VALVE



⚠ WARNING

Disconnect the electrical power to the machine and follow lockout / tagout procedures.

⚠ WARNING

Shut off the gas before servicing the oven.

- Remove the control panel and the right side panel as outlined under Covers and Panels.

2. Disconnect the lead wires.
3. Disconnect compression fittings from the valve.

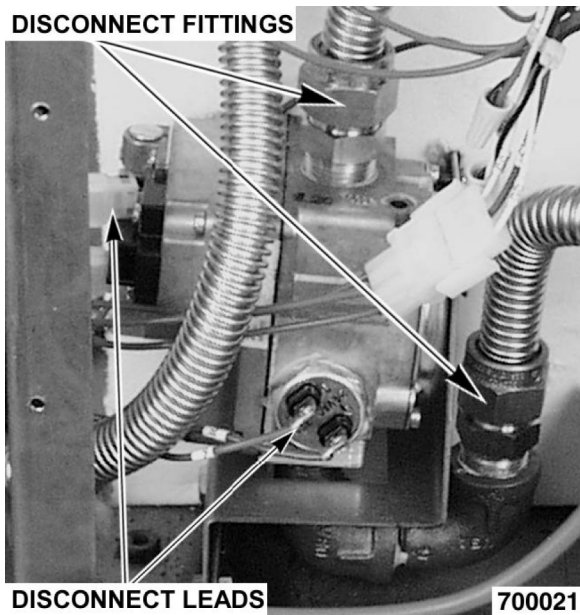

Fig. 19

4. Loosen the bolts securing the valve and bracket assembly, then remove the screws securing the valve to the bracket.

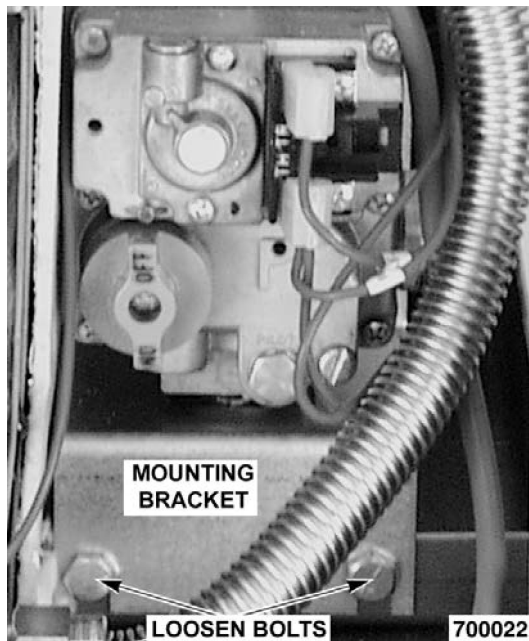

Fig. 20

5. Reverse the procedure to install the replacement gas valve.

⚠ WARNING

All gas joints disturbed during servicing must be checked for leaks. Check with soap and water solution (bubbles). Do not use an open flame.

6. Verify gas pressure as outlined under the Gas Pressure Adjustment in Service Procedures and Adjustments. Check for proper operation.

IGNITION CONTROL MODULE



⚠ WARNING

Disconnect the electrical power to the machine and follow lockout / tagout procedures.

1. Remove the right side cover as outlined under Covers and Panels.
2. Loosen the screws securing the mounting bracket to the component panel and remove the bracket.

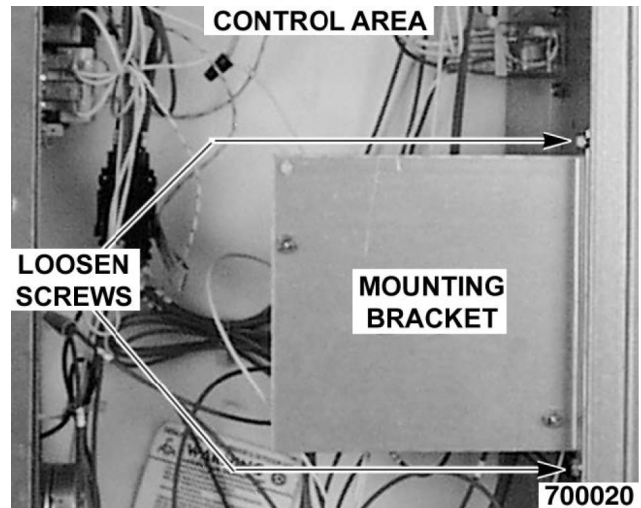

Fig. 21

3. Disconnect the lead wires and igniter cables from the ignition module board.

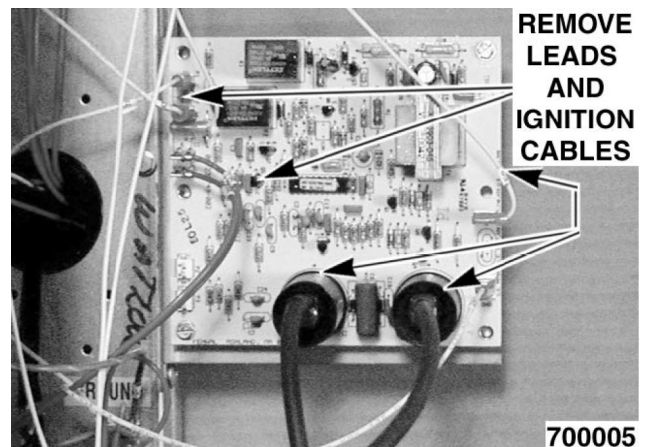

Fig. 22

4. Remove the ignition module board from the mounting bracket.

5. Reverse the procedure to install the replacement ignition module board.
6. Check for proper operation.

SPARK IGNITER AND FLAME SENSE



⚠ WARNING

Disconnect the electrical power to the machine and follow lockout / tagout procedures.

⚠ WARNING

Shut off the gas before servicing the oven.

1. Remove the two gas burners as outlined under Gas Burners.
2. Remove the screws securing the igniter and flame sense to each burner. Remove the assembly.

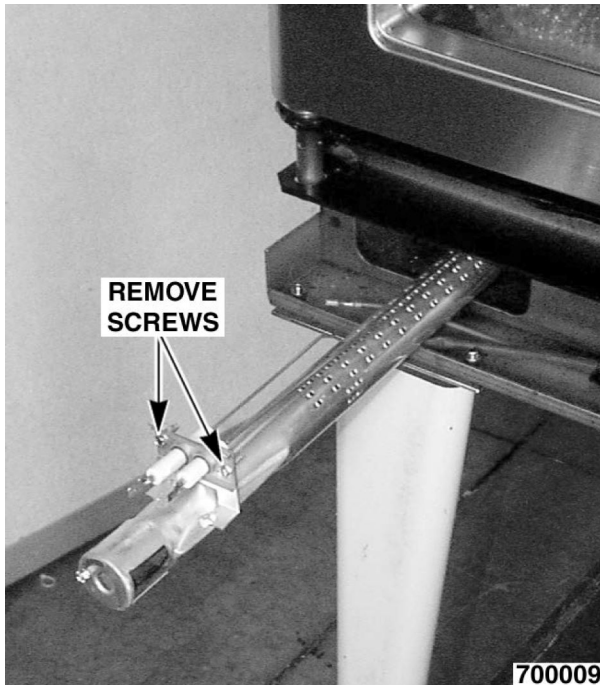

Fig. 23

3. The spark gap is 1/8" from the inside of the spark rod to the inside to the ground rod. The ground rod (the end of the spark) is 1/8" above the burner. If the gap is not correct or poor sparking is occurring, then adjust accordingly.

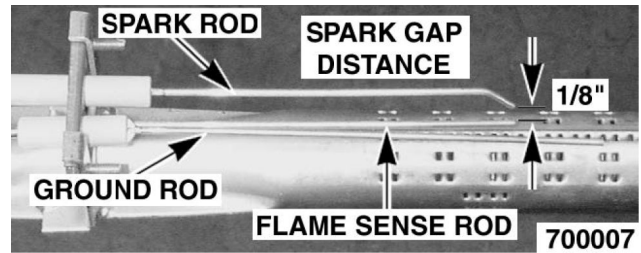

Fig. 24

4. Reverse the procedure to install the assembly and check for proper operation.

BLOWER AND MOTOR Ending at Serial Number 481913935



⚠ WARNING

Disconnect the electrical power to the machine and follow lockout / tagout procedures.

1. Remove racks.
2. Remove the screws securing the snorkel and remove the snorkel.

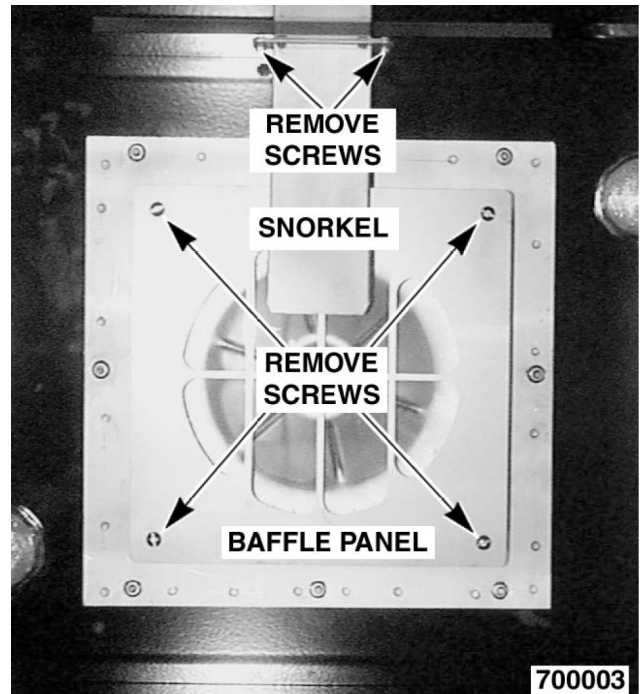

Fig. 25

3. Remove screws securing baffle panel and remove the panel.
4. If replacing:
 - A. **Blower Only** - Loosen set screws on blower hub and using a bearing puller, remove blower from motor shaft.

- 1) Reverse procedure to install and adjust blower position as outlined under the Blower Adjustment in Service Procedures and Adjustments section.

B. **Motor** - Perform step 4A and continue procedure.

5. Remove the screws that secure the motor mounting plate to the rear wall.

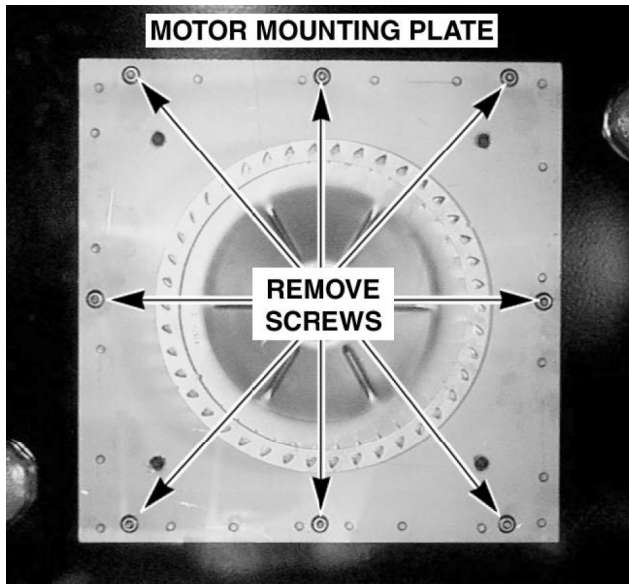

Fig. 26

6. Place a piece of cardboard on the bottom of the oven cavity to protect its surface from any damage during motor assembly removal.
7. Pull the motor assembly into the oven cavity and place it on the cardboard.
8. Remove the junction box cover from the motor, disconnect lead wires and remove the conduit.
9. Remove motor mounting bolts and flat washers, then lift the motor from the mounting plate.
10. Position the replacement motor on the motor mounting plate and install mounting bolts and washers. Hand tighten mounting bolts only.
11. Reconnect to lead wires at the motor, and replace conduit and junction box cover.

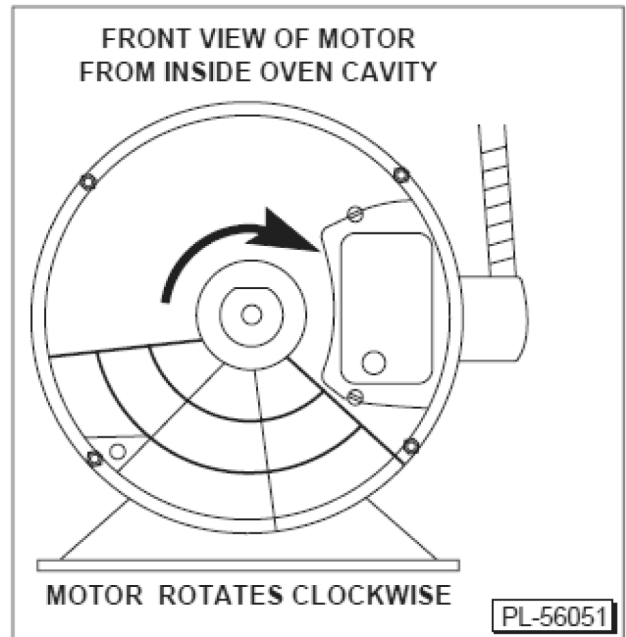

Fig. 27

12. Slide blower onto motor shaft until hub is flush with end of shaft, then tighten setscrews.
13. Adjust motor position until blower is parallel to motor mounting plate as outlined in Blower Adjustment under Service Procedures and Adjustments.
14. Position motor mounting plate on the rear wall and secure with nuts and washers.
15. Replace the baffle panel and snorkel.
16. Replace the air baffle on the rear wall at the lower right hand corner.
17. Remove cardboard from the bottom of the oven cavity.
18. Install racks.
19. Check oven for proper operation.

BLOWER AND MOTOR Starting at Serial Number 481913936



⚠ WARNING

Disconnect the electrical power to the machine and follow lockout / tagout procedures.



⚠ WARNING

Shut off the gas before servicing the unit and follow lockout / tagout procedures.

1. Remove RIGHT SIDE PANEL(S).
2. Disconnect motor harness (1, Fig. 28).

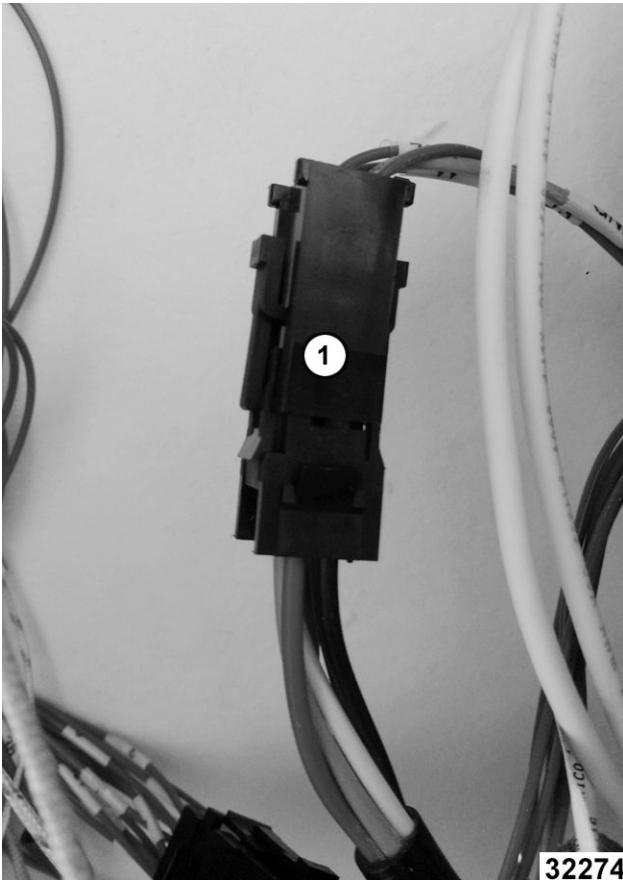

Fig. 28

3. Pinch cord grip together to remove from rear panel.

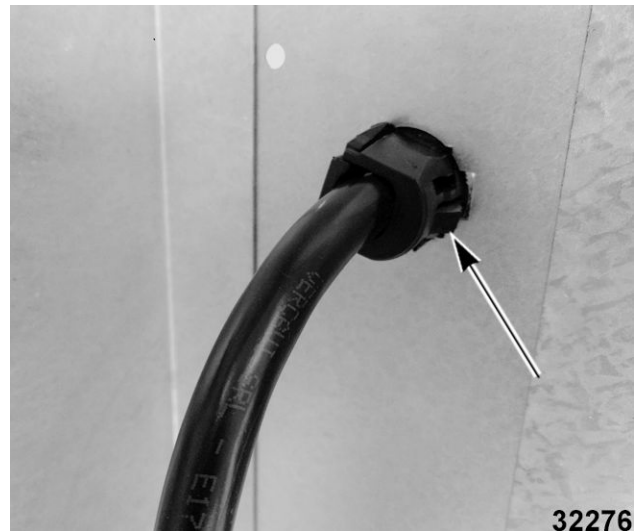

Fig. 29

4. Push motor wiring harness/cord out hole in rear panel.
5. Remove racks.
6. Remove screws securing "snorkel" and remove snorkel.

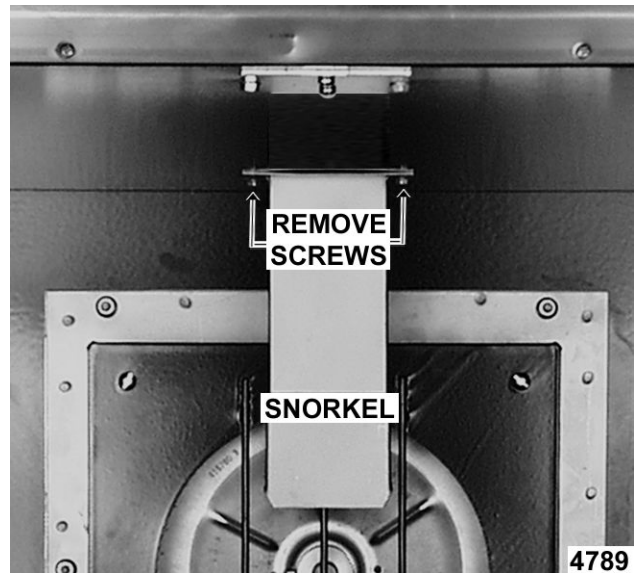

Fig. 30

7. Remove blower baffle screws (2, Fig. 31) if applicable.

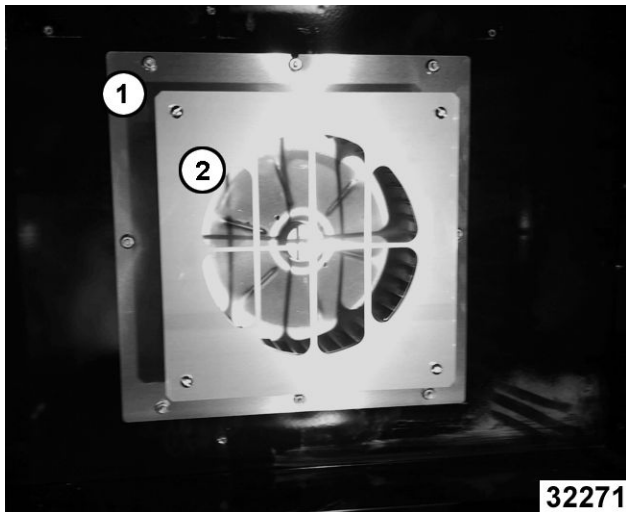

Fig. 31

8. Remove motor mounting plate nuts (1, Fig. 31).
9. Place a piece of cardboard on bottom of oven cavity to protect its surface from any damage during motor assembly removal.
10. Pull motor assembly into oven cavity and place on cardboard.
11. Remove motor mounting bolts and washers and lift motor off mounting plate.

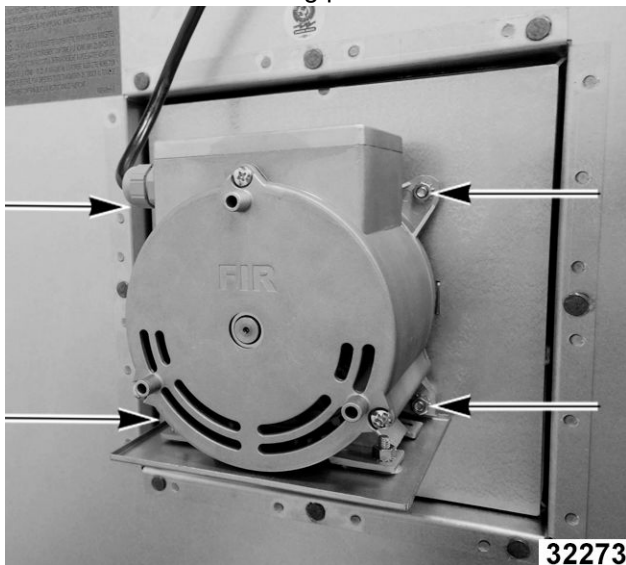

Fig. 32

NOTE: Motor graphics are shown with motor installed.

12. Remove drip pan from motor and install onto replacement motor.

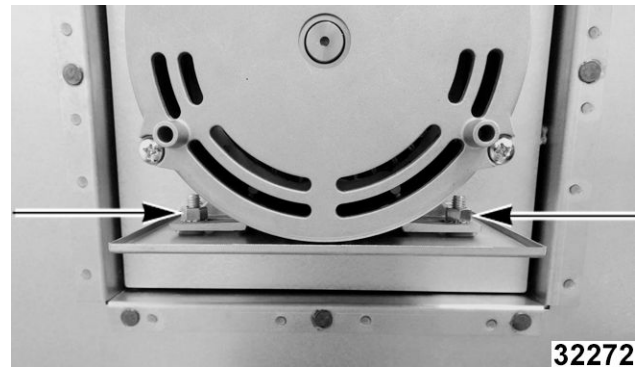

Fig. 33

13. Reverse procedure to install.
14. Verify operation.

OVEN DOORS AND BEARINGS Ending at Serial Number 481907145



WARNING

Disconnect the electrical power to the machine and follow lockout / tagout procedures.

1. Remove the top front cover and bottom front cover as outlined under Covers and Panels.
2. Remove the door switch lever.

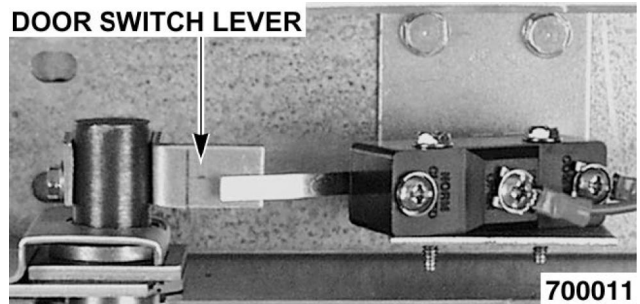

Fig. 34

3. Remove the lower door seal strip to expose the mounting screws of the door assembly.
4. Remove the two lower sill bolts by the lower door shaft and the four countersunk screws from the lower sill.

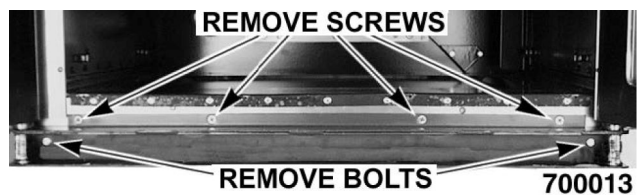

Fig. 35

- A. The door assembly is heavy and will drop down once the last screw is removed. If removing the door assembly without assistance, the ignition cable, flame sense lead and gas manifold should also be removed to avoid damage to these components.
- 5. Tilt the top of the door slightly forward and lift the door up until the bottom of the door shaft clears the opening in the sill.
- 6. Lay the door flat to prevent damage.
- 7. The top and bottom bearings are now accessible for inspection and/or replacement if needed.
 - A. If bearings are OK, proceed to step 8.
 - B. If replacing the top bearing, remove the top bearing retainer and top bearing.

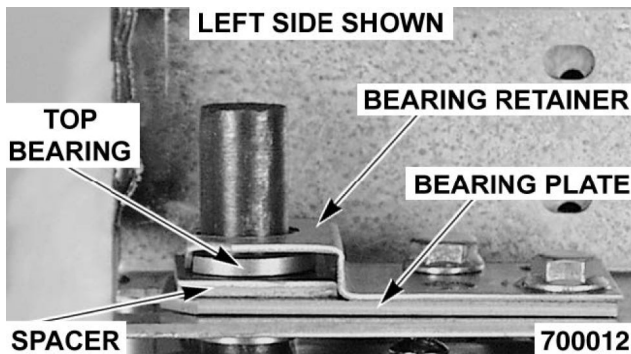

Fig. 36

- C. If replacing the bottom bearing, remove it from the door shaft or the lower sill opening.
- 8. Reverse procedure to install door assembly and check for proper operation as outlined under the Door Adjustment and Door Switch Adjustment section in Procedures and Adjustments.

OVEN DOORS (INDEPENDENT DOORS) Starting at Serial Number 481907146



WARNING

Disconnect the electrical power to the machine and follow lockout / tagout procedures.

1. Remove TOP FRONT COVER.
2. If servicing right side door, remove door switch lever (1, Fig. 37).

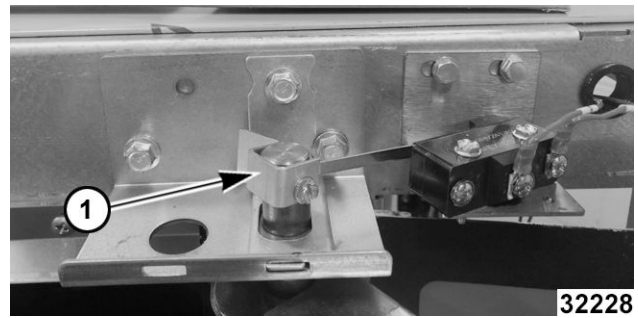

Fig. 37

3. While supporting door, remove hex bolts holding upper bearing retainer (1, Fig. 38) and upper shaft bracket (2, Fig. 38).

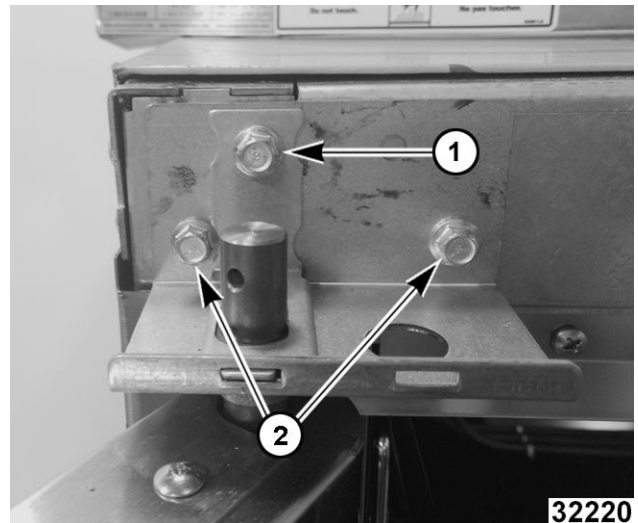

Fig. 38

4. Lift door off lower shaft bracket.

NOTICE

Lay door on flat protective surface to service.

5. Reverse procedure to install.
6. Perform door switch adjustment if servicing right side door.

ROLLER LATCH ASSEMBLY (INDEPENDENT DOORS)

NOTE: For units with serial number starting with 48 made after 8/12/07 and serial number starting with 54 made after 8/26/07.



WARNING

Disconnect the electrical power to the machine and follow lockout / tagout procedures.

1. Remove the screws that attach roller latch assembly to door.
2. Reverse procedure to install.

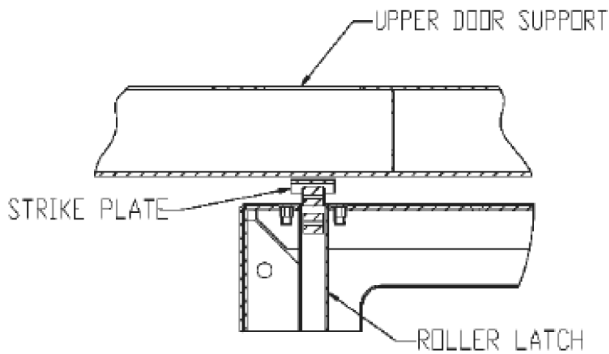

Fig. 39

DOOR CATCH ROLLER ASSEMBLY (INDEPENDENT DOORS)

NOTE: For units with serial number starting with 48 made before 8/13/07 and serial number starting with 54 made before 8/27/07.



WARNING

Disconnect the electrical power to the machine and follow lockout / tagout procedures.

1. Remove the top front cover as outlined under COVERS AND PANELS.
2. Remove the nuts and bolts that secure the door catch assembly.

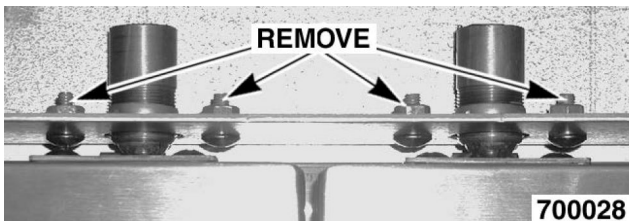

Fig. 40

3. Reverse the procedure to install.
4. Adjust the roller catch as outlined under the Door Catch Adjustment in Service Procedures and Adjustments.

DOOR WINDOW



WARNING

Disconnect the electrical power to the machine and follow lockout / tagout procedures.

1. Remove the screws at the top and bottom of the door.

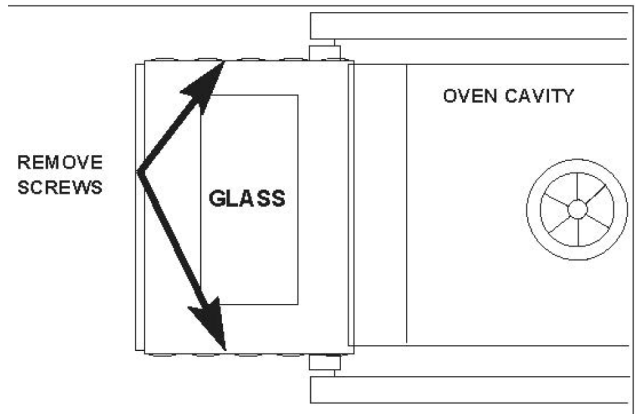

PL-56052

Fig. 41

2. Remove the door handle, then remove the outer door panel.
3. Lift out the inner door panel window assembly.
4. Remove the door seal from the inside of the left door only.
5. Remove the screws securing the window tabs to the door bracket and lift the window assembly out from the door frame.

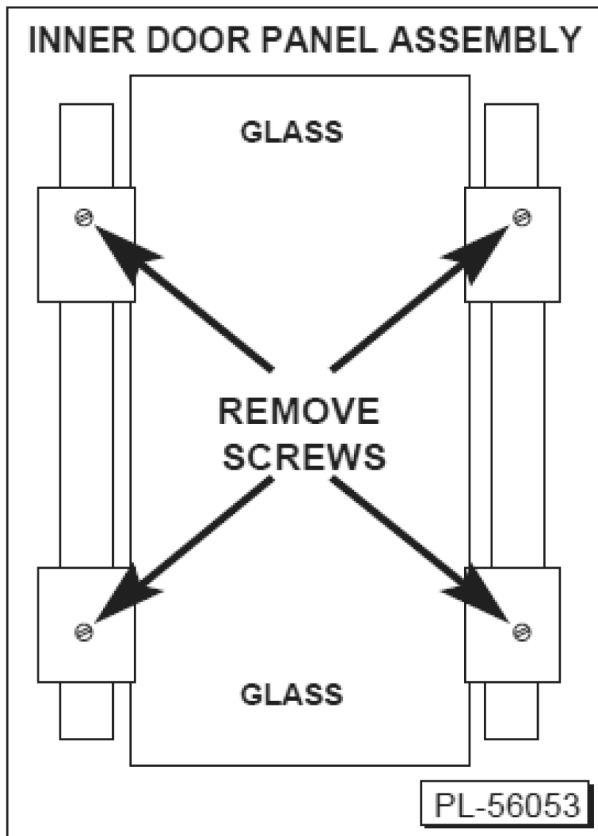

Fig. 42

- Reverse procedure to install the replacement window.

INTERIOR LIGHTS (Rear Mounted, Round)



WARNING

Disconnect the electrical power to the machine and follow lockout / tagout procedures.

Lamp

- Remove racks.
- Unscrew glass lens for the light being replaced then unscrew bulb.

NOTE: Use a cloth when handling bulb so you do not leave fingerprints on bulb.

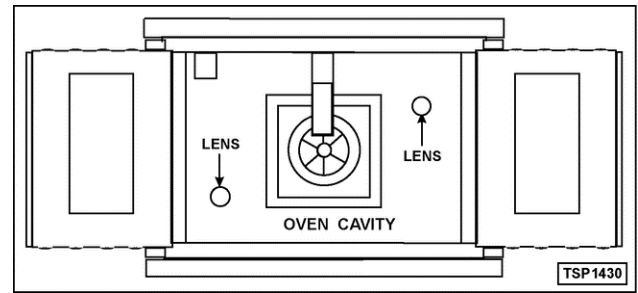

Fig. 43

- Replace bulb then reverse procedure to install.



WARNING

Disconnect the electrical power to the machine and follow lockout / tagout procedures.

Lamp Assembly

- Remove lens and bulb.
- Remove springs from retaining tabs (2 places) on the socket.

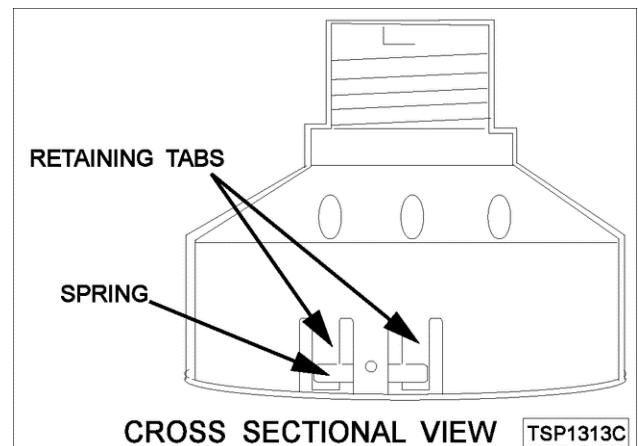

Fig. 44

- Depress retaining tabs and pull socket out from the oven, far enough to disconnect lead wires.
- Remove socket from the oven.
- Attach lead wires to the replacement socket.
- Insert socket into the hole in oven and push until socket is held in place by retaining tabs.
- Install light bulb and lens.
- Check for proper operation.

INTERIOR LIGHTS (Side Mounted, Square)

Bulb Replacement



WARNING

Disconnect the electrical power to the machine and follow lockout / tagout procedures.

1. Remove racks and right-side hand rack guide.
2. Pull lamp cover off.
3. Grasp lamp using a clean cloth and remove from lamp assembly.

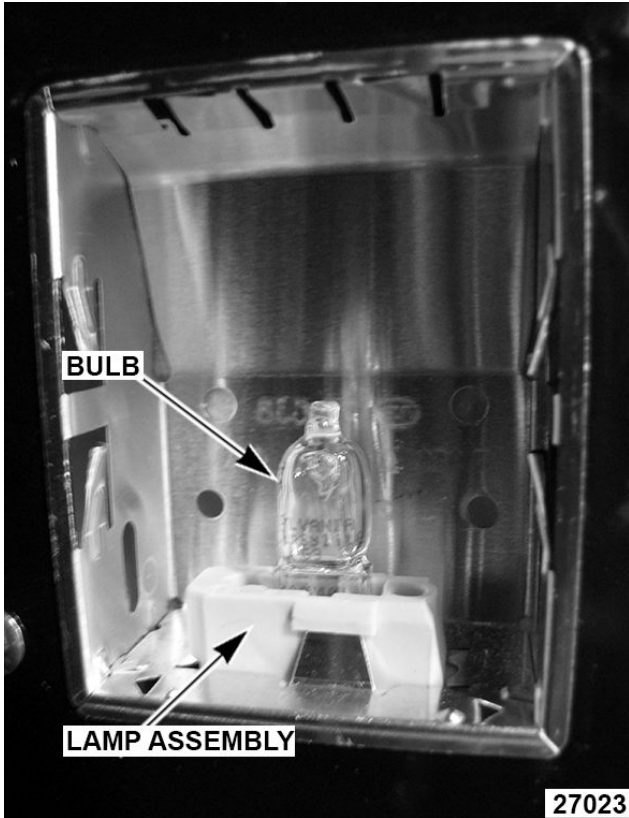

Fig. 45

4. Reverse procedure to install new bulb.

NOTE: Verify gasket (1, Fig. 46) is flat on lamp cover and not damaged.

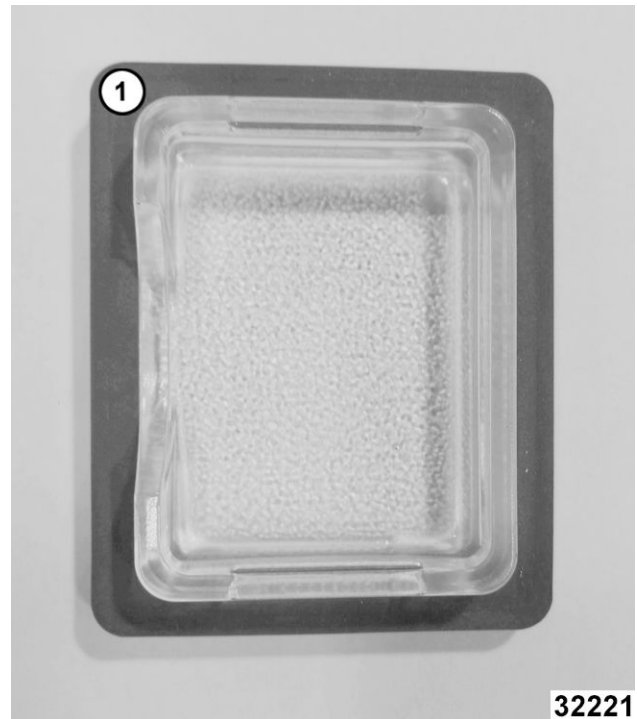

Fig. 46

Lamp Assembly Replacement



WARNING

Disconnect the electrical power to the machine and follow lockout / tagout procedures.

1. Remove racks.
2. Remove BULB if reusing.
3. Lift right side rack guide off oven cavity.
4. Pull lamp cover off from the top or bottom.
5. Insert narrow blade screwdriver into tab and bend out to release. Repeat with second tab.

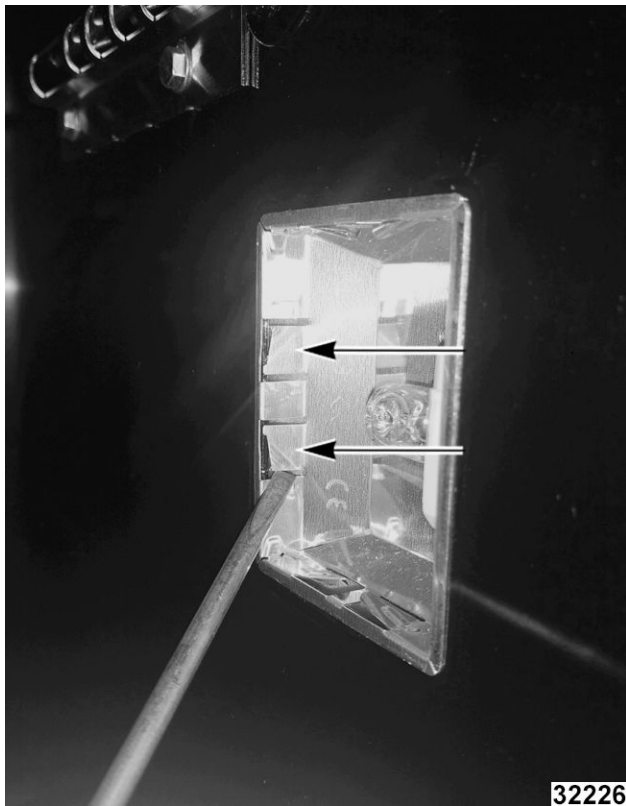

Fig. 47

6. Pull lamp housing out of oven cavity.
7. Disconnect wires.

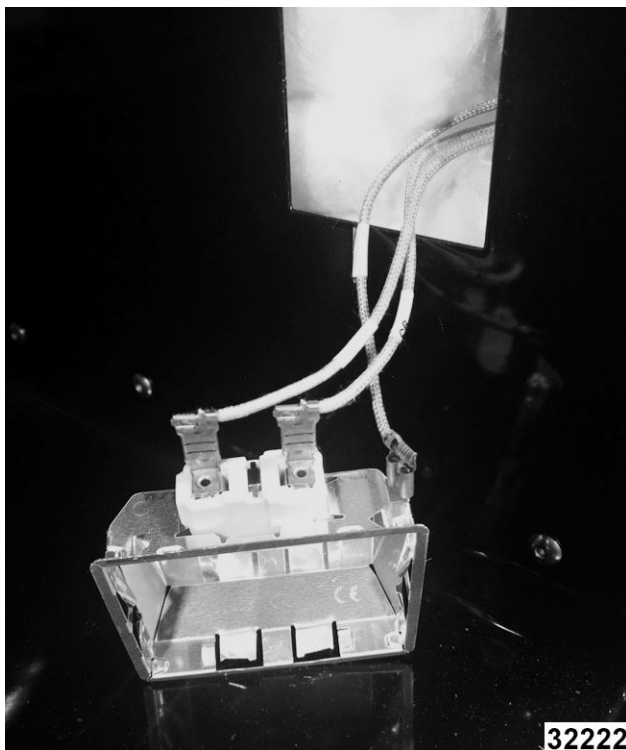

Fig. 48

8. Reverse procedure to install.

NOTE: Verify gasket (1, Fig. 49) is flat on lamp cover and not damaged.

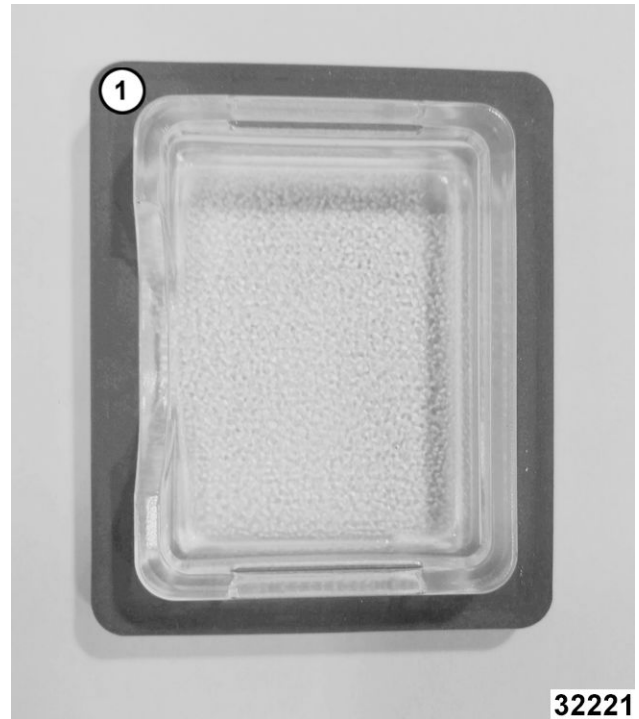

Fig. 49

DOOR SWITCH



WARNING

Disconnect the electrical power to the machine and follow lockout / tagout procedures.

1. Remove the top front cover as outlined under Covers and Panel.
2. Disconnect the lead wires to the door switch.

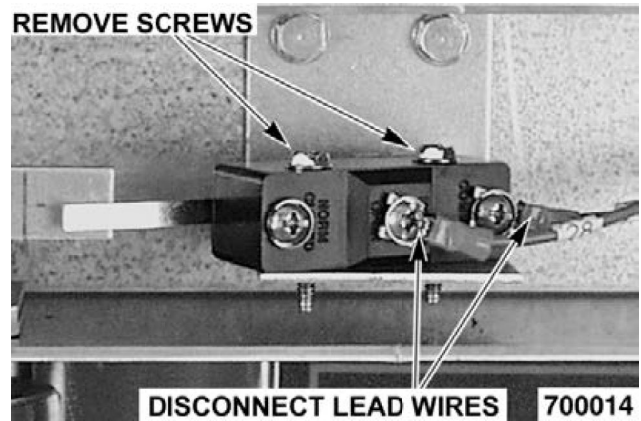

Fig. 50

3. Remove the switch.

- Reverse procedure to install the replacement switch and check for proper adjustment as outlined in Door Switch under Service Procedures and Adjustments.

HIGH LIMIT THERMOSTAT



⚠ WARNING

Disconnect the electrical power to the machine and follow lockout / tagout procedures.

- Remove the top four racks from the oven.
- Remove the high limit thermostat cover/ mounting plate. It is located at the top of the oven cavity.

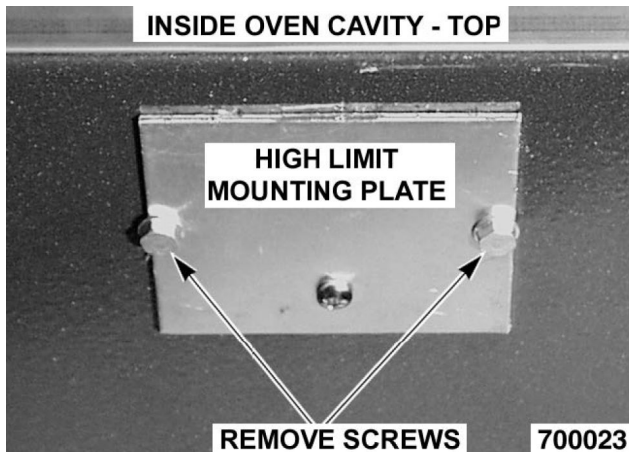

Fig. 51

- Disconnect the lead wires from the high limit thermostat. Remove the high limit thermostat from the cover mounting plate.

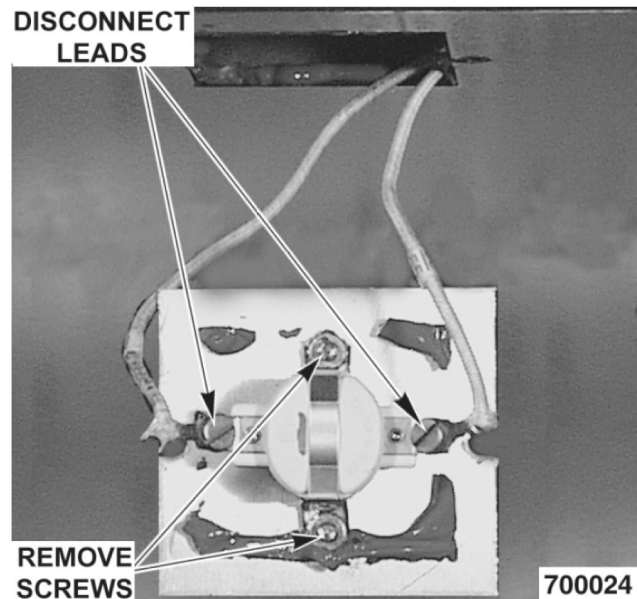

Fig. 52

- Remove the old RTV silicone from the cover and mating surfaces inside the oven cavity, and apply new RTV silicone before installing.
- Reverse procedure to install.

COOLING FAN



⚠ WARNING

Disconnect the electrical power to the machine and follow lockout / tagout procedures.

- Remove the right side panel as outlined under Covers and Panels.
- Disconnect the lead wires to the fan motor by removing the wire nuts.
- Remove the screws securing the air deflector to the fan, then loosen the tab screw holding the fan to the component panel. Rotate the tab so that the fan will clear. Remove the fan.

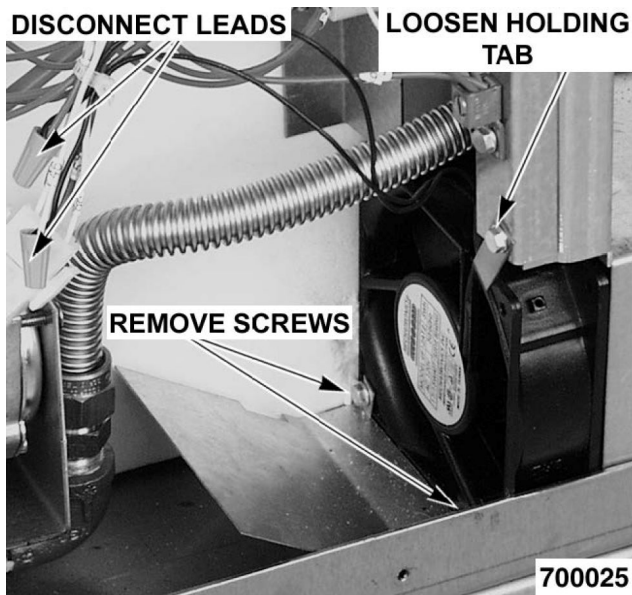

Fig. 53

4. Reverse the procedure to install the replacement fan and check for proper operation.

Fan Installation Tips

- The fan must be installed so air is pulled from the rear of the oven and blown into the control area. The arrow on the fan body indicates airflow direction and should be pointing toward the controls.
- Ensure the fan is seated squarely against the air tube and the oven bottom.
- The air deflector should be angled upward at approximately 30 degrees to properly direct the airflow.

SERVICE PROCEDURES AND ADJUSTMENTS

SOLID STATE TEMPERATURE CONTROLLER TEST (SG4D/SG6D)

⚠ WARNING

Certain procedures in this section require electrical test or measurements while power is applied to the machine. Exercise extreme caution at all times. If test points are not easily accessible, discern power, attach test equipment and reapply power to test.

Test Steps

1. Remove the right side panel as outlined under Cover and Panels in Removal and Replacement of Parts.
2. Place a thermocouple in the geometric center of the oven cavity. Oven temperature must be below 450°F.
3. Set the temperature control to the maximum setting.
4. Set the power control to 100%.
5. Check machine data plate for correct voltage to oven. Refer to diagram below for proper terminal locations and voltages before checking temperature controller. Use the correct terminals for the corresponding voltage.
6. Turn the ON-OFF-OVEN-COOL switch to ON.

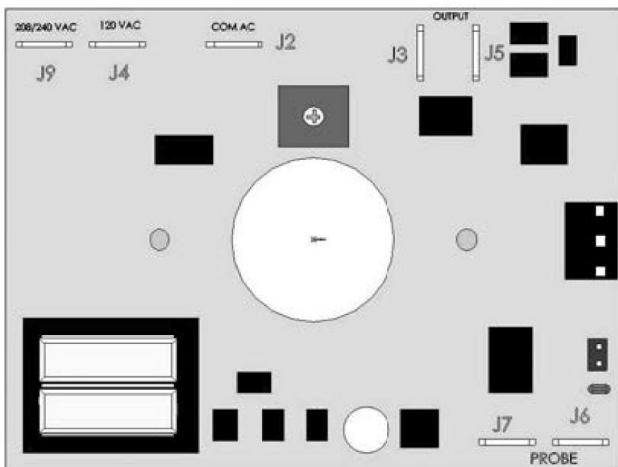

Fig. 54

7. Check for voltage across terminals J2 and J4 (120 Volt) or J2 and J9 (208/240 Volt) for power to the control.
 - A. If correct, proceed to step 8.

8. Check for voltage to the switching output.
 - A. For 120 VAC controls, check across terminals J3 and J4 for input voltage and between J4 and J5 for output voltage from the internal switching device.
 - B. For 208/240 VAC controls, check across terminals J3 and J9 for input voltage and between J9 and J5 for output voltage from the internal switching device.
 - 1) If input voltage is correct, proceed to step 9. If input voltage is not present, the problem is not in the controller (See Troubleshooting).
 - 2) If output voltage is correct, proceed to step 9. If output voltage is not correct, check temperature probe, as outlined under Temperature Probe Test (SG4D/SG6D).
 - C. If the probe connected to J6 and J7 is either shorted or opened, the red LED located just above J6 (to the left of J6 when mounted) will flash. With the probe connected and the LED not flashing, slowly turn the Temperature set knob until the pointer passes through the mid point of rotation. At the mid point of rotation, the red LED will come on. If the control is set and left at the mid point, the LED will stay on. With the LED on at mid point, you have tested the entire front end of the control circuit as well as the probe and verified that the control is functioning normally.
9. Set temperature control to minimum setting. Oven temperature must be above 300°F.
10. Check for zero volts (0.00 Volts) across terminals J4 and J5 (120 Volt) or J9 and J5 (208/240 Volt) for no output from the internal switching device.
 - A. If correct, temperature control is functioning properly.
 - B. If incorrect, check temperature probe as outlined under Temperature Probe Test (SG4D/SG6D).

- 1) If temperature probe is functioning properly and the temperature controller failed the test in 8c above, replace the temperature control and check for calibration as outlined under Solid State Temperature Controller Calibration (SG4D/SG6D).

SOLID STATE TEMPERATURE CONTROL CALIBRATION (SG4D/SG6D)

⚠ WARNING

Certain procedures in this section require electrical test or measurements while power is applied to the machine. Exercise extreme caution at all times. If test points are not easily accessible, discern power, attach test equipment and reapply power to test.

Before attempting any calibration, see Section 8C of SOLID STATE TEMPERATURE CONTROLLER TEST (SG4D/SG6D) on previous page.

Calibration Steps

1. Place a thermocouple in the geometric center of the oven cavity.
2. Set the ON/OFF/OVEN COOL switch to ON.
3. Set the temperature controller dial to 350°F. Set the power control to 100% (10).
4. Allow the oven temperature to stabilize (minimum three heating cycles).
5. Record the temperature at which the Heat lamp comes ON (heating starts) and goes OFF (heating stops). This is the control differential. Heat lamp OFF temp - Heat lamp ON temp = Control Differential.
6. The nominal control differential should be less than 20°F.
 - A. If the control differential is less than 20°F, the temperature control circuit is functioning properly. Proceed to step 7.
 - B. If the control differential is more than 20°F, check the temperature probe as outlined under Temperature Probe Test (SG4D/SG6D).
 - C. If the control differential is more than 20°F and the probe passes its' test parameters, then temperature controller is malfunctioning. Install a new temperature controller and run calibration steps again.
7. Calculate the average oven temperature by adding the actual minimum temperature to the actual maximum temperature and dividing by 2.

EXAMPLE:

Oven set to 350°F.

Actual minimum oven temperature = 335°F

Control cuts on at 334°F

Actual maximum oven temperature = 347°F

Control cuts off at 340°F

$$335 + 347 = 682$$

$$682 / 2 = 341 \text{ (the control is } 9^\circ\text{F out of calibration)}$$

$$340 - 334 = 6^\circ\text{F Control Differential}$$

$$347 - 335 = 12^\circ\text{F Oven Temperature Differential}$$
 - A. If the average oven temperature is within +/- 5°F from the dial setting, no calibration is necessary.
 - B. If the average oven temperature is not within +/- 5°F, calibration is recommended.
8. Loosen the set screw on the temperature controller and carefully remove the knob from the shaft, without rotating the shaft. This will expose the calibration adjustment control access hole in the front panel.
9. Monitor the internal oven temperature and determine at what temperature the control should cut on to give you the required minimum temperature (Example: $350 - 341 = 9$; $334 + 9 = 341$. 341°F is the temperature at which you would wish the controller to cut on).
10. After allowing the oven to operate through several cycles (minimum 3 cycles), monitor the temperature as it falls to the desired "cuts on" point. Using a small screw driver, adjust the calibration adjustment until the controller cuts on at the desired "cuts on" temperature.
11. The calibration control is adjusted clockwise in order to increase the set temperature and counter clockwise to decrease the set temperature.
12. The controller has only +/- 25°F of adjustment. 1/4 turn of the calibration adjustment represents approximately 20°F shift in calibration.

TEMPERATURE PROBE TEST (SG4D/SG6D)

⚠ WARNING

Certain procedures in this section require electrical test or measurements while power is applied to the machine. Exercise extreme caution at all times. If test points are not easily accessible, discern power, attach test equipment and reapply power to test.



⚠ WARNING

Disconnect the electrical power to the machine and follow lockout / tagout procedures.

Test Steps

1. Remove the right side panel as outlined under Cover and Panels in Removal and Replacement of Parts.
2. Place a shielded thermocouple in the geometric center of the oven cavity and determine the temperature in the oven cavity.
3. Remove the probe lead wires from the solid state temperature controller.
4. Test the probe with an ohmmeter.
 - A. If the measured resistance values are inside the given tolerance, then the probe is functioning properly.
 - B. If the measured resistance values are outside the given tolerance, then replace the probe and make sure wires are secured to the terminals of the temperature controller. Recheck the temperature by performing step 2.
 - 1) Check the oven for proper operation.
5. Reverse Procedure to install.

TEMP (°F)	OHMS*
77	90,000
240	4,077
260	3,016
280	2,266
300	1,726
320	1,332
340	1,041
360	822
380	656
400	529
425	424
450	334
475	266
(*) Resistance in ohms ± 10%	

COMPUTER CONTROLLER (SG4C/SG6C)

⚠ WARNING

Certain procedures in this section require electrical test or measurements while power is applied to the machine. Exercise extreme caution at all times. If test points are not easily accessible, discern power, attach test equipment and reapply power to test.

Operation

Refer to the Installation & Operation Manual for specific operating instructions.

Setup Mode

Use the setup mode to verify that the control is configured to the factory settings which result in the proper operation of the oven. If the CAL1 parameter is other than zero, see Computer Control Calibration (SG4C/SG6C).

CAUTION: Changing the C_F, InP1, rL1 and rH1 parameters will default all menus.

- Use this key sequence to access the setup mode: UP arrow, Rack 1, Temperature, Temperature, DOWN arrow, Rack 1.



Fig. 55

- Once in the setup mode the display will alternate between the parameter and programmed data.
 - To change data to the factory setting, use the arrow keys.
 - To select the next parameter, press the Rack 1 key.
 - After the last parameter and data are viewed, press the Rack 1 key to exit the setup mode and return to operations mode. The current set point temperature will be displayed.
 - If there are no key activations after 1 minute, the control will return to operation mode.
- Listed are the parameters and data in the setup mode.

MENU	ALTERNATING ON DISPLAY	
	PARAMETER	DATA
Celsius_Fahrenheit	C_F	F

Guard Band	gb	4000
Temperature Compensaion	tcnP	OFF
Input Type 1	InP1	J
Range Low 1	rL1	75
Range High 1	rH1	500
Hysteresis	HYS1	3
Calibration Offset	CAL1	0
Exit setup mode and return to operation mode.	Set point temperature is displayed or if calling for heat, dashes (----) are displayed.	

Probe Test

If the oven is not heating or displaying the proper temperature, the temperature probe may be malfunctioning. Determine if the probe is good or causing the operational problem.

- Temporarily disconnect the existing lead wires from the computer control and connect them to a good J-type thermocouple.
- Turn the power switch to ON and set the temperature controller to 350°F.
 - If the oven reaches the set temperature and cycles with the temporary thermocouple, then the existing probe is malfunctioning.
- Replace the temperature probe with the correct part and check for proper operation.

Solid State Relay Test

- Remove the right side panels as outlined under Covers and Panels in Removal and Replacement of Parts.
- Turn the power switch to the ON position.
- Check for +5 VDC on input side of SSR-1 in the normal heating mode (terminals 3 & 4) and SSR-2 in the roast and hold mode.
 - If +5 VDC is present, continue to step 4.
 - If no voltage is present, computer control is not functioning properly.
- Check for 120 VAC at load side of SSR (terminals 1 & 2).
 - If no voltage is present, solid state relay is not functioning properly.
 - Replace the SSR and check for proper operation.

- B. If 120 VAC is present, component is functioning properly.
5. Reassemble oven and check for proper operation.

COMPUTER CONTROL CALIBRATION (SG4C/SG6C)

⚠ WARNING

Certain procedures in this section require electrical test or measurements while power is applied to the machine. Exercise extreme caution at all times. If test points are not easily accessible, discern power, attach test equipment and reapply power to test.

Calibration Steps

1. Place a thermocouple in the geometric center of the oven cavity.
2. Set the ON-OFF-COOL DOWN switch to ON.
 - A. If the set point temperature is 350°F, proceed to step 4.
 - B. If the set point temperature is other than 350°F, proceed to step 3 to change the temperature.
3. Press the set key then temperature key to enter the temperature set mode.
 - A. The display will alternate between the term StPt (set point) and the current oven temperature setting.
 - B. Press the UP or DOWN arrows to make the proper selection.
 - C. Press the set key again to save the change, then exit the temperature set mode.
4. Allow the oven temperature to stabilize (normally three cycles).
5. Compare the controls set point temperature to the thermocouple meter reading when the heat light goes out.
 - A. A temperature variance more than 5°F indicates an adjustment is needed.
 - 1) To make the adjustment, proceed to step 6.
 - 2) If temperature variances is less than 5°F, then the computer control is functioning properly.
6. Enter the setup mode as outline in Setup Mode under Computer Control (SG4C/SG6C).
 - A. Advance through the menu until CAL1 (calibration offset) appears.
 - 1) If the thermocouple reading is higher than set point temperature, press the down arrow key and enter a negative offset value that is equal to the number of degrees above the 5°F tolerance.
 - 2) If the thermocouple reading is lower than set point temperature, press the UP arrow and enter a positive offset value that is equal to the number of degrees below the 5°F tolerance.
 - 3) Exit the setup mode.
7. Allow the oven to cycle at least two times between adjustments.
 - A. If the temperature variance still differs more than 5°F from the set point, verify the correct calibration offset value was entered and retained.
 - 1) Adjust the calibration offset value as outlined in step 6, until the cycling temperature is within tolerance.
 - B. If the above adjustment cannot be obtained, replace the computer control and check for proper operation.

GAS PRESSURE ADJUSTMENT

⚠ WARNING

Certain procedures in this section require electrical test or measurements while power is applied to the machine. Exercise extreme caution at all times. If test points are not easily accessible, discern power, attach test equipment and reapply power to test.



⚠ WARNING

Disconnect the electrical power to the machine and follow lockout / tagout procedures.

Accurate gas pressure adjustments can only be made with the gas on and the burner lit. If the incoming line pressure to the valve is less than the minimum stated, then the manifold pressure cannot be set correctly.

1. Turn gas supply off at manual shutoff valve.
2. Remove the right side panel as outlined under Covers and Panels in Removal and Replacement of Parts.

- Remove the plug from the manifold pressure port.

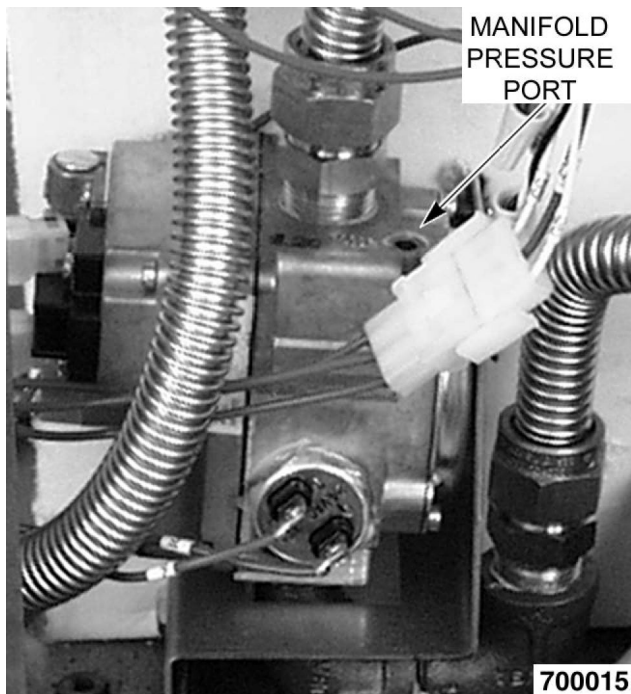

Fig. 56

- Install hose barb adapter and attach manometer tube.

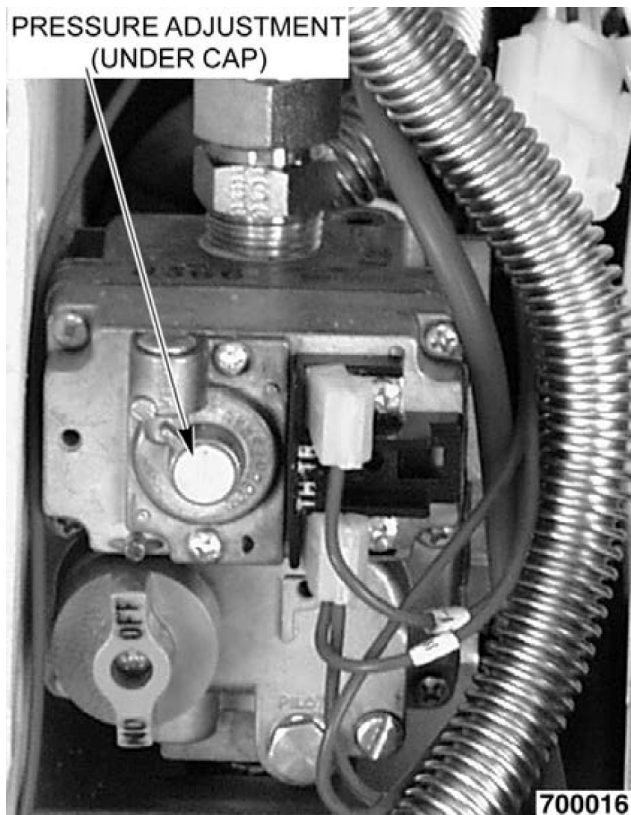

Fig. 57

- Remove adjustment screw cap from the gas valve and turn gas supply to the oven back on.

⚠ WARNING

The following steps require power to be applied to the unit during test. Use extreme caution at all times.

- Plug the unit in and turn the power switch ON.
- Set the temperature controller to its highest setting and allow burner to ignite. The burner must be lit during test and adjustment.
- Turn the set screw to obtain the proper gas pressure (clockwise = pressure increase; counterclockwise = pressure decrease).

GAS TYPE	PRESSURE READINGS (IN W.C.)			
	MANIFOLD	LINE		
		RECOMMENDED	MIN	MAX
Nat.	3.5	7.0	5.0	14
Prop.	10	11.0	11.0	

NOTE: Nat. = Natural Gas; Prop. = Propane

VERIFICATION OF SPARK AT IGNITOR

⚠ WARNING

Certain procedures in this section require electrical test or measurements while power is applied to the machine. Exercise extreme caution at all times. If test points are not easily accessible, discern power, attach test equipment and reapply power to test.



⚠ WARNING

Disconnect the electrical power to the machine and follow lockout / tagout procedures.

⚠ WARNING

Shut off the gas before servicing the oven.

- Remove the bottom front cover as outlined under Covers and Panels in Removal and Replacement of Parts.
- Disconnect the high voltage ignition cable from the spark igniter.

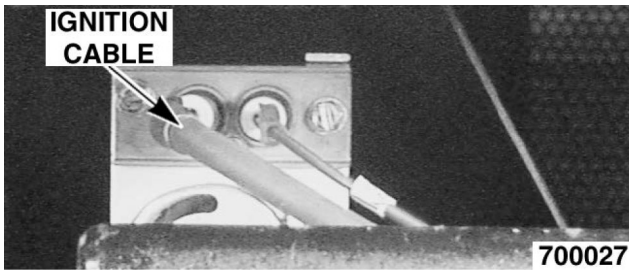

Fig. 58

⚠ WARNING

Do not hold the wire with your hands for this test. The manual gas valve must be closed.

3. Clamp the ignition cable in a manner that will position the end of the cable 3/16" from the oven frame (bare metal surface). It is critical that the cable be held 3/16" away from the surface of the oven frame or sparking may not occur even though the sparking circuit is functioning properly.

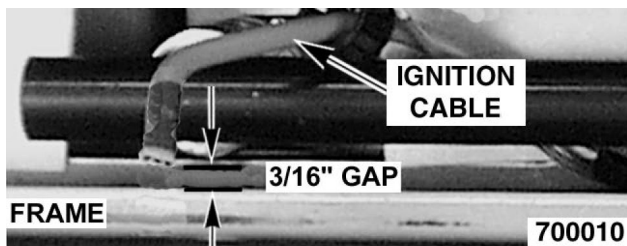

Fig. 59

⚠ WARNING

The following steps require power to be applied to the unit during the test. Use extreme caution at all times.

4. Plug the oven in and set the temperature controller to the maximum setting.
5. Turn the power switch ON.
6. Sparking should occur after a 4 second delay and continue for 7 seconds. The cycle will repeat twice after a 15 second purge time. Arcing from the ignition cable to the oven frame should be observed.

DOOR SWITCH ADJUSTMENT

⚠ WARNING

Certain procedures in this section require electrical test or measurements while power is applied to the machine. Exercise extreme caution at all times. If test points are not easily accessible, discern power, attach test equipment and reapply power to test.

⚠ WARNING

Disconnect the electrical power to the machine and follow lockout / tagout procedures.

1. Remove the top front cover as outlined under Covers and panels in Removal and Replacement of Parts.
2. Door operation:
 - A. The switch actuator is engaged by the switch lever when the right door is between 1" and 1 1/2" from being closed.
3. If adjustment is necessary, bend the switch actuator to obtain the proper setting.

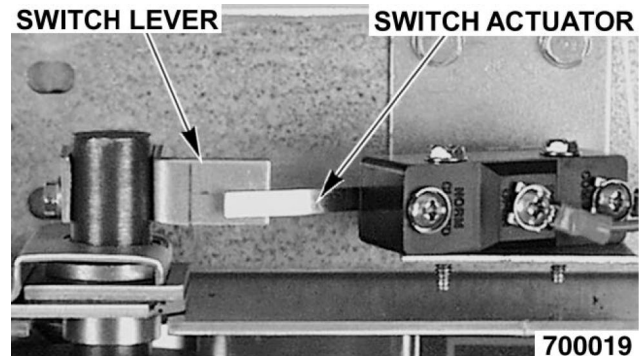

Fig. 60

4. Install the top front cover.
5. Apply power to the oven and check for proper operation.

FLAME SENSE CURRENT TEST



⚠ WARNING

Disconnect the electrical power to the machine and follow lockout / tagout procedures.

1. Remove screws securing right side of the top front cover, bottom front cover and control panel.
2. Remove right side panel mounting screws.

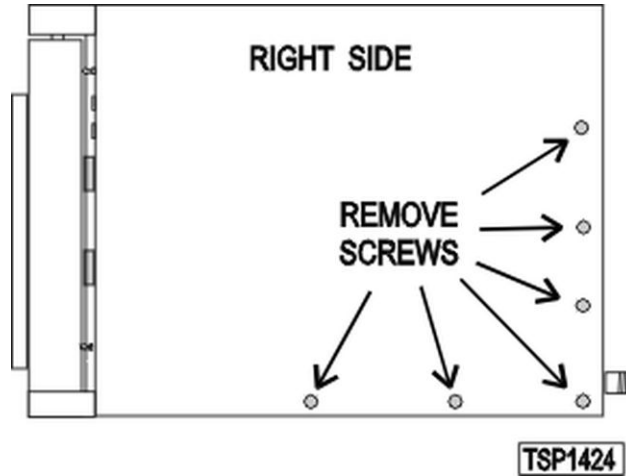

Fig. 61

3. Pull right side panel out from the bottom then down to remove.
4. Remove top screw and loosen bottom screw securing the ignition control module mounting bracket.

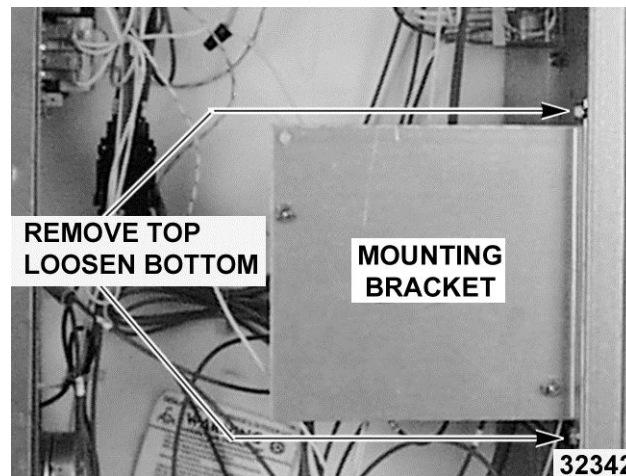

Fig. 62

5. Position bracket horizontally by pulling forward 90 degrees, with ignition module facing up for accessibility.
6. Set VOM meter to read Micro Amps.
7. Place red (Positive) lead on FC+ and black (Negative) lead on FC- terminals on ignition module to test. Repeat on other Micro Amps.

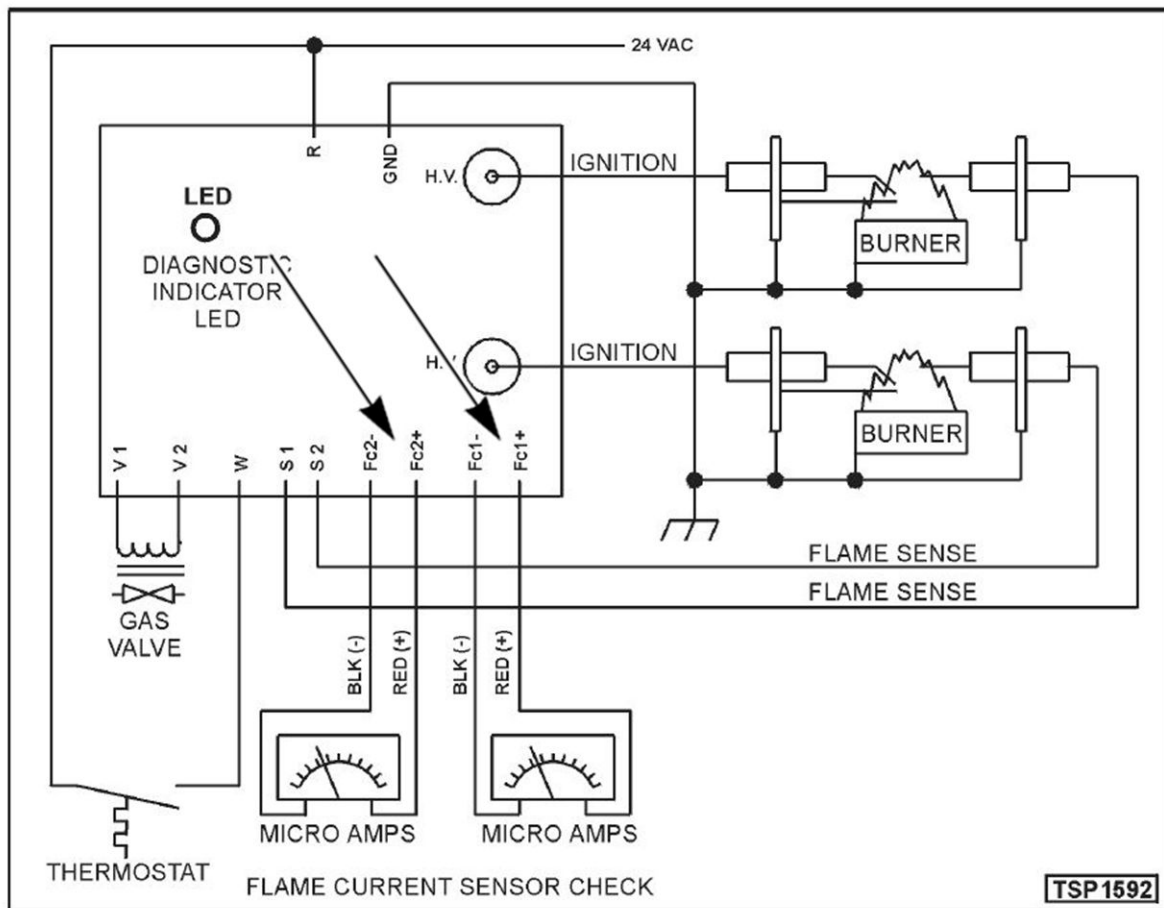

Fig. 63

8. Set the oven to call for heat and measure the Micro Amps reading.

NOTICE

Micro Amp reading from the flame sensor should measure a minimum of 0.7 Micro Amps to maintain burner ignition.

- If Micro Amp reading is correct and the burner does not light and maintain flame, replace ignition module.
- If Micro Amp reading is **NOT** correct, check wiring from flame sensor/igniter to the ignition module. If wiring is ok, replace flame sensor/igniter.

9. Install ignition control module mounting bracket and right panel.
10. Verify operation.

BLOWER ADJUSTMENT

⚠ WARNING

Certain procedures in this section require electrical test or measurements while power is applied to the machine. Exercise extreme caution at all times. If test points are not easily accessible, discern power, attach test equipment and reapply power to test.



⚠ WARNING

Disconnect the electrical power to the machine and follow lockout / tagout procedures.

1. Remove the blower motor and mounting assembly as outlined under Blower and Motor in Removal and Replacement of Parts.
2. Loosen the motor mounting bolts.
3. Adjust the motor position until the blower is parallel to and 1/4" inch away from the motor mounting plate. Check to see if the blower is square to the motor mounting plate at the top, bottom, left and right of the blower.
 - A. If the blower is square, then tighten motor mounting bolts and proceed to step 4.
 - B. If the blower is not square, continue adjusting until proper spacing is achieved then tighten motor mounting bolts. If necessary, place shims between motor and frame.

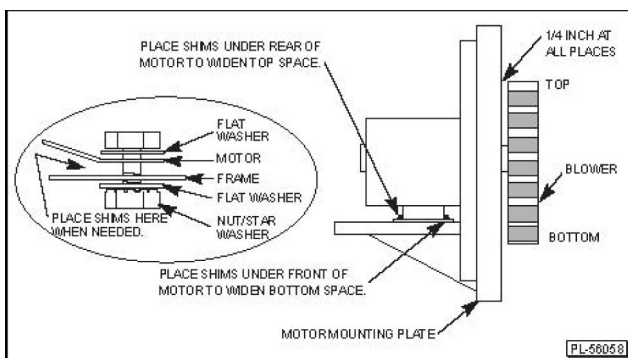

Fig. 64

4. Reverse the procedure to install. Use locktight on mounting nuts and bolts.

DOOR STRIKE ADJUSTMENT (INDEPENDENT DOORS)

⚠ WARNING

Certain procedures in this section require electrical test or measurements while power is applied to the machine. Exercise extreme caution at all times. If test points are not easily accessible, discern power, attach test equipment and reapply power to test.

NOTE: For units with serial number starting with 48 made after 8/12/07 and serial number starting with 54 made after 8/26/07.



⚠ WARNING

Disconnect the electrical power to the machine and follow lockout / tagout procedures.

1. Remove the top front cover as outlined under COVERS AND PANELS in REMOVAL AND REPLACEMENT OF PARTS.
2. Open the doors and inspect the door strike for proper shape.
 - A. Replace if bent. Do not bend strike plate.
 - B. If adjustment is necessary, loosen fasteners, close doors and insure contact between the door inner surface and upper horizontal seal. Slide door strike plate until contact with roll latch is made. Tighten strike plate fasteners.

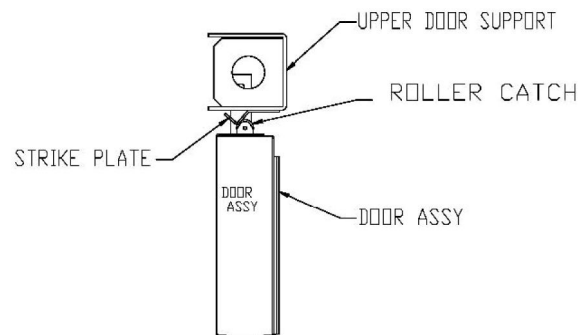

SIDE VIEW

Fig. 65

3. Open and close the doors several times while observing the roller latch and strike plate operation.

- A. Replace roller latch if malfunctioning as outlined under ROLLER LATCH ASSEMBLY (INDEPENDENT DOORS) and adjust as outlined in this procedure.
- 4. Each oven door should be open with a force of 8 to 25 pounds when pulled at the handle. The adjustments must allow the doors to remain closed during normal operation and allow opening without exertion by the user.

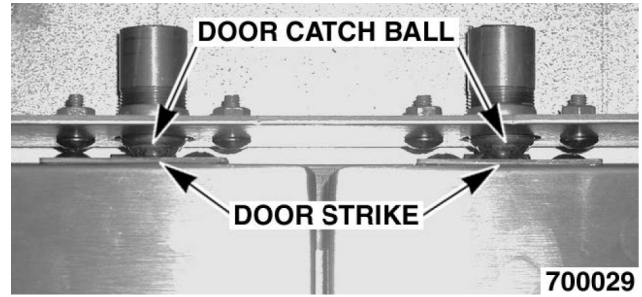

Fig. 66

DOOR CATCH ROLLER ADJUSTMENT

⚠ WARNING

Certain procedures in this section require electrical test or measurements while power is applied to the machine. Exercise extreme caution at all times. If test points are not easily accessible, discern power, attach test equipment and reapply power to test.

NOTE: For units with serial number starting with 48 made before 8/13/07 and serial number starting with 54 made before 8/27/07.

- 6. Place a standard flat screwdriver through the opening in the top channel into the slot in the cylinder of the catch assembly.

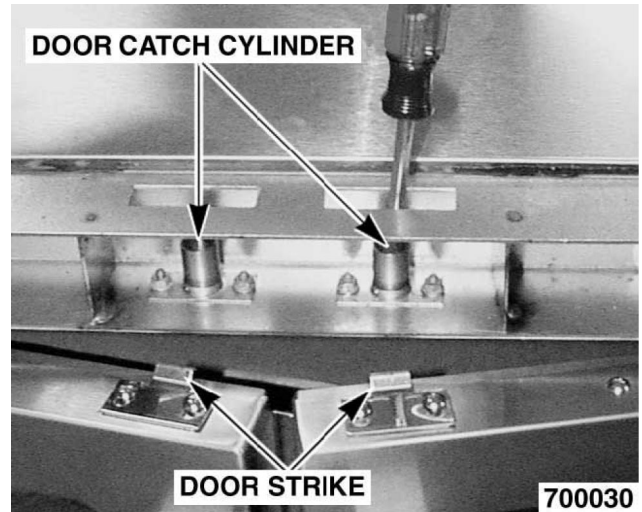

Fig. 67



⚠ WARNING

Disconnect the electrical power to the machine and follow lockout / tagout procedures.

- 1. Remove the top front cover as outlined under Cover and Panels in Removal and Replacement of Parts.
- 2. Inspect the door strike to make sure it is straight, and replace if bent.
- 3. Inspect the door catch assembly, and replace if it is damaged.
- 4. Check for proper door alignment.
 - A. Doors should be centered in the cavity opening and parallel to top and bottom of oven as outlined under Door Adjustment.
- 5. With the door in closed position, check to see that the ball of the catch is centered and touching the door strike. If not, it may be necessary to adjust and add a shim piece to the door strike.

- 7. Turn the screwdriver clockwise to increase the ball pressure or counterclockwise to decrease the pressure onto the door strike. The ball pressure should be tight enough to hold the door in place when the blower is engaged.
- 8. After the adjustment is complete, lubricate the inside of the door catch cylinder.

DOOR ADJUSTMENT



⚠ WARNING

Disconnect the electrical power to the machine and follow lockout / tagout procedures.

- 1. Check the doors to make sure they have a .125 (1/8") gap between them and that the vertical edge of the door is parallel to the vertical door seal. If the doors are not positioned in this manner, adjust the doors as described.

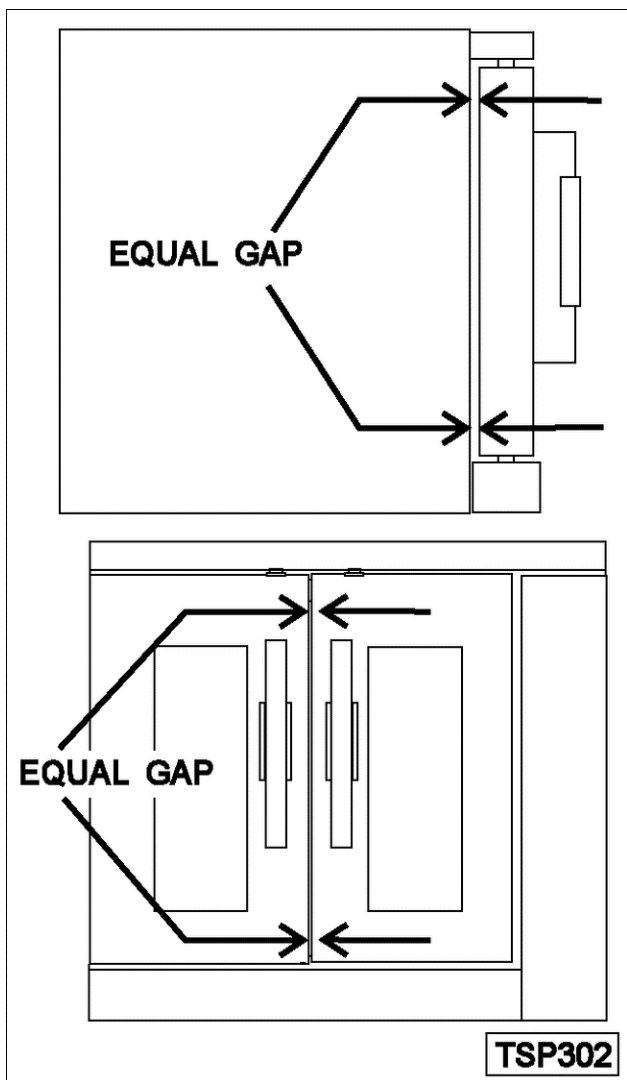

Fig. 68

2. Remove the TOP FRONT COVER.
3. Loosen the screws/bolts that secure the upper door brackets just enough to allow door movement.

Figure Shown below (Left Side) is ending at Serial Number 481907145.

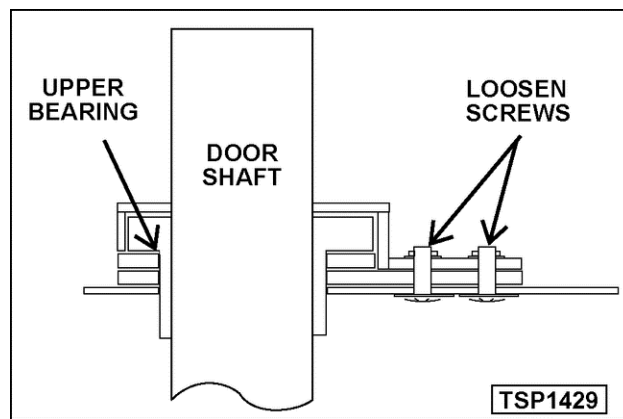

Fig. 69

Figure shown below (Left Side) is starting at Serial Number 481907146.

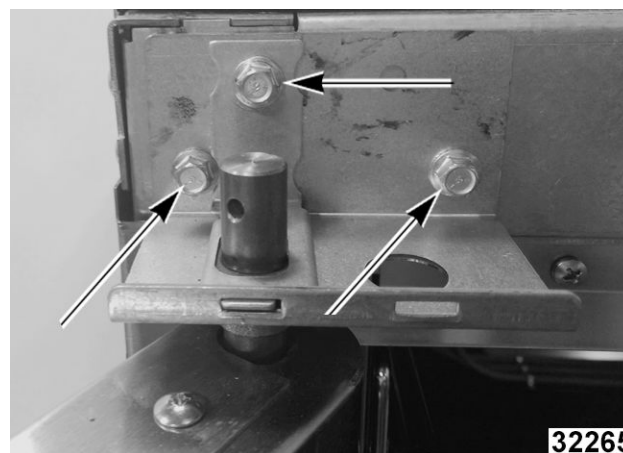

Fig. 70

4. Move the door until proper alignment is achieved then tighten the screws/bolts on the upper door bearing hardware.
5. Repeat STEP 3 and STEP 4 on the opposite door, if necessary.
6. Install TOP FRONT COVER.

ELECTRICAL OPERATION

COMPONENT DESCRIPTION

Master Switch (S1) - Determines the mode of operation; ON, OFF or OVEN COOL

Lights Switch (S2) - Controls the oven cavity lights.

Fan Speed Switch Hi/Low (S3) - Controls blower motor speed between HI and LOW settings. Available on models SG4D/SG6D.

Alarm/Buzzer - Signals the end of the normal cook cycle when cooking time expires.

Timer - Times the cooking cycle and signals the buzzer at the end of the cycle.

Door Switch - Allows the oven to operate when the doors are closed but stops the oven from operating when the doors are opened.

Blower Motor - Operates the oven cavity blower. Also, an internal centrifugal switch on the motor is utilized to allow the connection of power to the heat relay when the motor is at operating speed.

Transformer (T1) - Provides 24 VAC power to the ignition control module and heating circuit.

Motor Control Relay(s) (SG4C/SG6C) - Provides power to HI and LOW speed motor windings based on operator requirements.

Solid State Temperature Controller (SG4D/SG6D) - Monitors temperature sensor and regulates the oven cavity temperature by controlling the heat relay through the blower motor centrifugal switch contacts.

Ignition Control Module - Provide ignition spark and monitors burner(s) flame current during ignition sequence.

Ignition Electrode and Flame Sense Device - Ignites the gas and senses the presence of a flame. The flame presence generates a micro-amp flame sense current that is monitored by the ignition control module. A flame sense current of 1 micro amp (minimum and stable) is required to maintain burner ignition.

Power On Light (SG4D/SG6D) - Lit whenever the Master Switch (S1) is turned to ON or OVEN COOL mode.

Heat Light - Lit whenever temperature controller is calling for heat.

No Ignition Light (SG4C/SG6C) - Lit when power is turned ON, during ignition trial and gas purge time and when no flame is detected by flame sensor. If the oven fails to ignite after three attempts, it will remain lit until power is reset.

Temperature Probe (SG4D/SG6D) - This temperature probe is a thermistor device. A thermistor is a calibrated resistor which changes resistance with the temperature. As the temperature increases, the resistance of the thermistor decreases. The resistance of the probe is compared to the resistance of the temperature controller resistor in to control and maintain temperature.

Temperature Probe (SG4C/SG6C) - This temperature probe is a J-type thermocouple. As the temperature increases, a DC voltage is generated within this thermocouple and compared to a list of temperature values stored within the cooking computer memory to control and maintain temperature.

High Limit Thermostat - Protects the oven from temperatures above 550°F by removing power from the first valve (safety) on the dual solenoid gas valve which stops the flow of gas to the burner. Auto resets at 500°F.

Gas Valve (Dual Solenoid) - Contains two valves. The first valve is opened when the unit is turned on and the limit temperature is not exceeded. The second valve is turned by the heating system. Both valves must be open in order to get gas to the main burners.

SSR1 and SSR2 (SG4C/SG6C) - When SSR1 is energized, it connects power to the blower motor for HI fan speed operation. When SSR2 is energized, it connects power to blower motor for LOW speed operation.

Cooling Fan - Circulates cooler air from rear of oven forward to cool components in the control area.

Computer Control (SG4C/SG6C) - Monitors temperature sensor and regulates the oven cavity temperature by controlling the heat relay (R1) through the blower motor centrifugal switch contacts. Also, counts the time of the product and signals the electronic alarm at the end of the cook cycle.

Power Level Control - Selects the percent of heat input between 22% and 100%. Power level must be on for oven to work.

Plug, Socket and Components (SG4D/SG6D)

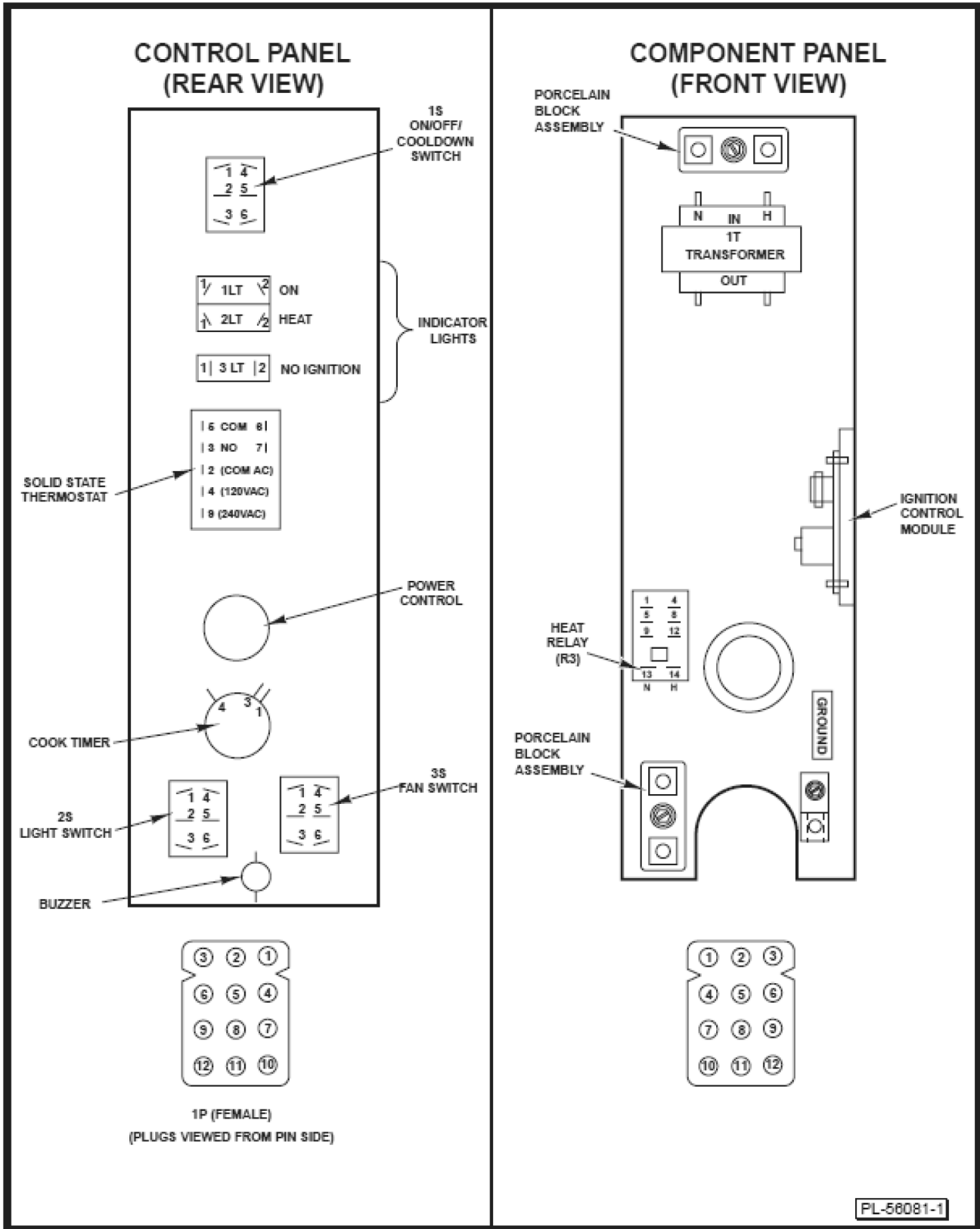

Fig. 71

Plug, Socket and Components (SG4C/SG6C)

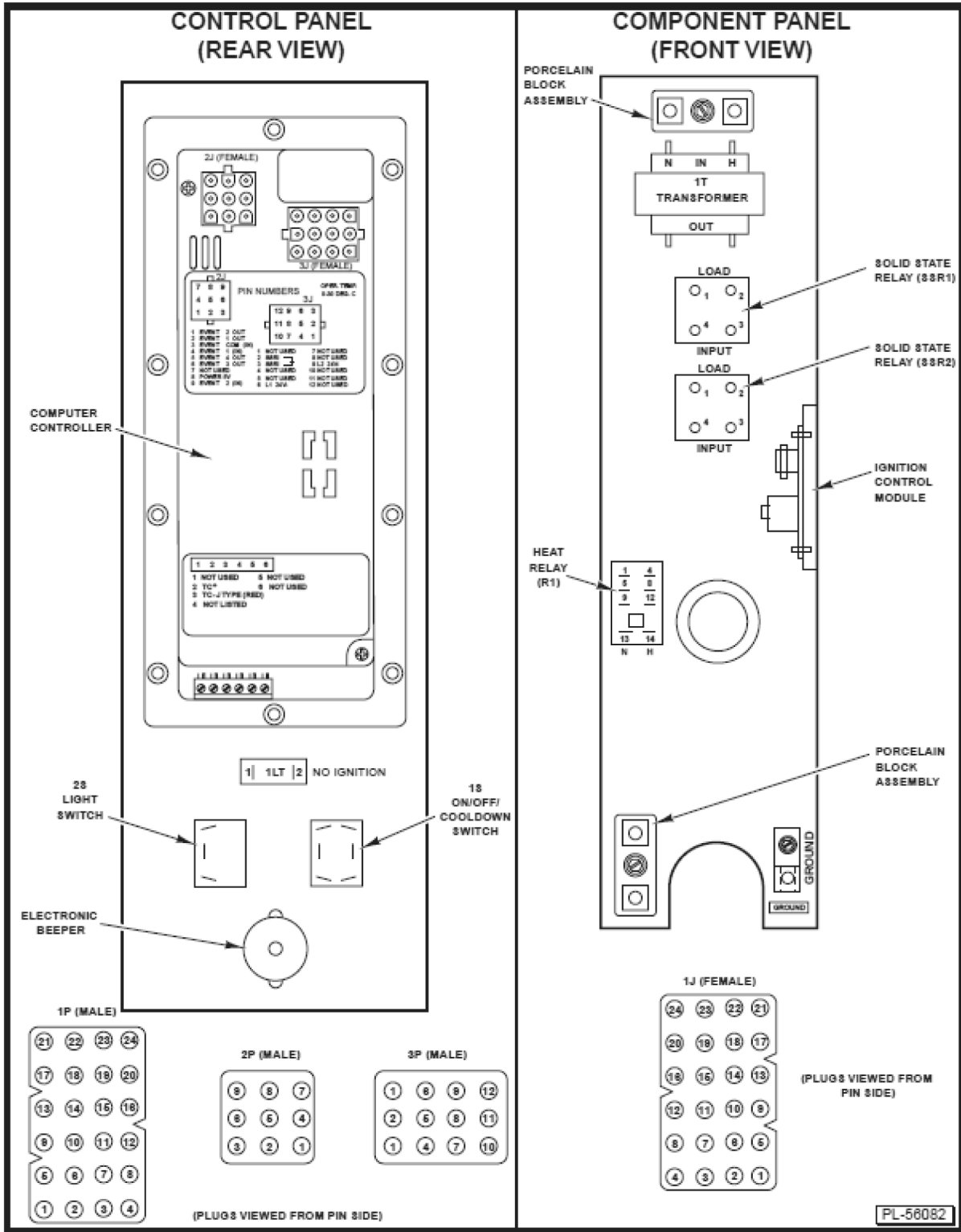
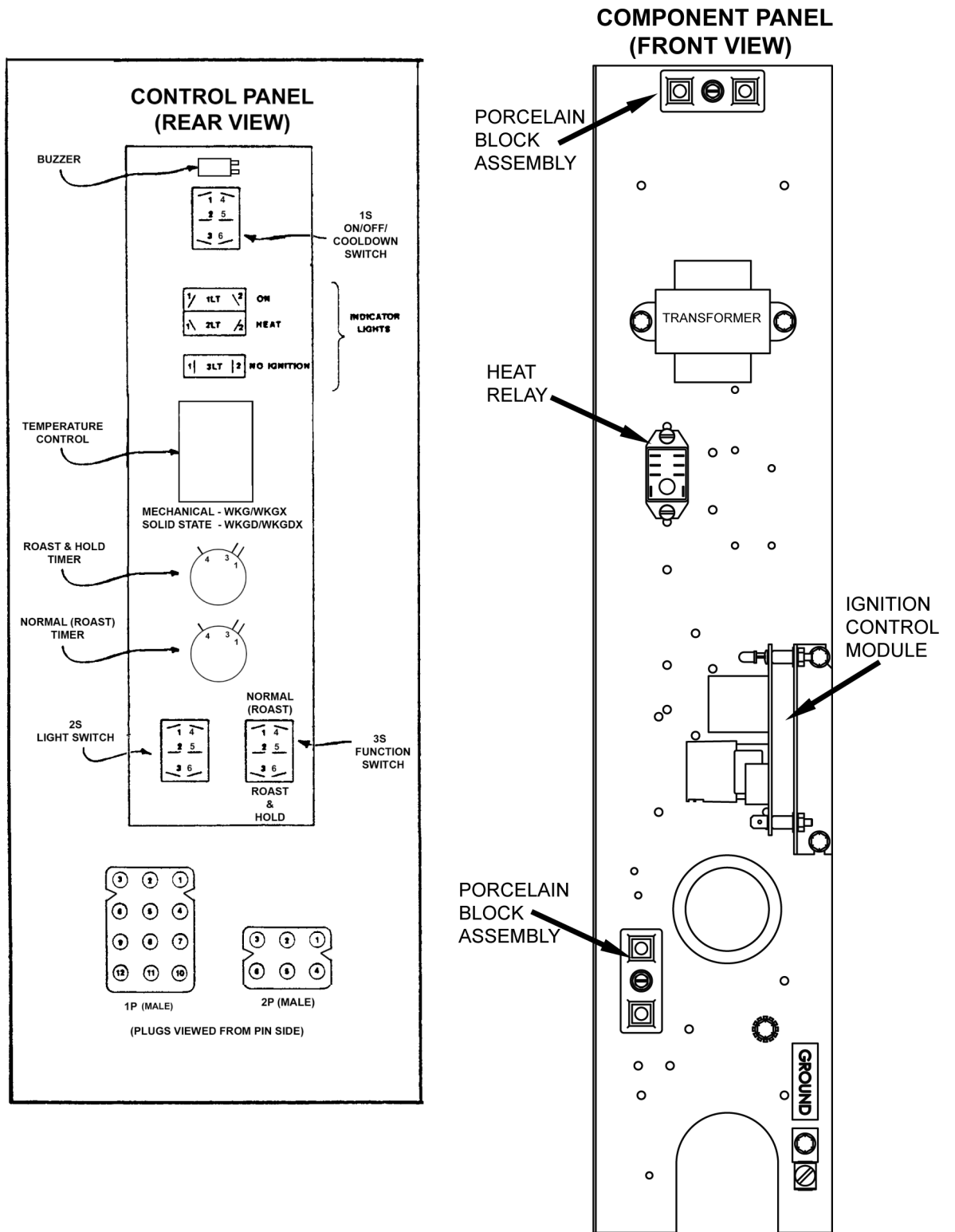

Fig. 72



DERIVED FROM 424207

AI4912

STARTING AT SERIAL NUMBER 481913936 (STANDARD)

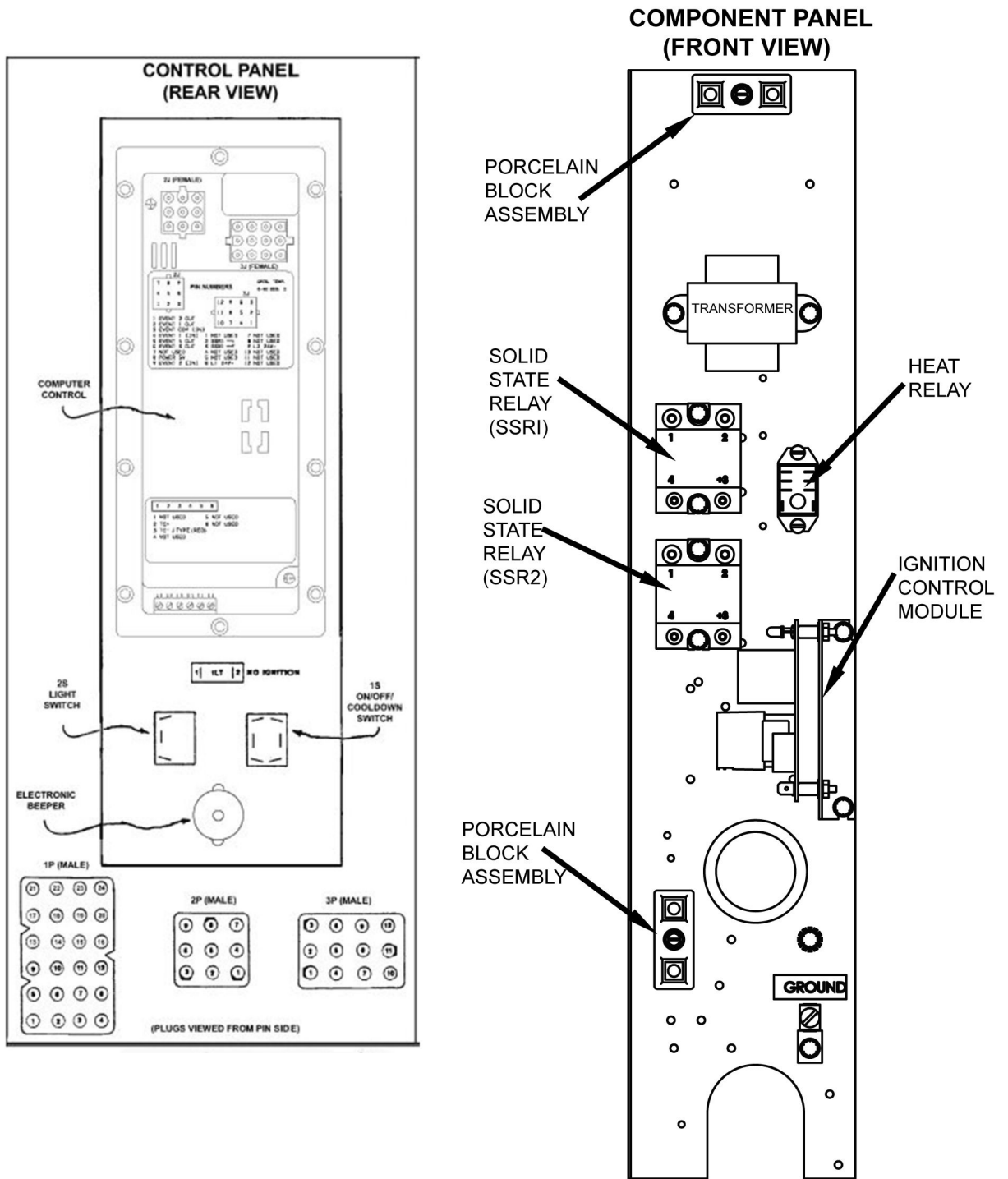

DERIVED FROM 424826

AI4913

STARTING AT SERIAL NUMBER 481913936 (COMPUTER)

SEQUENCE OF OPERATIONS

SG4D/SG6D with Solid State Temperature Controller

Schematic 424373-1 will be used to explain the electrical sequence of operation.

Cook Cycle

1. Conditions

- A. Oven connected to correct voltage.
 - 1) L1 (HOT) to power switch (S1).
 - 2) L2 (neutral or second line) to one side of the following components: L1 of the power level control, power ON light, heat light, temperature controller board terminal 9 (120VAC) or terminal 10 (208-240 VAC), oven cavity lights, buzzer, timer motor, heat relay coil (R3), convection fan motor common (C), transformer primary T1), motor speed (Hi/Low) relay coil (R1), hold relay coil (R2) and the component cooling fan.
 - B. Oven properly grounded.
 - C. Gas supply valve ON.
 - D. Gas combination control valve ON.
 - E. Power switch (S1) OFF.
 - F. Oven light switch (S2) ON/OFF (position has no affect on the function of the normal cooking cycle).
 - G. Temperature controller dial set to lowest temperature (fully counterclockwise).
 - H. High limit switch closed (position has no affect on the function of the normal cooking cycle).
 - I. Timer in the OFF position.
 - J. Oven doors closed.
 - K. Door switch contacts closed.
 - L. Oven cavity temperature below 140°F.
 - M. Power level switch to 100%.
2. Set temperature controller dial to desired temperature.
 - A. Contacts J3 and J5 close.
 3. Power switch (S1) is turned ON.

NOTE: Power is available to the oven light switch

 - A. Component cooling fan energized.
 - B. ON light (amber) is lit.
 - C. Power to timer terminal C.
 - D. Transformer (T1) energized.
 - 1) Power (24 VAC) to one side of the following components: heat relay (R3) normally open (N.O.) contact.
 - 2) First valve (safety) on the gas valve energized. Gas does not flow to the burner until the 2nd valve (main) is energized.
 - 3) Ignition module energized.
 - E. Heating light is lit.
 - F. Power to one side of centrifugal switch.
 - G. Convection fan motor is energized through (S3) high-low.
 - 1) When the convection fan motor reaches operating speed, the centrifugal switch (N.O.) on the motor closes.
 - H. Heat relay is energized.
 - 1) N.O. contacts close.
 4. Heating circuit is powered.
 - A. No ignition light (red) comes ON.
 - B. Module performs a self diagnostic test for 4 seconds.
 - C. Second valve (main) on the gas valve is energized. Gas starts to flow to burners.
 - D. Sparking begins, the no ignition light goes out and burners light.

NOTE: Sparking continues for up to 7 seconds or until a flame is established on both burners. If a flame is sensed on both burners, the no ignition light stays out and burner remains lit. If a flame is not sensed on both burners after 7 seconds of sparking, the no ignition light comes back on, second valve (main) on the gas valve is de-energized and gas flow to the burner stops. Ignition trial cycle repeats after a 15 second purge between cycles for two additional tries before locking out. To reset after a lockout, turn power switch (S1) OFF then ON.
 5. Oven reaches set temperature.
 - A. Temperature controller de-energizes internal relay and the normally open (N.O.) contacts open.
 - 1) Heat light goes out.
 - B. Power removed from heat relay.
 - C. Heat relay normally open (N.O.) contacts OPEN.
 - D. Power removed from heating circuit.
 - 1) Second gas valve de-energized.

6. The oven will continue to cycle on the temperature controller until the doors are opened or master switch (S1) is turned to the OFF or OVEN COOL position.

Timer Cycle

The timer operates independently of the heating cycle. Additional time can be set or the timer can be turned OFF throughout the cooking cycle.

1. With the master switch turned ON, power is supplied to timer.
 - A. Set the timer to desired time.
 - B. Contacts 1 & 3 close, timer motor is energized and timing down begins.
2. Time expires on timer.
 - A. Contacts 1 & 3 open, timer motor is de-energized and timing stops.
 - B. Contacts 1 & 4 close.
 - 1) Buzzer energized and sounds. The buzzer continues to sound until the timer dial is set to the OFF position or additional time is set.

Cool Down Cycle (Solid State Temperature Controller)

1. Conditions.
 - A. Oven is ON.
 - B. Oven cavity temperature needs to be lowered.
 - C. Doors are open.
 - 1) Convection fan de-energized.
 - 2) Thermostat de-energized.
 - a. Heat light out.
 - b. Power removed from heat relay.
 - 3) 24 V transformer de-energized.
 - 4) Cooling fan de-energized.
2. Power switch (S1) turned to COOL DOWN.
 - A. Power to fan speed switch (S3). Set fan speed switch to either HI or LO.
3. If door is closed, power is supplied to one side of the following components:
 - A. Power ON light (Amber) comes ON.
 - B. Transformer (T1) energized.

- 1) Power (24 VAC) to one side of the following components: heat relay (R3) normally open (N.O.) contacts, high limit connected through the normally closed (N.C.) contacts to the first valve (safety) on the dual solenoid gas valve.
 - a. First valve (safety) on the gas valve energized. Gas does not flow to the burner until the second valve (main) is energized.

- C. Component cooling fan.
- D. Power to timer and oven cavity lights.

4. The oven will remain in this condition until the master switch (S1) is turned to the OFF or ON position.

SG4C/SG6C with Computer Controller

Schematic 426575-1 will be used to explain the electrical sequence of operation.

Normal Cook Cycle

1. Conditions
 - A. Oven connected to correct voltage.
 - 1) L1 (hot) to power switch (S1).
 - 2) L2 (neutral or second line) to one side of the following components: oven cavity lights, convection fan motor common (C), transformer primary (T2), component cooling fan and the heat relay coil (R1).
 - B. Oven properly grounded.
 - 1) Ground (GND) to one side of the following components: computer control case, no ignition light, transformer secondary (T2), ignition control module, the first valve (safety) and second valve (main) on the dual solenoid gas valve and computer control pin 9 (C3-9).
 - C. Gas supply valve ON.
 - D. Gas combination control valve ON.
 - E. Power switch (S1) OFF.
 - F. Computer control is set up properly and ready to use.
 - G. Oven lights switch (S2) ON or OFF (position has no affect on the function of the normal cook cycle).
 - H. High limit thermostat closed.
 - I. Oven doors closed.

- J. Oven cavity temperature below 140°F.
- 2. Power switch (S1) turned ON.
 - A. Power (120 VAC) to computer control pin 3 (C3-3). Power at pin 3 is not transferred to other components until computer control is energized and operation conditions are met.
 - B. Power is available to the oven light switch (S2).
 - C. Power to terminal 1 on solid state relay 1 SSR1-load side and solid state relay 2 SSR2-load side.
 - D. Component cooling fan energized.
 - E. Transformer (T1) is energized, 24 volt output.
 - 1) Power (24 VAC) to one side of the following components: heat relay (R1) normally open (N.O.) contacts, high limit connected through the normally closed (N.C.) contacts to the first valve (safety) on the dual solenoid gas valve.
 - 2) First valve (safety) on the gas valve energized. Gas does not flow to the burner until the second valve (main) is energized.
 - 3) Ignition module energized.
 - 4) Power (24 VAC) to the oven computer control.
- 3. Control is energized and performs a power on self test before energizing outputs. If the control passes self test, then the outputs are energized and operation sequence continues, If control does not pass self test, then the corresponding error code is displayed.

NOTE: Control retains last temperature set.

- A. Computer control senses oven cavity temperature.
 - 1) With the oven cavity temperature below set point, the controls 120 VAC output from pin C3-2 is activated and power is connected to the common (C) side of the blower switch contacts on the convection fan motor.
 - 2) The controls 5 VDC output from pins C2-2 (-) and C2-8 (+) is activated and SSR1 relay is energized.
 - a. Convection fan motor is energized (fan speed on HI).

- 3) When the convection fan motor reaches operating speed:
 - a. The blower switch (N.O.) on the motor closes.
 - B. Heat relay coil (R1) energized.
 - 1) (R1) contacts (N.O.) close and the heating circuit is powered.
 - 2) Oven heat light on the control comes on.
 - C. Ignition module is energized.
 - 1) Heating circuit is powered.
 - 2) No ignition light (red) comes ON.
 - 3) Module performs a self-diagnostic test for 4 seconds.
 - 4) Second valve (main) on the gas valve is energized. Gas starts to flow to burners.
 - 5) Sparking begins, the no ignition light goes out and burners light.
- NOTE:** Sparking continues for up to 7 seconds or until a flame is established on both burners. If a flame is sensed on both burners, the no ignition light stays out and burner remains lit. If a flame is not sensed on both burners after 7 seconds of sparking, the no ignition light comes back on, second valve (main) on the gas valve is de-energized and gas flow to the burner stops. Ignition trial cycle repeats after a 15 second purge between cycles for two additional tries before locking out. To reset after a lockout, turn power switch (S1) OFF then ON.
- 4. Oven reaches set point temperature.
 - A. Computer control deactivates the 120 VAC output to heat relay (R1).
 - 1) Heat relay (R1) de-energized and the normally open (N.O.) contacts open.
 - B. Power removed from ignition control module.
 - 1) The second valve (main) on the gas valve is de-energized and gas flow to the burner stops.
 - 2) Oven heat LED on the control goes out.
 - 3) Oven ready LED on the control comes ON.
 - 4) Electronic beeper sounds momentarily.

- C. The oven will continue to cycle on the computer control until the doors are opened or power switch (S1) is turned to the OFF or COOL DOWN position.

Temperature and Time Cycle (Normal Cooking)

The computer's internal cook timer operates independently of the heating cycle. Additional time can be set or the timer can be stopped and restarted throughout the cooking cycle.

Refer to the Installation & Operation Manual for specific operation instructions of the oven computer control.

Function Switch SG4C/SG6C - Selects the cooking mode of the oven between Cook or Roast and Hold. Is used in conjunction with the Roast and Hold timer during Roast and Hold cooking. The selected mode also determines the fixed blower speed: HI for Cook and LO for Roast and Hold. If Roast and Hold is selected, when the Roast (then hold) time expires, the oven heating stops and the oven enters the hold mode. Once the oven cavity temperature drops to 150°F, the heat comes back on and the oven cycles at this temperature to hold the cooked product.

Roast and Hold Cycle

For a detailed explanation of the Roast and Hold mode, refer to the instructions manual.

In the Roast and Hold mode, the operation of the computer control is identical to the normal cook cycle, with these exceptions:

1. Oven Roast and Hold light on the control comes ON.
2. Convection fan speed changes from HI to LO.
 - A. The computer control 5 VDC output from pins C2-2 (-) and C2-8 (=) is deactivated and SSR1 relay is de-energized.

- 1) Power (120 VAC) is removed from convection fan motor high speed terminal.
- B. The computer control 5 VDC output from pins C2-1 (-) and C2-8 (+) is activated and SSR2 relay is energized.
 - 1) Power (120 VAC) is applied to the convection fan motor low speed terminal.
3. At the end of the cook time, the electronic beeper sounds momentarily to indicate the end of the first stage cooking (oven operates normally at the temperature and time selected until time expires).
4. The display flashes HOLD as the oven enters the hold mode. This is also considered second stage cooking (oven heating stops but product continues to cook on residual heat).
 - A. Convection fan motor is de-energized.
 - B. Oven fan cycles with the output of the heating system. Anytime the system calls for heat, the fan must be running. After the oven has reached the 150°F set temperature, the heat and fan are deenergized.
5. After the oven temperature drops below 150°F, the heat comes back on and cycles as needed to maintain the hold temperature of 150°F.
 - A. Convection fan motor energized.
6. The oven continues to cycle in this manner until one of the following occurs:
 - A. The cook and hold mode is turned OFF.
 - B. Power switch (S1) is turned to the OFF or COOL DOWN position.

WIRING DIAGRAMS

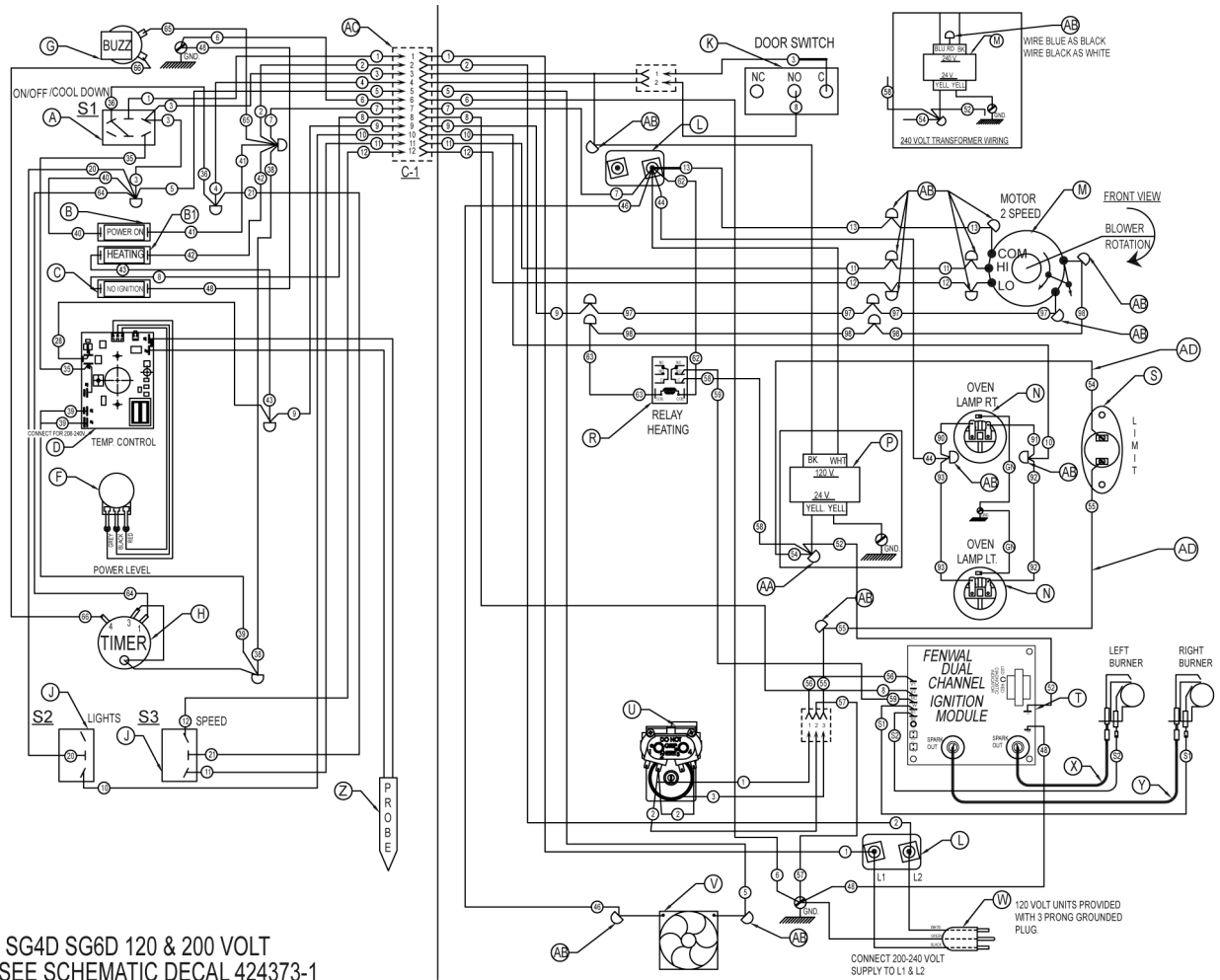
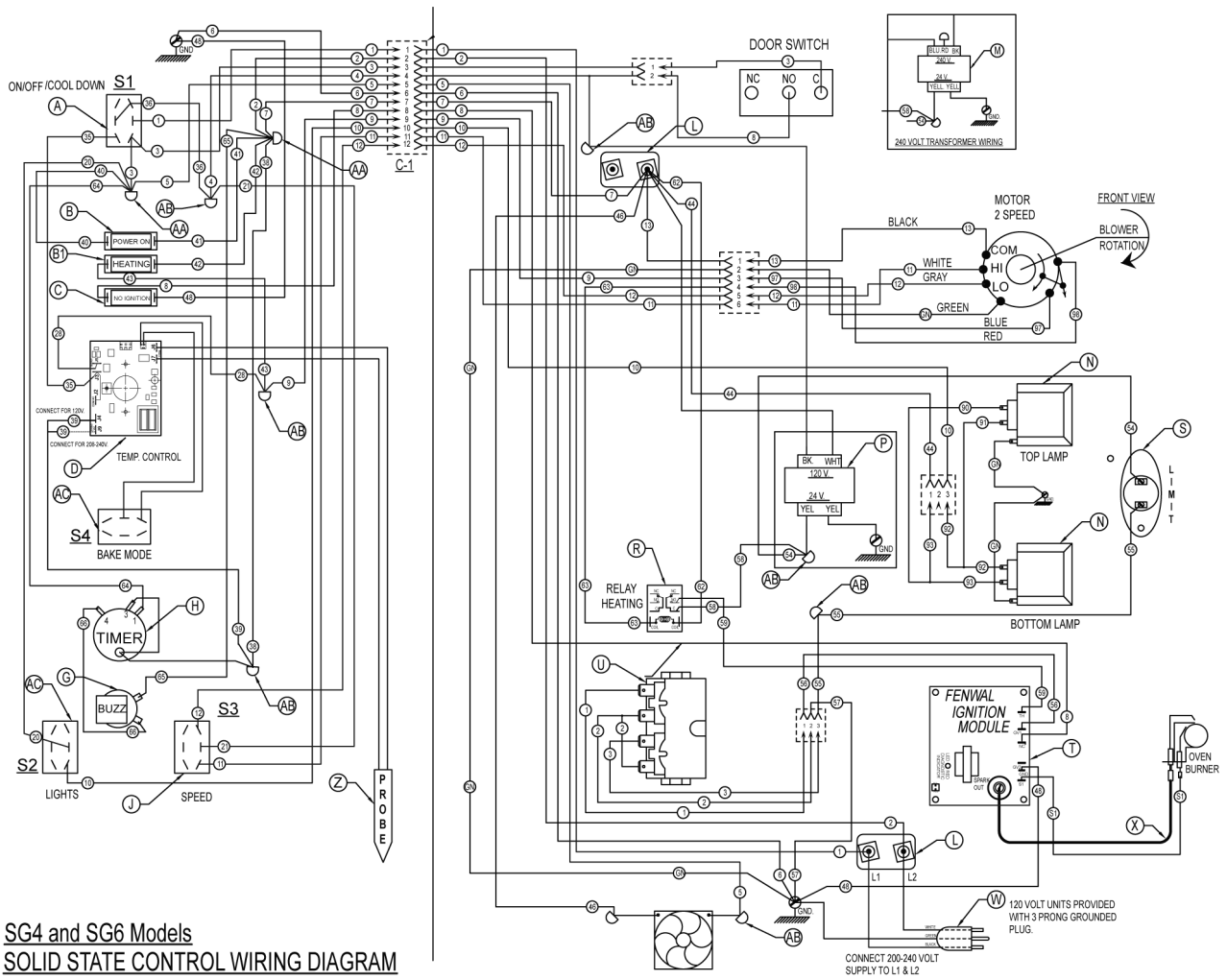

Fig. 75

AI4902



SG4 and SG6 Models
SOLID STATE CONTROL WIRING DIAGRAM
1 BURNER CONVECTION OVEN 120 & 240V (NEW SG4)
 DERIVED FROM 00959718

AI4891

STARTING AT SERIAL NUMBER 481913936

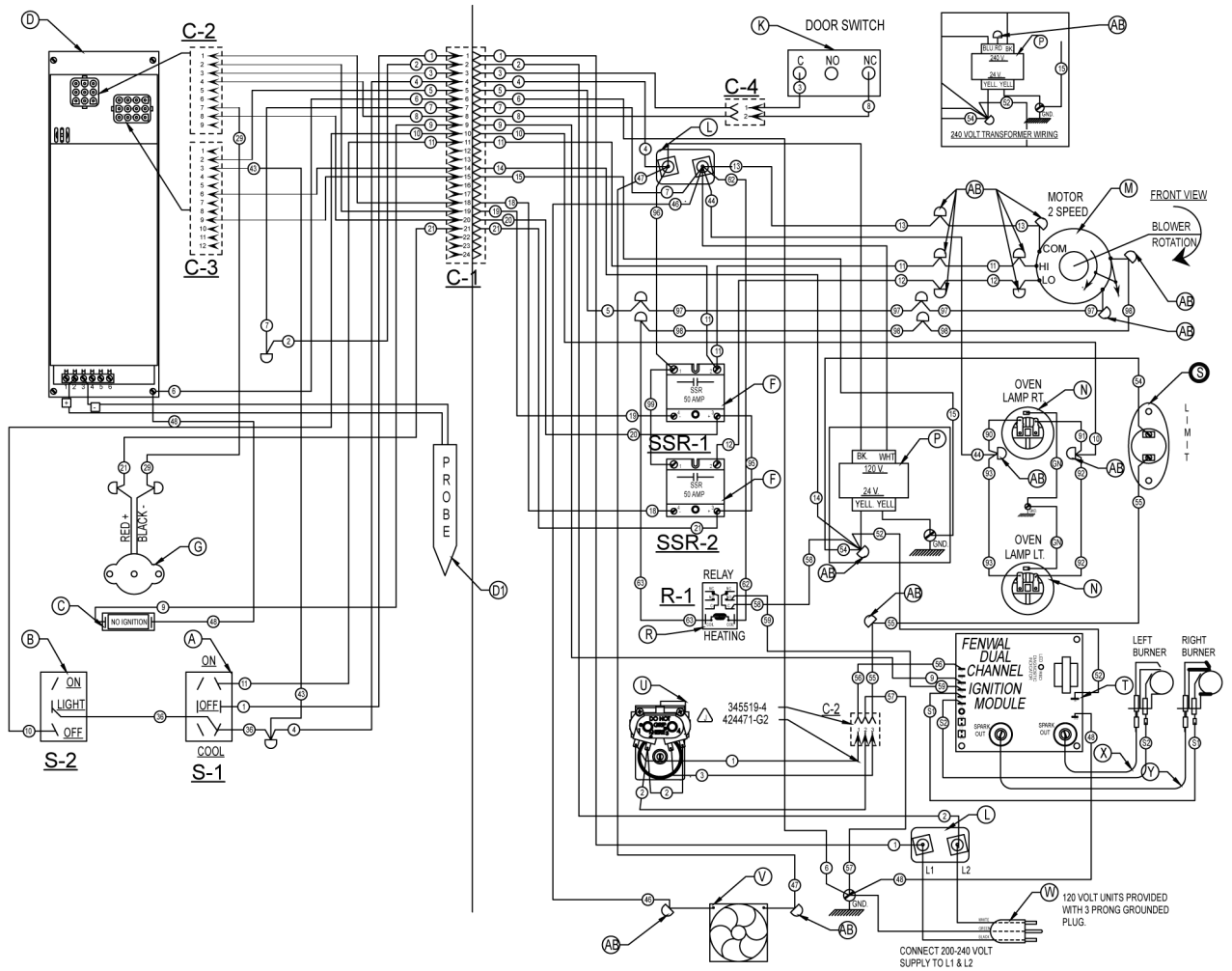

SG4 / SG6 CONVECTION OVEN DUAL BURNER - COMPUTER CONTROL 120 TO 240V.
 REFER TO SCHEMATIC 426575 - 1
 DERIVED FROM 426574 Rev. C

AI4903

Fig. 77

SCHEMATICS

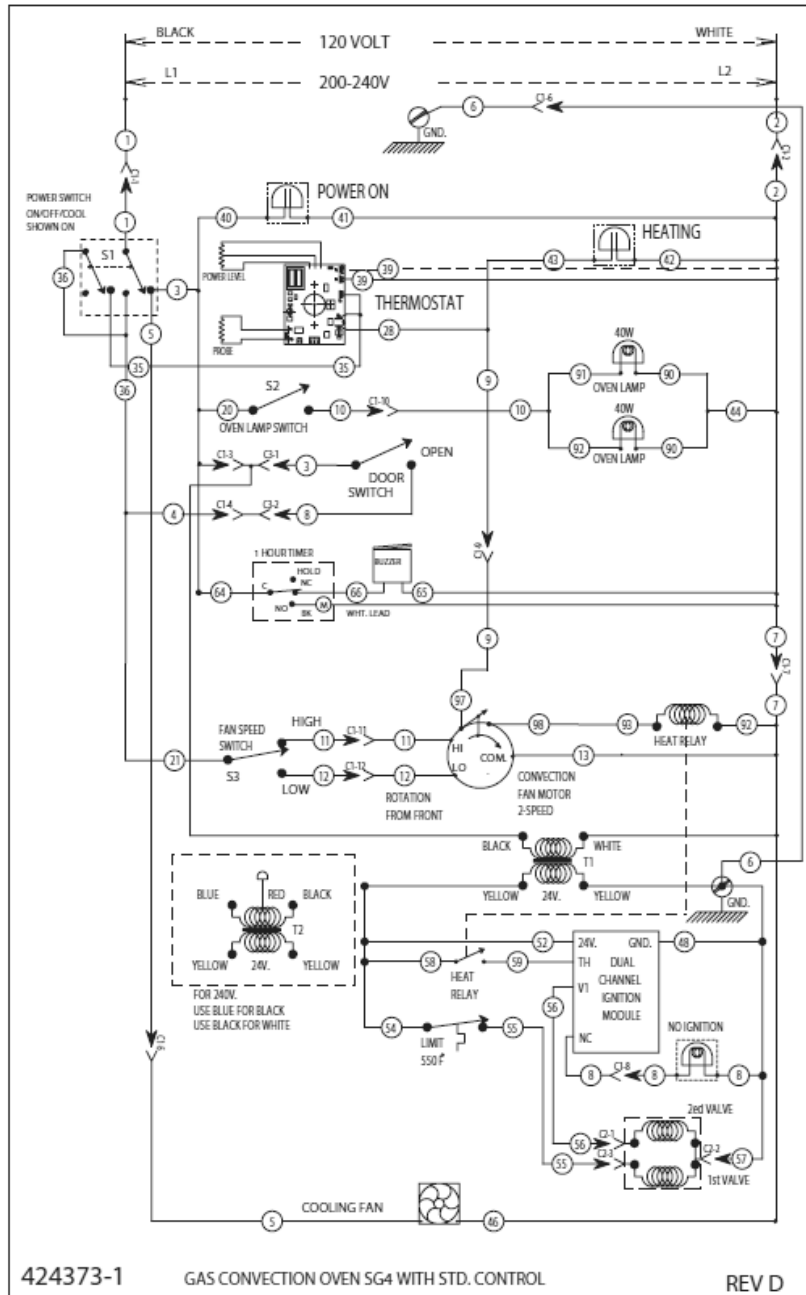

Fig. 78

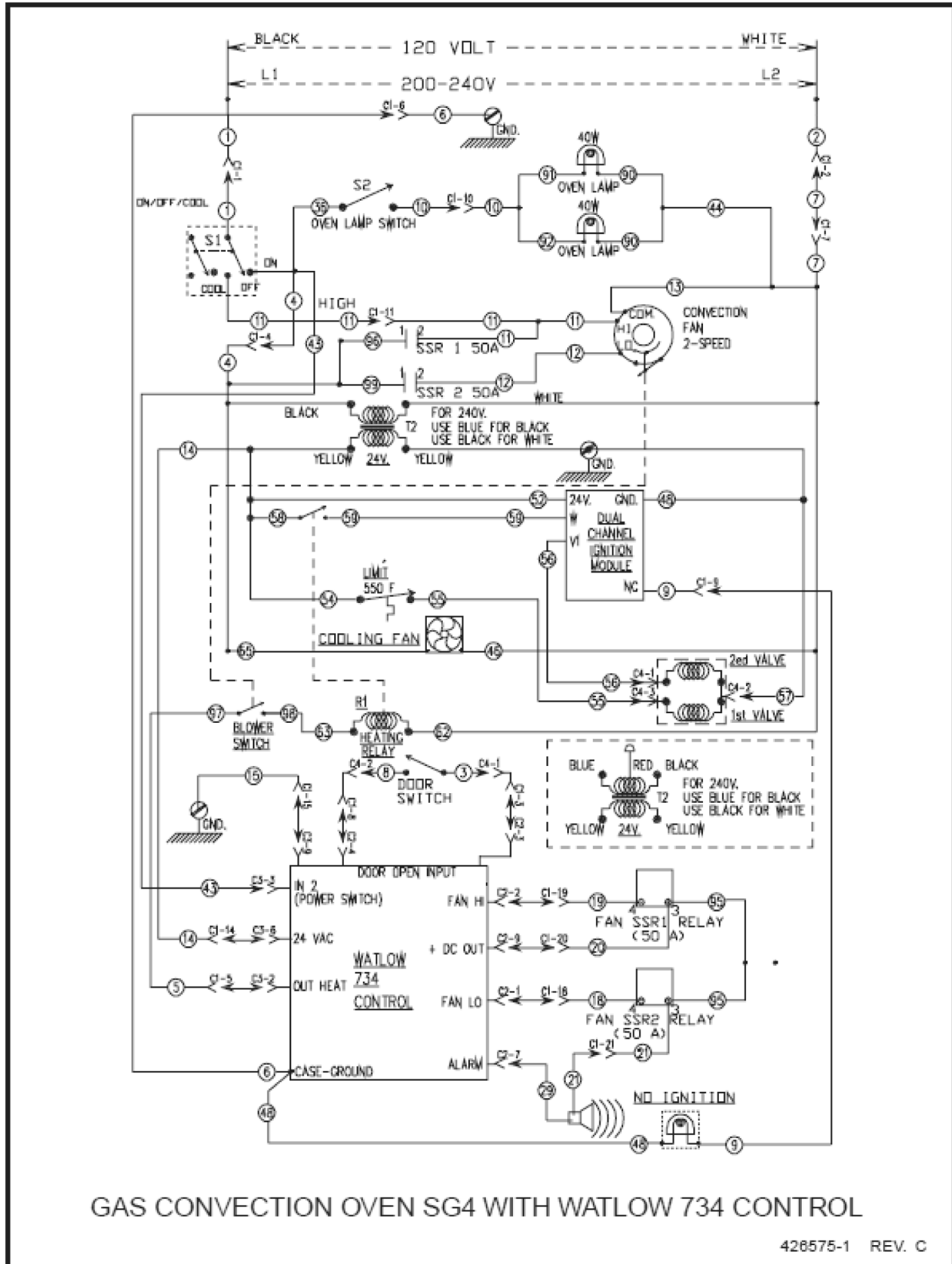

Fig. 79

TRUBLESHOOTING

TRUBLESHOOTING

SYMPTOMS	POSSIBLE CAUSES
Blower motor doesn't run in OVEN COOL or ON position.	Line voltage. Power/Master switch malfunction. Fan switch malfunction. Interconnection wiring malfunction.
Blower motor doesn't run in the ON position. Cool Down functions OK.	Door switch malfunction. Power/Master switch contacts inoperative. Interconnecting wiring malfunction.
Blower motor doesn't run in OVEN COOL position. Runs OK in ON position.	Power/Master switch malfunction. Interconnection wiring malfunction.
Gas does not ignite. No spark. No Ignition light is not ON.	Shorted electrode on igniter/flame sense. Igniter cable (high voltage) OPEN. Heat relay malfunction. Centrifugal switch in blower motor inoperative. Transformer inoperative. High limit thermostat open. Interconnecting wiring malfunction. Ignition module malfunction.
Sparks but gas does not ignite.	Gas solenoid valve off or inoperative. Manual gas valve closed. Gas supply OFF or insufficient gas pressure. Interconnecting wiring malfunction. Ignition module malfunction.
Gas ignites but will not maintain flame.	Igniter lead connections malfunction. Igniter ground inoperative. Igniter/flame sense malfunction or maladjusted. Insufficient gas pressure. Snorkel vent plugged, obstructed or missing. Incorrect polarity from transformer to ignition module.

SYMPTOMS	POSSIBLE CAUSES
Excessive or low heat.	Temperature probe malfunction. Temperature control board malfunction. Gas pressure insufficient. Gas orifice plugged or obstructed. Power level may be set to low.
Mechanical timer inoperative or not functioning properly.	Interconnecting wiring malfunction. Line voltage incorrect. Timer malfunction.
Component cooling fan does not run.	Motor inoperative. Interconnecting wiring malfunction.
Uneven cooking.	Convection fan motor speed/direction. Poor combustion. Gas pressure incorrect. Exhaust vent plugged or obstructed. Snorkel vent plugged or obstructed. Air flow baffles missing or damaged.
Intermittent problems.	High ambient temperatures. Wiring connections loose. Cooling fan malfunction.
No power to temperature controller.	Power/Master switch in OVEN COOL position. Door or door switch open.
No heat; LED on the controller is flashing.	Probe open or shorted.

COMPUTER CONTROL MODELS ONLY

SYMPTOM	POSSIBLE CAUSES
Oven does not heat.	High limit switch open. Probe malfunction. Control malfunction. Power level control set to off.
High limit thermostat shutting off gas burner.	Probe malfunction. Control malfunction.
Oven not hot enough.	Probe malfunction. Control range high (rH1) setting to low. See Setup Mode under Computer Controller (SG4C/SG6C).

ERROR CODES

CODE AND PROBLEM	PROBABLE CAUSE	SOLUTION
Er01 - ROM check sum error	Internal ROM malfunction	Cycle power.

CODE AND PROBLEM	PROBABLE CAUSE	SOLUTION
Er02 - RAM check sum error	Internal RAM malfunction	Cycle power.
Er03 - Ambient sensor error	Ambient temperature is below 32°F	Check ambient temperature at the control.
Er04 - Configuration error	Microprocessor malfunction	Cycle power.
Er05 - EEPROM error	Power loss while storing data	Cycle power.
Er06 - Zone 1 A/D under flow error	<ul style="list-style-type: none"> • Incorrect sensor type • Measuring temperature outside the sensor range 	<ul style="list-style-type: none"> • Check the InP1 setup parameter. Verify that it matches the sensor. • Check sensor and connections for a reversed or open sensor. If the condition causing the error is resolved, the error will clear.
Er07 - Zone 1 A/D overflow error	Open sensor	<ul style="list-style-type: none"> • Check the InP1 setup parameter. Verify that it matches the sensor. • Check sensor and connections for a reversed or open sensor. If the condition causing the error is resolved, the error will clear.
Er10 - Stack overflow error	Microprocessor malfunction	<ul style="list-style-type: none"> • Cycle Power. • Check sensor and connections for a reversed or open sensor.
Er11 - Open sensor error	Open sensor	<ul style="list-style-type: none"> • Check the InP1 setup parameter. Verify that it matches the sensor. • Check sensor and connections for a reversed or open sensor.
Er12 - Shorted sensor	<ul style="list-style-type: none"> • Incorrect sensor type • Measuring temperature outside the sensor range 	<ul style="list-style-type: none"> • Check the InP1 setup parameter. Verify that it matches the sensor. • Check sensor and connections for a reversed or open sensor.

IGNITION MODULE DIAGNOSTICS

NUMBER OF LED FLASHES	INDICATES	POSSIBLE CAUSE
2 Flashes	Burner flame with no call for heat.	<ol style="list-style-type: none"> 1. Main gas valve stuck open, burner on with no call for heat from the temperature control system. Replace main gas valve. 2. Check flame sensor and sensor wire. 3. Ignition module malfunction.

NUMBER OF LED FLASHES	INDICATES	POSSIBLE CAUSE
3 Flashes	Ignition system has locked out.	1. Ignition module could not "Prove" flame after three tries for ignition within the lockout time timing provided. <ul style="list-style-type: none"> A. Check for gas supply to burner. B. Check for spark to ignition electrode. <ul style="list-style-type: none"> 1) Check spark gap (gap should be 1/8"). C. Check for flame current in flame sense wire (0.000001 Amp Min. DC) using FC designated terminals. <ul style="list-style-type: none"> 1) Check burner adjustment (air/gas). <p>NOTE: If A thru C check out, replace ignition module.</p>
4 Flashes	Internal board problem.	1. Ignition module malfunction. Remove power from "R" terminal for five seconds then reconnect. If fault remains, replace ignition module.