



2026 PRODUCT CATALOG

VULCAN

CONTENTS

RANGES

Gas Restaurant Ranges (Endurance™ Series)	5
Electric Restaurant Ranges	22
Hot Plates	29
Stock Pot Ranges	31
Heavy Duty Ranges (V Series)	32
Mod Suite Custom Cookline Solutions	47

BROILERS

Heavy Duty Broilers	48
Salamander Broilers	51
Cheesemelters	53

OVEN

Full-Size Convection Ovens	55
Half-Size Convection Ovens	59

GRIDDLES

Gas Griddles	63
Electric Griddles	72
Manual Clamshell Griddle Accessory	76

CHARBROILERS

Gas Charbroilers	79
Smoker Bases	84
Counter Restaurant Series	85

STEAM

Counter Steamers	88
Floor Steamers	96
ScaleBlocker® Water Filtration	102
Braising Pans	103
2/3 Jacketed Kettles	110
Fully Jacketed Kettles	120
Steam Flow Requirements	123
Faucets	124

COMBI OVENS

Combi Ovens	126
-------------------	-----

FRYERS

Gas Fryers	144
Electric Fryers	162
FryMate™ Dump Station	167
Portable Filtration	169

HEATED HOLDING

Insulated Holding & Transport Cabinets	170
Insulated Correctional Cabinets	174
Non-Insulated Holding & Transport Cabinets	175
Cook & Hold Cabinets	176
Drawer Warmers	179
Chip Warmers	181

New Equipment Checkout	182
Terms and Conditions / Warranty	184

VULCAN LOCATIONS

BALTIMORE, MD

*Test Kitchen
Ovens, Ranges, & Broilers Plant*

3600 North Point Blvd.
Baltimore, MD 21222
410-284-0660

CHARLOTTE, NC

*Fryers, Griddles &
Charbroilers Plant*

10405 Westlake Drive
Charlotte, NC 28273
704-716-3100

LOUISVILLE, KY

Customer Service Office

325 W. Main Street
Louisville, KY 40202
502-778-2791

TROY, OH

Steam & Combi Plant

750 Lincoln Ave
Troy, OH 45373
937-332-3000

Exciting News: A New Home for Wolf and IBEX Catalogs!

To better serve you, the Wolf and IBEX catalogs now have dedicated spaces of their own. This change allows us to highlight what makes each brand unique while helping you find exactly what you're looking for—quickly and easily.

You can access the catalogs on each brand's website under the resources tab or by scanning the QR codes below.



WOLF
wolfequipment.com



IBEX
ibexoven.com

RANGES | How to Read Model Numbers

ENDURANCE™ RANGES

Width	Base Type	Burners	Gas Type
36	F	6B	P

Options (see specific product section for availability):

12	B = Cabinet	2B = 2 Burners	N = Natural Gas
24	C = Convection	4B = 4 Burners	P = Propane Gas (LP)
36	CC = Convection / Convection	6B = 6 Burners	
48	F = Flame Safety	8B = 8 Burners	
60	S = Standard	10B = 10 Burners	
72	SS = Standard / Standard	12B = 12 Burners	
	SC = Standard / Convection		
	R = Refrigerated Base		
	RC = Refrigerated / Convection		
	[] = No Base		

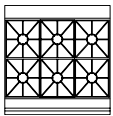

Width & Base Type Gas Type

36F-6BP
of Burners

= Endurance™ Series, 36" Flame Safety Range on standard base, 6 open-top burners, propane

EV SERIES (ELECTRIC) RANGES

Series	Width	Base Type	Count	Top Type	Width	Top Type	Volts
EV	36	S	4	FP	12	G	208

Options (see specific product section for availability):

12	C = Convection	2	G = Griddle	12	G = Griddle	208 (1/3 phase)
24	S = Standard	3	FP = French Plate	24		240 (1/3 phase)
36	SS = Standard / Standard	4	HT = Hot Top			480 (1/3 phase)
48	SC = Standard / Convection	5				
60		6				
		8				

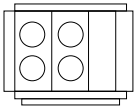

Series # of tops Width Volts
EV36S-4FP12G208
Width & Base type Top Type Top Type

= EV Series, 36" Range on standard base, 4 French Plates and 12" Griddle, 208 volt

OTHER EXAMPLES:

EV36S-2FP24G480 = 36" Range with 2 French Plates and 24" griddle, on standard base, 480 volt

EV60SS-6FP24G240 = 60" Range with 6 French Plates and 24" griddle, on 2 standard bases, 240 volt

ENDURANCE™ SERIES | *Powerful Versatility. Powerful Production.*

Besides total flexibility and adaptability to nearly any location, the Endurance™ Range offers Vulcan's legendary toughness, precision, and dependability. Loaded with innovative features, this medium duty range is sure to make an impact on your kitchen.

STANDARD FEATURES:

- Extra deep pull-out stainless steel crumb tray with welded corners.
- Cool-to-the-touch control knobs.
- Oven thermostat adjusts from 250–500°F.
- MIG welded frame ensures strong joints for long-lasting stability.
- 6" adjustable legs.
- Stainless steel front, sides, and lift-off high shelf.
- Each oven includes 2 racks and 4 rack positions.
- Heavy duty cast iron grates, easy lift-off 12" x 12" in front and 12" x 14" in back to accommodate large pans or stock pots.
- 30,000 BTU/hr open-top burners with lift-off heads for easy cleaning.
- 35,000 BTU/hr bakers depth standard oven allows 18" x 26" sheet pans to fit side-to-side or front-to-back in 36", 48", and 72" ranges (sheet pans fit front-to-back in 24" and one side of the 60" ranges).



36S-6B

Shown on optional casters

ENDURANCE™ SERIES | 12", 24" & 36" Open-Top Burners



12" RANGE 2 OPEN-TOP BURNERS

Cabinet Base	Gas Type	Total BTU/hr
12B-2BN	Natural	60,000
12B-2BP	Propane	55,000



12B-2B
Shown on optional casters



24" RANGE 4 OPEN-TOP BURNERS

Standard Base	Gas Type	Total BTU/hr
24S-4BN	Natural	143,000
24S-4BP	Propane	133,000

Ovens accept full-size sheet pans.



24S-4B
Shown on optional casters



36" RANGE 6 OPEN-TOP BURNERS

Standard Base	Gas Type	Total BTU/hr
36S-6BN	Natural	215,000
36S-6BP	Propane	200,000

Convection Base	Gas Type	Total BTU/hr
36C-6BN	Natural	212,000
36C-6BP	Propane	197,000

Refrigerated Base	Gas Type	Total BTU/hr
36R-6BN	Natural	180,000
36R-6BP	Propane	165,000

Ovens accept full-size sheet pans.

Configure your Vulcan Endurance™ Medium Duty Range with a fully integrated Traulsen twin drawer refrigerated base.

See page 21 for optional flame safety device for open-top burners.

Maximum BTUs shown are for base units and may vary with selected features.



36S-6B



36R-6B

Shown on optional casters



ENDURANCE™ SERIES | 36" Open-Top Burners & Griddle Top

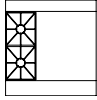

36" RANGE

2 OPEN-TOP BURNERS & 24" GRIDDLE RIGHT

	Standard Base	Griddle Control	Gas Type	Total BTU/hr
	36S-2B24GN	Manual	Natural	135,000
	36S-2B24GTN	Thermostatic	Natural	135,000
	36S-2B24GP	Manual	Propane	130,000
	36S-2B24GTP	Thermostatic	Propane	130,000
Convection Base				
	36C-2B24GN	Manual	Natural	132,000
	36C-2B24GTN	Thermostatic	Natural	132,000
	36C-2B24GP	Manual	Propane	127,000
	36C-2B24GTP	Thermostatic	Propane	127,000
Refrigerated Base				
	36R-2B24GN	Manual	Natural	100,000
	36R-2B24GTN	Thermostatic	Natural	100,000
	36R-2B24GP	Manual	Propane	95,000
	36R-2B24GTP	Thermostatic	Propane	95,000

- Ovens accept full-size sheet pans.
- Griddle can be moved to left position for upcharge.
- Manual griddle controls allow user to adjust temperature by turning the knob to adjust flame.
- Thermostatic griddle controls allow user to set and maintain a specific temperature.
- Maximum BTUs shown are for base units and may vary with selected features.

See page 21 for optional flame safety device for open-top burners.



36S-2B24GT
Shown on optional casters



36C-2B24GT
Shown on optional casters



36R-2B24GT
Shown on optional casters

ENDURANCE™ SERIES | 36" Open-Top Burners & Charbroiler Top



36" RANGE

2 OPEN-TOP BURNERS & 24" CHARBROILER RIGHT

Standard Base



36S-2B24CBN
36S-2B24CBP

Gas Type

Natural
Propane

Total BTU/hr

159,000
154,000

Convection Base



36C-2B24CBN
36C-2B24CBP

Natural
Propane

156,000
151,000

Refrigerated Base



36R-2B24CBN
36R-2B24CBP

Natural
Propane

124,000
119,000

- Ovens accept full-size sheet pans.
- 24" Charbroilers can only be on the right.

See page 21 for optional flame safety device for open-top burners.



36C-2B24CB

Shown on optional casters



36C-36CB

Shown on optional casters



36CR-36CB

Shown on optional casters



36" RANGE

36" CHARBROILER TOP

Standard Base



36S-36CBN
36S-36CBP

Gas Type

Natural
Propane

Total BTU/hr

131,000
131,000

Convection Base



36C-36CBN
36C-36CBP

Natural
Propane

125,000
125,000

Refrigerated Base



36R-36CBN
36R-36CBP

Natural
Propane

96,000
96,000

- Ovens accept full-size sheet pans.
- Maximum BTUs shown are for base units and may vary with selected features.

ENDURANCE™ SERIES | 36" Griddle Top



36" RANGE 36" GRIDDLE TOP

	Standard Base	Griddle Control	Gas Type	Total BTU/hr
	36S-36GN	Manual	Natural	95,000
	36S-36GTN	Thermostatic	Natural	95,000
	36S-36GP	Manual	Propane	95,000
	36S-36GTP	Thermostatic	Propane	95,000
Convection Base				
	36C-36GN	Manual	Natural	92,000
	36C-36GTN	Thermostatic	Natural	92,000
	36C-36GP	Manual	Propane	92,000
	36C-36GTP	Thermostatic	Propane	92,000
Refrigerated Base				
	36R-36GN	Manual	Natural	60,000
	36R-36GTN	Thermostatic	Natural	60,000
	36R-36GP	Manual	Propane	60,000
	36R-36GTP	Thermostatic	Propane	60,000

- Ovens accept full-size sheet pans.
- Manual griddle controls allow user to adjust temperature by turning the knob to adjust flame.
- Thermostatic griddle controls allow user to set and maintain a specific temperature.
- Maximum BTUs shown are for base units and may vary with selected features.



36S-36GT
Shown on optional casters



36R-36GT
Shown on optional casters

ENDURANCE™ SERIES | 48" Open-Top Burners

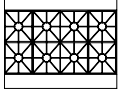

48" RANGE

8 OPEN-TOP BURNERS & 12" STORAGE BASE

Standard Base



48S-8BN
48S-8BP

Gas Type

Natural
Propane

Total BTU/hr

275,000
255,000

Convection Base



48C-8BN
48C-8BP

Natural
Propane

272,000
252,000

Refrigerated Base - Left placement only



48R-8BN
48R-8BP

Natural
Propane

240,000
220,000

- Ovens accept full-size sheet pans.

See page 21 for optional flame safety device for open-top burners.



48S-8BN

Shown on optional casters

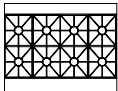

48" RANGE

8 OPEN-TOP BURNERS & 2 STANDARD OVENS

2 Standard Bases



48SS-8BN
48SS-8BP

Gas Type

Natural
Propane

Total BTU/hr

286,000
266,000

- Ovens accept full-size sheet pans.
- Maximum BTUs shown are for base units and may vary with selected features.

See page 21 for optional flame safety device for open-top burners.



48SS-8BN

Shown on optional casters

ENDURANCE™ SERIES | 48" Open-Top Burners & Griddle Top

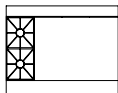

48" RANGE

2 OPEN-TOP BURNERS, 36" GRIDDLE RIGHT & 12" STORAGE BASE

	Standard Base	Griddle Control	Gas Type	Total BTU/hr
	48S-2B36GN	Manual	Natural	155,000
	48S-2B36GTN	Thermostatic	Natural	155,000
	48S-2B36GP	Manual	Propane	150,000
	48S-2B36GTP	Thermostatic	Propane	150,000
Convection Base				
	48C-2B36GN	Manual	Natural	152,000
	48C-2B36GTN	Thermostatic	Natural	152,000
	48C-2B36GP	Manual	Propane	147,000
	48C-2B36GTP	Thermostatic	Propane	147,000
Refrigerated Base - Left placement only				
	48R-36G2BN	Manual	Natural	120,000
	48R-36GT2BN	Thermostatic	Natural	120,000
	48R-36G2BP	Manual	Propane	115,000
	48R-36GT2BP	Thermostatic	Propane	115,000

- Ovens accept full-size sheet pans.
- Griddles and oven bases can be moved to left position for upcharge.
- Griddles can only be placed over the 36" oven base section.
- Convection ovens can only be in the 36" oven base.
- Manual griddle controls allow user to adjust temperature by turning the knob to adjust flame.
- Thermostatic griddle controls allow user to set and maintain a specific temperature.
- Maximum BTUs shown are for base units and may vary with selected features.

See page 21 for optional flame safety device for open-top burners.



48S-2B36G
Shown on optional casters

ENDURANCE™ SERIES | 48" Open-Top Burners & Griddle Top

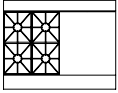

48" RANGE

4 OPEN-TOP BURNERS, 24" GRIDDLE RIGHT & 12" STORAGE BASE

Standard Base		Griddle Control	Gas Type	Total BTU/hr
	48S-4B24GN	Manual	Natural	195,000
	48S-4B24GTN	Thermostatic	Natural	195,000
	48S-4B24GP	Manual	Propane	185,000
	48S-4B24GTP	Thermostatic	Propane	185,000
Convection Base				
	48C-4B24GN	Manual	Natural	192,000
	48C-4B24GTN	Thermostatic	Natural	192,000
	48C-4B24GP	Manual	Propane	182,000
	48C-4B24GTP	Thermostatic	Propane	182,000
Refrigerated Base - Left placement only				
	48R-24G4BN	Manual	Natural	120,000
	48R-24GT4BN	Thermostatic	Natural	120,000
	48R-24G4BP	Manual	Propane	110,000
	48R-24GT4BP	Thermostatic	Propane	110,000

- Ovens accept full-size sheet pans.
- Griddles and oven bases can be moved to left position for upcharge.
- Griddles can only be placed over the 36" oven base section. Convection ovens can only be in the 36" oven base.
- Manual griddle controls allow user to adjust temperature by turning the knob to adjust flame.
- Thermostatic griddle controls allow user to set and maintain a specific temperature.
- Maximum BTUs shown are for base units and may vary with selected features.

See page 21 for optional flame safety device for open-top burners.



48S-4B24G
Shown on optional casters

ENDURANCE™ SERIES | 60" Open-Top Burners

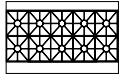

60" RANGE WITH 2 OVENS 10 OPEN-TOP BURNERS

Standard Base / Standard Base		Gas Type	Total BTU/hr	
		60SS-10BN	Natural	385,000
		60SS-10BP	Propane	360,000
Standard Base / Convection Base				
		60SC-10BN	Natural	355,000
		60SC-10BP	Propane	330,000
Refrigerated Base (Left placement only) / Standard Base				
		60RS-10BN	Natural	323,000
		60RS-10BP	Propane	298,000

- Ovens accept full-size sheet pans.
- Convection ovens can only be in the 36" oven base.
- Maximum BTUs shown are for base units and may vary with selected features.

See page 21 for optional flame safety device for open-top burners.



60SS-10BN
Shown on optional casters

ENDURANCE™ SERIES | 60" Open-Top Burners & Griddle Top

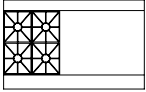

60" RANGE

4 OPEN-TOP BURNERS, 36" GRIDDLE RIGHT

Standard Base / Standard Base	Griddle Control	Gas Type	Total BTU/hr
60SS-4B36GN	Manual	Natural	238,000
60SS-4B36GTN	Thermostatic	Natural	238,000
60SS-4B36GP	Manual	Propane	228,000
60SS-4B36GTP	Thermostatic	Propane	228,000
Standard Base / Convection Base			
60SC-4B36GN	Manual	Natural	235,000
60SC-4B36GTN	Thermostatic	Natural	235,000
60SC-4B36GP	Manual	Propane	225,000
60SC-4B36GTP	Thermostatic	Propane	225,000
Refrigerated Base (Left placement only) / Standard Base			
60RS-36G4BN	Manual	Natural	203,000
60RS-36GT4BN	Thermostatic	Natural	203,000
60RS-36G4BP	Manual	Propane	193,000
60RS-36GT4BP	Thermostatic	Propane	193,000

- Ovens accept full-size sheet pans.
- Griddles and oven bases can be moved to left position for upcharge.
- Griddles can only be placed over the 36" oven base section. Convection ovens can only be in the 36" oven base.
- Manual griddle controls allow user to adjust temperature by turning the knob to adjust flame.
- Thermostatic griddle controls allow user to set and maintain a specific temperature.
- Maximum BTUs shown are for base units and may vary with selected features.

See page 21 for optional flame safety device for open-top burners.



60SC-4B36GT
Shown on optional casters

ENDURANCE™ SERIES | 60" Open-Top Burners & Griddle Top

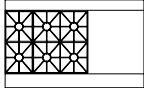

60" RANGE WITH 2 OVENS

6 OPEN-TOP BURNERS, 24" GRIDDLE RIGHT

Standard Base / Standard Base	Griddle Control	Gas Type	Total BTU/hr
60SS-6B24GN	Manual	Natural	278,000
60SS-6B24GTN	Thermostatic	Natural	278,000
60SS-6B24GP	Manual	Propane	263,000
60SS-6B24GTP	Thermostatic	Propane	263,000
Standard Base / Convection Base			
60SC-6B24GN	Manual	Natural	275,000
60SC-6B24GTN	Thermostatic	Natural	275,000
60SC-6B24GP	Manual	Propane	260,000
60SC-6B24GTP	Thermostatic	Propane	260,000
Refrigerated Base (Left placement only) / Standard Base			
60RS-24G6BN	Manual	Natural	243,000
60RS-24GT6BN	Thermostatic	Natural	243,000
60RS-24G6BP	Manual	Propane	228,000
60RS-24GT6BP	Thermostatic	Propane	228,000

- Ovens accept full-size sheet pans.
- Griddles and oven bases can be moved to left position for upcharge.
- Griddles can only be placed over the 36" oven base section. Convection ovens can only be in the 36" oven base.
- Manual griddle controls allow user to adjust temperature by turning the knob to adjust flame.
- Thermostatic griddle controls allow user to set and maintain a specific temperature.
- Maximum BTUs shown are for base units and may vary with selected features.

See page 21 for optional flame safety device for open-top burners.



60SS-6B24GTN
Shown on optional casters

ENDURANCE™ SERIES | 60" Open-Top Burners & Griddle Top

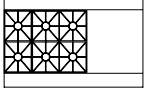

60" RANGE WITH 2 OVENS

6 OPEN-TOP BURNERS & 24" GRIDDLE / BROILER RIGHT

Standard Base / Standard Base	Griddle Control	Gas Type	Total BTU/hr
60SS-6B24GBN	Manual	Natural	278,000
60SS-6B24GBP	Manual	Propane	263,000

Standard Base / Convection Base

60SC-6B24GBN	Manual	Natural	275,000
60SC-6B24GBP	Manual	Propane	260,000

- Ovens accept full-size sheet pans.
- Manual griddle controls allow user to adjust temperature by turning the knob to adjust flame.

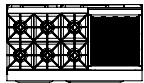

60" RANGE WITH 2 OVENS

6 OPEN-TOP BURNERS & 24" CHARBROILER RIGHT

Standard Base / Standard Base	Gas Type	Total BTU/hr
60SS-6B24CBN	Natural	302,000
60SS-6B24CBP	Propane	287,000

Standard Base / Convection Base

60SC-6B24CBN	Natural	299,000
60SC-6B24CBP	Propane	284,000

- Ovens accept full-size sheet pans.
- Charbroilers can only be on the right
- Charbroilers can only be placed over the 36" oven base.
- Convection ovens can only be in the 36" oven base.



60SC-6B24CBN

See page 21 for optional flame safety device for open-top burners.

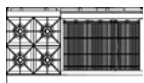

60" RANGE WITH 2 OVENS

4 OPEN-TOP BURNERS & 36" CHARBROILER RIGHT

Standard Base / Standard Base	Gas Type	Total BTU/hr
60SS-4B36CBN	Natural	274,000
60SS-4B36CBP	Propane	261,000

Standard Base / Convection Base

60SC-4B36CBN	Natural	271,000
60SC-4B36CBP	Propane	261,000

- Ovens accept full-size sheet pans. Charbroilers can only be on the right.
- Charbroilers can only be placed over the 36" oven base.
- Convection ovens can only be in the 36" oven base.
- Maximum BTUs shown are for base units and may vary with selected features.

ENDURANCE™ SERIES | 72" Open-Top Burners & Griddle Top

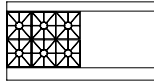

72" RANGE WITH 2 OVENS

6 OPEN-TOP BURNERS & 36" GRIDDLE RIGHT

Standard Base / Standard Base		Griddle Control	Gas Type	Total BTU/hr
	72SS-6B36GN	Manual	Natural	310,000
	72SS-6B36GTN	Thermostatic	Natural	310,000
	72SS-6B36GP	Manual	Propane	295,000
	72SS-6B36GTP	Thermostatic	Propane	295,000
Standard Base / Convection Base				
	72SC-6B36GN	Manual	Natural	307,000
	72SC-6B36GTN	Thermostatic	Natural	307,000
	72SC-6B36GP	Manual	Propane	292,000
	72SC-6B36GTP	Thermostatic	Propane	292,000
Convection Base / Convection Base				
	72CC-6B36GN	Manual	Natural	304,000
	72CC-6B36GTN	Thermostatic	Natural	304,000
	72CC-6B36GP	Manual	Propane	289,000
	72CC-6B36GTP	Thermostatic	Propane	289,000
Refrigerated Base (Left placement only) / Standard Base				
	72RS-6B36GN	Manual	Natural	275,000
	72RS-6B36GTN	Thermostatic	Natural	275,000
	72RS-6B36GP	Manual	Propane	260,000
	72RS-6B36GTP	Thermostatic	Propane	260,000
Refrigerated Base (Left placement only) / Convection Base				
	72RC-6B36GN	Manual	Natural	272,000
	72RC-6B36GTN	Thermostatic	Natural	272,000
	72RC-6B36GP	Manual	Propane	257,000
	72RC-6B36GTP	Thermostatic	Propane	257,000

- Ovens accept full-size sheet pans.
- Griddles and convection ovens can be moved to left position for upcharge.
- Manual griddle controls allow user to adjust temperature by turning the knob to adjust flame.
- Thermostatic griddle controls allow user to set and maintain a specific temperature.
- Maximum BTUs shown are for base units and may vary with selected features.

See page 21 for optional flame safety device for open-top burners.

ENDURANCE™ SERIES | 72" Open-Top Burners & Griddle Top

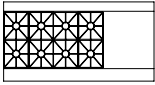

72" RANGE WITH 2 OVENS

8 OPEN-TOP BURNERS & 24" GRIDDLE RIGHT

Standard Base / Standard Base



	Griddle Control	Gas Type	Total BTU/hr
72SS-8B24GN	Manual	Natural	350,000
72SS-8B24GTN	Thermostatic	Natural	350,000
72SS-8B24GP	Manual	Propane	330,000
72SS-8B24GTP	Thermostatic	Propane	330,000

Standard Base / Convection Base



72SC-8B24GN	Manual	Natural	347,000
72SC-8B24GTN	Thermostatic	Natural	347,000
72SC-8B24GP	Manual	Propane	327,000
72SC-8B24GTP	Thermostatic	Propane	327,000

Convection Base / Convection Base



72CC-8B24GN	Manual	Natural	344,000
72CC-8B24GTN	Thermostatic	Natural	344,000
72CC-8B24GP	Manual	Propane	324,000
72CC-8B24GTP	Thermostatic	Propane	324,000

Refrigerated Base (Left placement only) / Standard Base



72RS-8B24GN	Manual	Natural	315,000
72RS-8B24GTN	Thermostatic	Natural	315,000
72RS-8B24GP	Manual	Propane	295,000
72RS-8B24GTP	Thermostatic	Propane	295,000

Refrigerated Base (Left placement only) / Convection Base



72RC-8B24GN	Manual	Natural	312,000
72RC-8B24GTN	Thermostatic	Natural	312,000
72RC-8B24GP	Manual	Propane	312,000
72RC-8B24GTP	Thermostatic	Propane	312,000

- Ovens accept full-size sheet pans.
- Griddles and convection ovens can be moved to left position for upcharge.
- Manual griddle controls allow user to adjust temperature by turning the knob to adjust flame.
- Thermostatic griddle controls allow user to set and maintain a specific temperature.
- Maximum BTUs shown are for base units and may vary with selected features.

See page 21 for optional flame safety device for open-top burners.

ENDURANCE™ SERIES | 72" Open-Top Burners

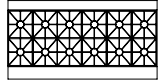

72" RANGE WITH 2 OVENS 12 OPEN-TOP BURNERS

Standard / Standard Base		Gas Type	Total BTU/hr
	72SS-12BN	Natural	430,000
	72SS-12BP	Propane	400,000
Standard / Convection Base			
	72SC-12BN	Natural	427,000
	72SC-12BP	Propane	397,000
Convection / Convection Base			
	72CC-12BN	Natural	424,000
	72CC-12BP	Propane	394,000
Refrigerated Base (Left placement only) / Standard Base			
	72RS-12BN	Natural	395,000
	72RS-12BP	Propane	365,000
Refrigerated Base (Left placement only) / Convection Base			
	72RC-12BN	Natural	392,000
	72RC-12BP	Propane	362,000

- Ovens accept full-size sheet pans.
- Convection ovens can be positioned left for upcharge.
- Maximum BTUs shown are for base units and may vary with selected features.

See page 21 for optional flame safety device for open-top burners.







72SS-12BN
Shown on optional casters

ENDURANCE™ SERIES | *Field-Installed Accessories*

	DESCRIPTION	ITEM #	FOR
	FRYER SHIELD Stainless steel fryer shield to protect from grease splatters	SHIELD-FRYLH	All size ranges
		SHIELD-FRYRH	All size ranges
	EXTRA OVEN RACK Extra oven rack with guides	OVNRACK-XL20	24", 48", 60" range
		OVNRACK-XL26	36", 48", 60", 72" range
	STUB RISER 4" Stainless steel backguard flue riser, 4" stub back	STUB4-XL24	24" range
		STUB4-XL36	36" range
		STUB4-XL48	48" range
		STUB4-XL60	60" range
		STUB4-XL72	72" range
	STUB RISER 10" Stainless steel backguard flue riser, 10" stub back	STUB10-XL24	24" range
		STUB10-XL36	36" range
		STUB10-XL48	48" range
		STUB10-XL60	60" range
		STUB10-XL72	72" range
	TOWEL BAR Stainless steel bar allows for conveniently hanging towels, oven mitts or other kitchen items	RCTWLBR-24	24" range
		RCTWLBR-36	36" range
		RCTWLBR-48	48" range
		RCTWLBR-60	60" range
		RCTWLBR-72	72" range
	CONDIMENT RAIL Stainless steel rail allows for convenient housing of frequently used condiments	RCCONRL-24	24" range
		RCCONRL-36	36" range
		RCCONRL-48	48" range
		RCCONRL-60	60" range
		RCCONRL-72	72" range
	REINFORCED HIGH SHELF Multi-functional stainless steel shelf to mount a salamander or cheesemelter above the range, or for extra storage space for frequently used items	RSHELF-XL24	24" range
		RSHELF-XL36	36" range
		RSHELF-XL48	48" range
		RSHELF-XL60	60" range
		RSHELF-XL72	72" range

ENDURANCE™ SERIES | *Field-Installed Accessories*

	DESCRIPTION	ITEM #	FOR
	CASTERS Set of 4 casters, 6" high (2 locking)	CASTERS-RR4	All size ranges. 2 sets required on 48" and larger units
	ADJUSTABLE CASTERS Set of 4 adjustable casters, 6" high (2 locking)	CASTERS-ADJRR4	All size ranges. 2 sets required on 48" and larger units
	FLANGED FEET Set of 4 stainless steel adjustable flanged feet, 6-7½" high	VFLANGD-FEET/4	All size ranges. 2 sets required on 48" and larger units
	INTERPLUMB KIT Inter-plumbing gas connection kit (requires rear gas connection on range) for connecting salamander to range	CONNECT-CHALL	Salamanders and cheesemelters
	QUICK DISCONNECT HOSE Quick disconnect hose with restraining device	3/4QD-HOSE-4 ¾" x 4'	24" & 36" ranges
		1INFLEX-FT 1" x 4'	48" and larger ranges

FACTORY-INSTALLED OPTIONS

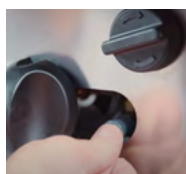

Item #	Description
F-DEVICE	Spark igniter with flame safety device for open-top burners and griddles (per 12" section). Flame safety device generates a spark to light the standing pilot.
OTB-STEPUP	Convert a rear open-top burner to a step up rear open-top burner (1-12" Section).

EV SERIES | Standard Features

Our EV Series Electric Ranges are built to meet the demand of today's electric foodservice kitchens; combining durability with quality features that enhance ease of use, efficiency, and productivity. Designed with heavy duty components, they can be sold as medium or heavy duty electric ranges.

STANDARD FEATURES:

- Extra deep pull-out stainless steel crumb tray with welded corners.
- 5 kW Hot Top Sections with thermostatic controls, ideal for long-term cooking, and larger pots and pans.
- 5 kW bakers depth standard oven allows 18" x 26" sheet pans to fit side-to-side or front-to-back in the 36" range and front-to-back in 24" and 60" ranges.
- MIG welded frame ensures strong joints for long-lasting stability.
- ¾" thick griddle plates with thermostatic controls.
- Shipped 3 Phase and are easily field convertible to 1 Phase.
- Stainless steel front, sides, and lift-off high shelf.
- 2 kW French Plates with infinite heat controls, ideal for sauté pans.
- Top browning control.
- Cool-to-the-touch control knobs.
- Oven thermostat adjusts from 250–500°F with low setting.
- 1 oven rack and 4 rack positions.
- 6" adjustable legs.



EV36S-6FP
Shown with optional casters

Pictures shown are for illustration purpose only. Actual product may vary.

EV SERIES | 12" & 24" French Plates & Hot Tops

12" ELECTRIC RANGE (NO OVEN)

2 FRENCH PLATES, GRIDDLE OR HOT TOP SECTION

Base N/A		Top Configuration	Volts	Phase
EV12-2FP208		2 French Plates	208	1 / 3
EV12-2FP240		2 French Plates	240	1 / 3
EV12-2FP480		2 French Plates	480	1 / 3
EV12-1HT208		1 Hot Top	208	1 Only
EV12-1HT240		1 Hot Top	240	1 Only
EV12-1HT480		1 Hot Top	480	1 Only
EV12-12G208		1 Griddle	208	1 Only
EV12-12G240		1 Griddle	240	1 Only
EV12-12G480		1 Griddle	480	1 Only



EV12-2FP

24" ELECTRIC RANGE WITH 1 OVEN

4 FRENCH PLATES OR 2 HOT TOP SECTIONS

Standard Base		Top Configuration	Volts	Phase
	EV24S-4FP208	4 French Plates	208	1 / 3
	EV24S-4FP240	4 French Plates	240	1 / 3
	EV24S-4FP480	4 French Plates	480	1 / 3
	EV24S-2HT208	2 Hot Tops	208	1 / 3
	EV24S-2HT240	2 Hot Tops	240	1 / 3
	EV24S-2HT480	2 Hot Tops	480	1 / 3

Ovens accept full-size sheet pans.



EV24S-4FP

Pictures shown are for illustration purpose only. Actual product may vary.

EV SERIES | 36" French Plates, Hot Tops & Griddle Tops

36" ELECTRIC RANGE WITH 1 OVEN FRENCH PLATE, HOT TOP OR GRIDDLE SECTIONS

Standard Base		Top Configuration	Volts	Phase	
	EV36S-36G208		36" Griddle	208	1 / 3
	EV36S-36G240		36" Griddle	240	1 / 3
	EV36S-36G480		36" Griddle	480	1 / 3
	EV36S-2FP24G208		2 French Plates & 24" Griddle right	208	1 / 3
	EV36S-2FP24G240		2 French Plates & 24" Griddle right	240	1 / 3
	EV36S-2FP24G480		2 French Plates & 24" Griddle right	480	1 / 3
	EV36S-6FP208		6 French Plates	208	1 / 3
	EV36S-6FP240		6 French Plates	240	1 / 3
	EV36S-6FP480		6 French Plates	480	1 / 3
	EV36S-3HT208		3 Hot Tops	208	1 / 3
	EV36S-3HT240		3 Hot Tops	240	1 / 3
	EV36S-3HT480		3 Hot Tops	480	1 / 3
	EV36S-4FP1HT208		4 French Plates & 1 Hot Top	208	1 / 3
	EV36S-4FP1HT240		4 French Plates & 1 Hot Top	240	1 / 3
	EV36S-4FP1HT480		4 French Plates & 1 Hot Top	480	1 / 3
	EV36S-2FP2HT208		2 French Plates & 2 Hot Tops	208	1 / 3
	EV36S-2FP2HT240		2 French Plates & 2 Hot Tops	240	1 / 3
	EV36S-2FP2HT480		2 French Plates & 2 Hot Tops	480	1 / 3
	EV36S-4FP12G208		4 French Plates & 12" Griddle right	208	1 / 3
	EV36S-4FP12G240		4 French Plates & 12" Griddle right	240	1 / 3
	EV36S-4FP12G480		4 French Plates & 12" Griddle right	480	1 / 3
	EV36S-2HT12G208		2 Hot Tops & 12" Griddle right	208	1 / 3
	EV36S-2HT12G240		2 Hot Tops & 12" Griddle right	240	1 / 3
	EV36S-2HT12G480		2 Hot Tops & 12" Griddle right	480	1 / 3

Ovens accept full-size sheet pans.



EV36S-36G
Shown on optional casters



EV36S-6FP
Shown on optional casters



EV36S-3HT
Shown on optional casters

Pictures shown are for illustration purpose only. Actual product may vary.

EV SERIES | 48" French Plates, Hot Tops & Griddle Tops

48" ELECTRIC RANGE WITH 1 OR 2 OVENS FRENCH PLATE, HOT TOP OR GRIDDLE SECTIONS

Standard Base		Top Configuration	Volts	Phase
	EV48S-8FP208		208	1 / 3
	EV48S-8FP240		240	1 / 3
	EV48S-8FP480		480	1 / 3
	EV48S-4HT208		208	1 / 3
	EV48S-4HT240		240	1 / 3
	EV48S-4HT480		480	1 / 3
2 Standard Bases				
	EV48SS-8FP208		208	1 / 3
	EV48SS-8FP240		240	1 / 3
	EV48SS-8FP480		480	1 / 3
Standard Base				
	EV48S-4FP24G208		208	1 / 3
	EV48S-4FP24G240		240	1 / 3
	EV48S-4FP24G480		480	1 / 3

Ovens accept full-size sheet pans.

*Thermostatic Griddle



EV48S-8FP

Pictures shown are for illustration purpose only. Actual product may vary.

EV SERIES | 60" French Plates, Hot Tops & Griddle Tops

60" ELECTRIC RANGE WITH 2 OVENS

FRENCH PLATES, HOT TOPS & FRENCH PLATES WITH GRIDDLE

2 Standard Bases			Top Configuration	Volts	Phase
	EV60SS-10FP208		10 French Plates	208	1 / 3
	EV60SS-10FP240		10 French Plates	240	1 / 3
	EV60SS-10FP480		10 French Plates	480	1 / 3
	EV60SS-5HT208		5 Hot Tops	208	1 / 3
	EV60SS-5HT240		5 Hot Tops	240	1 / 3
	EV60SS-5HT480		5 Hot Tops	480	1 / 3
	EV60SS-6FP24G208		6 French Plates & 24" Griddle* right	208	1 / 3
	EV60SS-6FP24G240		6 French Plates & 24" Griddle* right	240	1 / 3
	EV60SS-6FP24G480		6 French Plates & 24" Griddle* right	480	1 / 3

Ovens accept full-size sheet pans.

*Thermostatic Griddle



EV60SS-10FP

Pictures shown are for illustration purpose only. Actual product may vary.

EV SERIES | *Field-Installed Accessories*

	DESCRIPTION	ITEM #	FOR
	FRYER SHIELD Stainless steel fryer shield to protect from grease splatters	SHIELD-FRYLH SHIELD-FRYRH	All size ranges All size ranges
	EXTRA OVEN RACK Extra oven rack with guides	OVNRACK-XL20 OVNRACK-XL26	24", 48", 60" range 36", 48" 60", 72" range
	STUB RISER 4" Stainless steel backguard flue riser, 4" stub back	STUB4-XL24 STUB4-XL36 STUB4-XL48 STUB4-XL60 STUB4-XL72	24" range 36" range 48" range 60" range 72" range
	STUB RISER 10" Stainless steel backguard flue riser, 10" stub back	STUB10-XL24 STUB10-XL36 STUB10-XL48 STUB10-XL60 STUB10-XL72	24" range 36" range 48" range 60" range 72" range
	TOWEL BAR Stainless steel bar allows for conveniently hanging towels, oven mitts or other kitchen items	RCTWLBR-24 RCTWLBR-36 RCTWLBR-48 RCTWLBR-60 RCTWLBR-72	24" range 36" range 48" range 60" range 72" range
	CONDIMENT RAIL Stainless steel rail allows for convenient housing of frequently used condiments	RCCONRL-24 RCCONRL-36 RCCONRL-48 RCCONRL-60 RCCONRL-72	24" range 36" range 48" range 60" range 72" range
	REINFORCED HIGH SHELF Multi-functional stainless steel shelf to mount a salamander or cheesemelter above the range, or for extra storage space for frequently used items	RSHELF-XL24 RSHELF-XL36 RSHELF-XL48 RSHELF-XL60 RSHELF-XL72	24" range 36" range 48" range 60" range 72" range

EV SERIES | *Field-Installed Accessories & Factory-Installed Options*



DESCRIPTION

CASTERS
Set of 4 casters, 6" high
(2 locking)

ITEM

CASTERS-RR4

FOR

All size ranges.
2 sets required on
48" and larger units



ADJUSTABLE CASTERS
Set of 4 adjustable casters,
6" high (2 locking)

CASTERS-ADJRR4

All size ranges.
2 sets required on
48" and larger units



FLANGED FEET
Set of 4 stainless steel adjustable
flanged feet, 6-7½" high

VFLANGD-FEET/4

All size ranges.
2 sets required on
48" and larger units



MARINE PACKAGE
Includes sea rails, oven lock,
crumb tray lock, and flanged feet

MARINE-EV24

24", 48" & 60" range

MARINE-EV36

36", 48" 60", 72" range

FACTORY-INSTALLED OPTION

Option	Description
VOLT CONVERSION	380/415 Volt Conversion

ACHIEVER VHP SERIES | Great for Small Spaces with Heavy Workloads

STANDARD FEATURES:

- Cast iron 30,000 BTU/hr* 2-piece lift-off burners offer superior heat distribution for heavy sauté applications.
- 4" heavy duty adjustable legs.
- 1 protected standing pilot for every 2 burners** reduces gas consumption and protects against spillover.
- Heavy duty cast iron top grates, 1 per burner, support heavy pans and stockpots.
- Step Up Series configurations are available in all sizes, and features a 4" elevated rear set-up burner.

*27,500 BTU/hr for propane gas. **Individual pilot per burner section on the VHP Step Up Series.

ACHIEVER VHP SERIES

Model	Number of Burners	Total BTU/hr	Width	Depth	Overall Height	Cooking Height
VHP212	2	60,000	12"	31 $\frac{3}{8}$ "	16 $\frac{5}{8}$ "	12"
VHP424	4	120,000	24"	31 $\frac{3}{8}$ "	16 $\frac{5}{8}$ "	12"
VHP636	6	180,000	36"	31 $\frac{3}{8}$ "	16 $\frac{5}{8}$ "	12"
VHP848	8	240,000	48"	31 $\frac{3}{8}$ "	16 $\frac{5}{8}$ "	12"

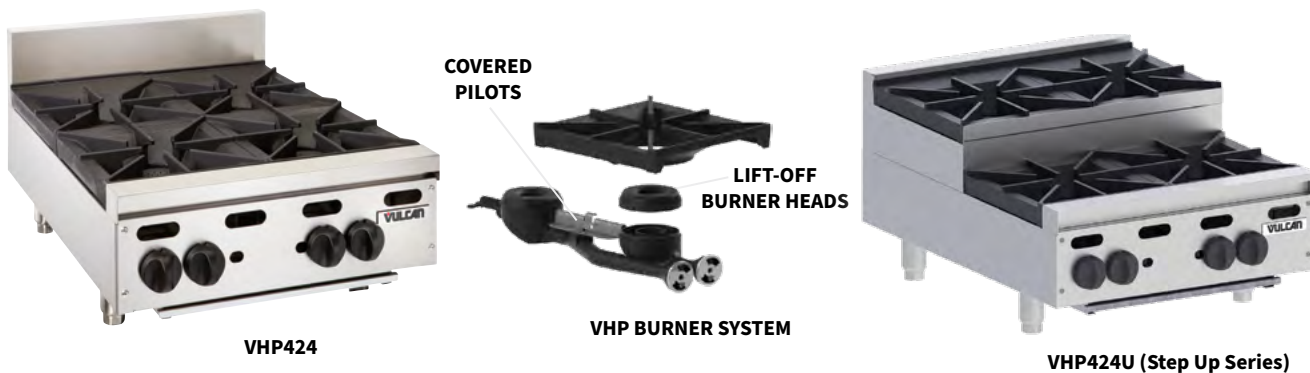

ACHIEVER VHP STEP UP SERIES

Model	Number of Burners	Total BTU/hr	Width	Depth	Overall Height	Cooking Height
VHP212U	2	60,000	12"	31 $\frac{3}{8}$ "	16 $\frac{5}{8}$ "	16"
VHP424U	4	120,000	24"	31 $\frac{3}{8}$ "	16 $\frac{5}{8}$ "	16"
VHP636U	6	180,000	36"	31 $\frac{3}{8}$ "	16 $\frac{5}{8}$ "	16"
VHP848U	8	240,000	48"	31 $\frac{3}{8}$ "	16 $\frac{5}{8}$ "	16"

ACHIEVER VHP SERIES | *Field-Installed Accessories*

	DESCRIPTION	ITEM #	FOR
	STAND Stainless steel stand with marine edge casters	STAND/C-24 STAND/C-36 STAND/C-48	VHP424, VHP424U VHP636, VHP636U VHP848, VHP848U
	PLATE RAIL Stainless steel plate rail, 10 5/8" depth	PLTRAIL-24 PLTRAIL-36 PLTRAIL-48	VHP424, VHP424U VHP636, VHP636U VHP848, VHP848U
	CONDIMENT RAIL Stainless steel condiment rail, 10 5/8" depth; pans not included	CONRAIL-24 Capacity: (3) 1/6 Pans or (1) 1/3 Pan CONRAIL-36 Capacity: (5) 1/6 Pans or (2) 1/3 Pans CONRAIL-48 Capacity: (7) 1/6 Pans or (3) 1/3 Pans	VHP424, VHP424U VHP636, VHP636U VHP848, VHP848U
	CUTTING BOARD Stainless steel cutting board with Sani-Tuff®, 10 5/8" depth <i>(Sani-Tuff® is a resilient material resistant to cracking, splintering, and absorption of liquids)</i>	CUTBD-24 CUTBD-36 CUTBD-48	VHP424, VHP424U VHP636, VHP636U VHP848, VHP848U
	6" LEGS 6" stainless steel legs	LEGS-GRD6	All VHP

STOCK POT RANGES - GAS

VSP SERIES | *Perfect for the Kitchen with a One-Pot Specialty*

STANDARD FEATURES:

- 2 high-powered 55,000 BTU/hr ring-type burners* in each section—110,000 BTU/hr input per section**.
- Standing pilot ignition with 2 infinite control manual gas valves for each section.
- Heat shield protects gas valves from high temperature, extending valve component life.
- Heavy duty cast iron top grates support large stock pots.
- Stainless steel front and sides with nickel plated legs standard.

*45,000 BTU/hr per ring for propane. **90,000 BTU/hr input per section for propane.



VSP100



VSP200F

VSP SERIES

Model	Width	Depth	Overall Height	Total BTU/hr
VSP100	18"	24½"	22½" to 24"	110,000
VSP200F	18"	49"	22½" to 24"	220,000

- Models are constructed standard for natural gas service; propane conversion kit is supplied with the unit. Conversion is the customer's responsibility. Please indicate propane or natural gas while processing your order.
- Elevation orifice kit is available free of charge for high-elevation applications. Installation is the customer's responsibility. Please indicate elevation while processing your order.

V SERIES | *Versatile & Dependable, our Commercial Ranges are Built for Operations of all sizes***STANDARD FEATURES:**

- Stainless steel front, crumb tray, front-top ledge, base, and stub back.
- 1¼" front gas manifold.
- 1¼" rear gas connection.
- 4" stainless steel stub riser.
- Heavy duty cast grates and aeration bowls.
- 6" adjustable legs.
- 4" flanged feet for all modular top units.
- Stainless steel cabinet base doors and adjustable universal slides with stainless steel shelf for cabinet base models (no shelf or slides in 12" wide cabinet bases).
- Porcelain over steel oven cavity.
- Griddles available left or right.

**OPTIONS**

- Stainless steel oven cavity
- 650°F Chef's finishing oven (standard ovens only)
- Curb mounting
- S-Grates

ACCESSORIES

- Natural or propane gas regulators
- Standard casters or adjustable casters
- Common front-top ledges
- 22" or 34" high back risers with no shelf
- 22" single and 34" double deck risers with solid or flow-thru shelves
- Dolly frames

V SERIES | 6" & 12" Wide - Top Sections

All V Series Heavy Duty Ranges are Fully Customizable to Suit Your Needs.

6" WIDE - TOP SECTIONS WORK-TOP

Model	Base	Top Configuration	Top View	Total BTU/hr
VWT06	Modular	Work-Top		N/A
VWT06B	Spreader*	Work-Top		N/A

*6" spreaders are not for sale as individual units and does not have a cabinet compartment. They must be battered with another unit. Cabinet base models have only 2 legs.

12" WIDE - TOP SECTIONS 2 BURNERS, SINGLE HOT TOP & WORK-TOP

Model	Base	Top Configuration	Top View	Total BTU/hr
V2B12	Modular	2 Burners		70,000
V2B12B	Cabinet	2 Burners		70,000
V112H	Modular	Single Hot Top		30,000
V112HB	Cabinet	Single Hot Top		30,000
VWT12	Modular	Work-Top		N/A
VWT12B	Cabinet	Work-Top		N/A
VGT12*	12" Modular Thermostatic Griddle Section			30,000
VGT12B*	12" Cabinet Base Thermostatic Griddle Section			30,000
VGM12*	12" Modular Manual Griddle Section			30,000
VGM12B*	12" Cabinet Base Manual Griddle Section			30,000

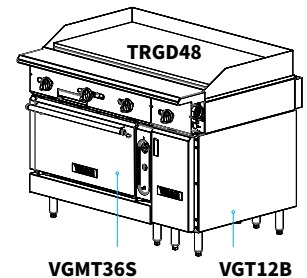
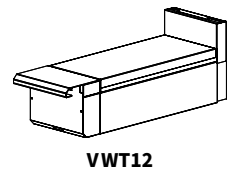
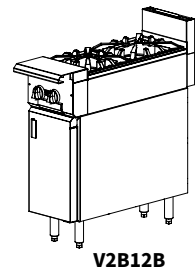

*For use with 48" overlapping griddle only.

V SERIES | 18" Wide - Top Sections

18" WIDE - TOP SECTIONS

2 BURNERS, SINGLE HOT TOPS, SINGLE FRENCH-TOPS, GRIDDLES, WORK-TOPS, CHARBROILERS & PLANCHAS

Model	Base	Top Configuration	Top View	Total BTU/hr
V2B18	Modular	2 Burners		70,000
V2B18B	Cabinet	2 Burners		70,000
V118H	Modular	Single Hot Top		30,000
V118HB	Cabinet	Single Hot Top		30,000
V1FT18	Modular	Single French-Top		25,000
V1FT18B	Cabinet	Single French-Top		25,000
VGM18	Modular	Manual Griddle		30,000
VGM18B	Cabinet	Manual Griddle		30,000
VGT18	Modular	Thermostatic Griddle		30,000
VGT18B	Cabinet	Thermostatic Griddle		30,000
VWT18	Modular	Work-Top		N/A
VWT18B	Cabinet	Work-Top		N/A
VCBB18	Modular	Charbroiler ¹		49,000
VCBB18B	Cabinet	Charbroiler ¹		49,000
V1P18	Modular	18" Plancha		17,500
V1P18B	Cabinet	18" Plancha		17,500



V1P18B

- ¹Supplied with side splashers and removable back splash.
- Manual griddle controls allow user to adjust temperature by turning the knob to adjust flame.
- Thermostatic griddle controls allow user to set and maintain a specific temperature.

See page 43 for optional flame safety device for open-top burners.

V SERIES | 24" Wide - Top Sections

24" WIDE - TOP SECTIONS

4 BURNERS, 2 HOT TOPS, GRIDDLES, CHARBROILERS & WORK-TOPS

Model	Base	Top View	Top Configuration	Total BTU/hr
V4B24	Modular		4 Burners	140,000
V4B24B	Cabinet		4 Burners	140,000
V224H	Modular		2 Hot Tops	60,000
V224HB	Cabinet		2 Hot Tops	60,000
VGM24	Modular		Manual Griddle ¹	60,000
VGM24B	Cabinet		Manual Griddle ¹	60,000
VGT24	Modular		Thermostatic Griddle ¹	60,000
VGT24B	Cabinet		Thermostatic Griddle ¹	60,000
VCBB24	Modular		Charbroiler ²	65,000
VCBB24B	Cabinet		Charbroiler ²	65,000
VTC24	Modular		VTEC Charbroiler	44,000
VTC24B	Cabinet		VTEC Charbroiler	44,000
VWT24	Modular		Work-Top	N/A
VWT24B	Cabinet		Work-Top	N/A

- ¹Rapid Recovery™ Composite Plate Griddle options available.
- ²Supplied with side splashes and removable back splash.
- Manual griddle controls allow user to adjust temperature by turning the knob to adjust flame.
- Thermostatic griddle controls allow user to set and maintain a specific temperature.

See page 43 for optional flame safety device for open-top burners.

V SERIES | 36" Wide - Top Sections

36" WIDE - TOP SECTIONS

4 OR 6 BURNERS, 3 HOT TOPS & GRIDDLES

Model	Base	Top View	Top Configuration	Total BTU/hr
V4B36	Modular		4 Burners	140,000
V4B36B	Cabinet		4 Burners	140,000
V4B36S	Standard		4 Burners	190,000
V4B36C	Convection		4 Burners	172,000
V6B36	Modular		6 Burners	210,000
V6B36B	Cabinet		6 Burners	210,000
V6B36S	Standard		6 Burners	260,000
V6B36C	Convection		6 Burners	242,000
V336H	Modular		3 Hot Tops	90,000
V336HB	Cabinet		3 Hot Tops	90,000
V336HS	Standard		3 Hot Tops	140,000
V336HC	Convection		3 Hot Tops	122,000
V2BG24	Modular		2 Burners & 24" Manual Griddle ¹	130,000
V2BG24B	Cabinet		2 Burners & 24" Manual Griddle ¹	130,000
V2BG24S	Standard		2 Burners & 24" Manual Griddle ¹	180,000
V2BG24C	Convection		2 Burners & 24" Manual Griddle ¹	162,000
V2BG4T	Modular		2 Burners & 24" Thermostatic Griddle ¹	130,000
V2BG4TB	Cabinet		2 Burners & 24" Thermostatic Griddle ¹	130,000
V2BG4TS	Standard		2 Burners & 24" Thermostatic Griddle ¹	180,000
V2BG4TC	Convection		2 Burners & 24" Thermostatic Griddle ¹	162,000

¹ Rapid Recovery™ Composite Plate Griddle options available.

See page 43 for optional flame safety device for open-top burners.

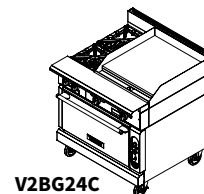
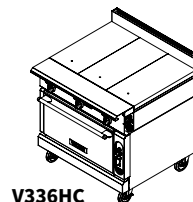

V SERIES | 36" Wide - Top Sections

36" WIDE - TOP SECTIONS

2 HOT TOPS, 2 BURNERS + GRIDDLE, DUAL FRENCH-TOP & DUAL PLANCHA

Model	Base	Top View	Top Configuration	Total BTU/hr
V236H	Modular		2 Hot Tops	60,000
V236HB	Cabinet		2 Hot Tops	60,000
V236HS	Standard		2 Hot Tops	110,000
V236HC	Convection		2 Hot Tops	92,000
V2BG18	Modular		2 Burners & 18" Manual Griddle ¹	92,000
V2BG18B	Cabinet		2 Burners & 18" Manual Griddle ¹	100,000
V2BG18S	Standard		2 Burners & 18" Manual Griddle ¹	100,000
V2BG18C	Convection		2 Burners & 18" Manual Griddle ¹	150,000
V2BG8T	Modular		2 Burners & 18" Thermostatic Griddle ¹	100,000
V2BG8TB	Cabinet		2 Burners & 18" Thermostatic Griddle ¹	100,000
V2BG8TS	Standard		2 Burners & 18" Thermostatic Griddle ¹	150,000
V2BG8TC	Convection		2 Burners & 18" Thermostatic Griddle ¹	132,000
V2FT36	Modular		Dual French-Top	50,000
V2FT36B	Cabinet		Dual French-Top	50,000
V2FT36S	Standard		Dual French-Top	100,000
V2FT36C	Convection		Dual French-Top	82,000
V2P36	Modular		Dual 18" Plancha	35,000
V2P36B	Cabinet		Dual 18" Plancha	35,000
V2P36S	Standard		Dual 18" Plancha	85,000
V2P36C	Convection		Dual 18" Plancha	67,000

- ¹Rapid Recovery™ Composite Plate Griddle options available.
- Manual griddle controls allow user to adjust temperature by turning the knob to adjust flame.
- Thermostatic griddle controls allow user to set and maintain a specific temperature.

See page 43 for optional flame safety device for open-top burners.

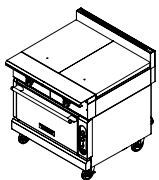

V236HC

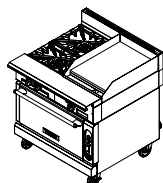

V2BG18C

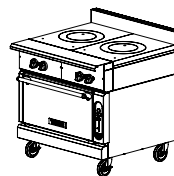

V2FT36C

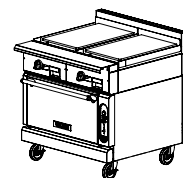

V2P36C

V SERIES | 36" & 48" Wide - Top Sections

36" WIDE - TOP SECTIONS

SINGLE FRENCH-TOP, GRIDDLES, CHARBROILERS & WORK-TOP

Model	Base	Top View	Top Configuration	Total BTU/hr
V1FT36	Modular		Single French-Top	45,000
V1FT36B	Cabinet		Single French-Top	45,000
V1FT36S	Standard		Single French-Top	95,000
V1FT36C	Convection		Single French-Top	77,000
VGM36	Modular		Manual Griddle	90,000
VGM36B	Cabinet		Manual Griddle	90,000
VGM36S	Standard		Manual Griddle	140,000
VGM36C	Convection		Manual Griddle	122,000
VGMT36	Modular		Thermostatic Griddle ¹	90,000
VGMT36B	Cabinet		Thermostatic Griddle ¹	90,000
VGMT36S	Standard		Thermostatic Griddle ¹	140,000
VGMT36C	Convection		Thermostatic Griddle ¹	122,000
VCBB36	Modular		Charbroiler ²	99,000
VCBB36B	Cabinet		Charbroiler ²	99,000
VCBB36S	Standard		Charbroiler ²	149,000
VCBB36C	Convection		Charbroiler ²	131,000
VTC36	Modular		VTEC Charbroiler	66,000
VTC36B	Cabinet		VTEC Charbroiler	66,000
VTC36S	Standard		VTEC Charbroiler	116,000
VTC36C	Convection		VTEC Charbroiler	98,000
VWT36	Modular		Work-Top	N/A
VWT36B	Cabinet		Work-Top	N/A
VWT36S	Standard		Work-Top	50,000
VWT36C	Convection		Work-Top	32,000

48" WIDE - TOP SECTION - CHARBROILER

VCBB48	Modular		Charbroiler ²	130,000
--------	---------	--	--------------------------	---------

- ¹Rapid Recovery™ Composite Plate Griddle options available.
- ²Supplied with side splashers and removable back splash.

V SERIES | Matched Fryers and Accessories

POWERFRY™ SERIES

Model	Description	Total BTU/hr
VFRY18F	18" Single Fryer with Filter	70,000
VFRY18	18" Single Fryer	70,000
VFDUMP	18" Dump Station	N/A

VFRY18F and VFRY18 have a total oil capacity of 50 lbs.

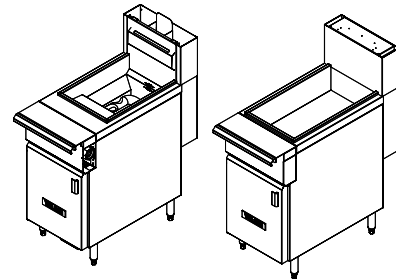

VFRY18

VFDUMP

	DESCRIPTION	ITEM #	FOR
	ADJUSTABLE CASTERS		
	Set of 4 adjustable casters	CASTERS-VULSCR	Fryer
	Set of 4 adjustable casters	CASTERS-PLTMNT	Dump station
	FRYER TANK COVER		
	Stainless steel tank cover/ work surface top	COVER-TANK	Fryer
	BULK FRYER BASKET		
	Single, bulk fryer basket	VBASKET-SINGLE	Fryer
	CRUMB SCREEN		
	Crumb screen mesh with handles	CRUMB-SCREEN	Fryer

V SERIES | Field-Installed Accessories for Matched Fryers

DESCRIPTION

ITEM

FOR



IMAGES NOT AVAILABLE

FRYER RISERS

18" W x 22" H fryer riser w/basket hanger	VFR122B	Fryer
18" W x 34" H fryer riser w/basket hanger	VFR134B	Fryer
18" W x 22" H fryer riser	VFR122D	Dump station
18" W x 34" H fryer riser	VFR134D	Dump station
18" W x 22" H fryer riser	VFR122H	Dump station with heat lamp
18" W x 34" H fryer riser	VFR134H	Dump station with heat lamp

Fryer banking strip

BANKING-VFR Fryer

10" High fryer splash (1 side only)

VSPGARD-VFRY Fryer



HEAT LAMP

Heat lamp for mounting over dump station

HL1000-LAMP Dump station



MICRO FILTRATION CONVERSION KIT

Contains fabric filter envelopes, stainless steel mesh insert and clip

CONVKIT-1 Fryer



MICRO FILTRATION FILTER ENVELOPES

6 Micro-filtration fabric filter envelopes

REFILLKIT-1 Fryer

REFRIGERATED BASES | *Keep Your Cool Under Fire*

VSC - SELF-CONTAINED MODELS – USE WITH V SERIES RANGE COMPONENTS

Model	Description
VSC36	36" Self-Contained
VSC48	48" Self-Contained
VSC60	60" Self-Contained
VSC72	72" Self-Contained
VSC84	84" Self-Contained
VSC96	96" Self-Contained



VSC72

Shown with Griddle and Charbroiler Top (sold separately)

- VSC Model Refrigerated Bases are for unitized assembly with V Series range components.
- When ordering equipment to battery with units on refrigerated bases, you must order the equipment on adjustable casters or legs (no standard casters).

ARS - SELF-CONTAINED MODELS – USE WITH COUNTERTOP EQUIPMENT

Model	Description
ARS36	36" Self-Contained
ARS48	48" Self-Contained
ARS60	60" Self-Contained
ARS72	72" Self-Contained
ARS84	84" Self-Contained
ARS96	96" Self-Contained



ARS60

Shown with CEF Fryer and VCCG Griddle (sold separately)

ARS Model Refrigerated Bases come with a marine top and are for use with countertop equipment.



ARS36



ARS96 (contact factory for pricing for right hand condenser placement)

V SERIES | Bases & Accessories

BASE SELECTIONS

STANDARD, CONVECTION, SPREADER AND CABINET

Model	Description
VSO136	36" Standard Oven Base*
VCO136	36" Convection Oven Base*
VCB106	6" Spreader Base Only
VCB112	12" Cabinet Base Only
VCB118	18" Cabinet Base Only
VCB124	24" Cabinet Base Only
VCB136	36" Cabinet Base Only

- *Oven bases not available alone—must be ordered with a top section for gas connection.
- 6" Spreader base does not have a cabinet compartment.



Versatile cabinet bases.

V SERIES CABINET BASE ACCESSORIES

Item #	Description
SLIDE-UNIV	Additional Set of Universal Slides
SHELF-CAB18	18" Additional Cabinet Base Shelf
SHELF-CAB24	24" Additional Cabinet Base Shelf
SHELF-CAB36	36" Additional Cabinet Base Shelf

A purchased set of additional cabinet base shelves will also come with a set of universal slides.

V SERIES | Options & Accessories

FACTORY-INSTALLED OPTIONS

- Spark igniter with **flame safety** device for open-top burners (per 12" or 18" OTB section).
No battery options, configurations may be limited. Consult factory for options.
- 3/4" Rear gas connection (available only on 18", 24", 36" or 48" charbroilers).
- 1 1/4" Rear gas connection (N/A on 12" units with exception of work-top units).
- 650°F Oven thermostat with 1/2" steel hearth (for use with standard ovens only).
- Fan cooling package (convection ovens) V36C-TOEFAN.
- 4" Stepped-up rear burner — 12" section (flame safety N/A).
- 4" Stepped-up rear burner — 18" section (flame safety N/A).
- Custom color finish over stainless exterior panels.
- Full 12" hot top in lieu of 12" section.
- Full 18" hot top in lieu of 18" section.
- 18" wide French-top in lieu of 18" section.
- Half hot top rear—12" section.
- Half hot top rear—18" section.
- 12" Work-top in lieu of 12" section.
- 18" Work-top in lieu of 18" section.
- 24" Work-top in lieu of 24" section.
- Less legs for dolly mounting.
- Stainless steel oven cavity.
- Welded divider (available on chrome and steel plates).
- Griddle grooving (available on steel plates).
- 24" Rapid Recovery™ Composite plate griddle in lieu of 24" thermostatic griddle.
- 36" Rapid Recovery™ Composite plate griddle in lieu of 24" thermostatic griddle.

Flame safety device generates a spark to light the standing pilot



Stand out from the rest. Ask us about custom color finish options!

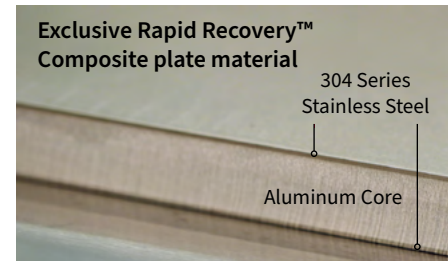

Vulcan's proprietary composite griddle plate provides faster heat-up times and uniform temperature control from corner-to-corner on the cooking surface, which means higher productivity and food quality.

CHARBROILER | FIELD-INSTALLED ACCESSORIES

Item #	Description
GRATE-WAFFLE	Cast iron waffle grate
GRATE-CDIA7	Cast iron diamond grate
GRATE-RROD7	Round rod grate
GRATE-SSDIA7	Stainless steel diamond grate
GRATE-VTFISH	Stainless steel fish grate for VTEC Charbroiler
EMITTER-VTEC	Replacement emitter panel



Cast Iron Waffle



Cast Iron Diamond



Round Rod



Diamond

V SERIES | *Field-Installed Accessories*

GENERAL

Item #	Description
GSTRIP-BODY	Oven Banking Strip
RACK-OVEN	Single Oven Rack (Standard or Convection Oven)
WRENCH-HDNEW	Union Wrench
SGRATE-VRNG	"S" Grate, 12" Section
MGRD48-MAN001	48" Manual Overlapping Griddle*
MGRD60-MAN001	60" Manual Overlapping Griddle*
MGRD72-MAN001	72" Manual Overlapping Griddle
TGRD48-TGA001	48" Thermostatic Overlapping Griddle*
TGRD60-TGA001	60" Thermostatic Overlapping Griddle*
TGRD72-TGA001	72" Thermostatic Overlapping Griddle



SGRATE-VRNG

- *36" oven on left side only.
- When ordering an overlapping griddle, you must add for a common front-top ledge and common backrisers (overlapping risers and riser accessories are located on page 46).

REGULATORS & HOSES

Item #	Description
PRREGN-3/4	3/4" Gas pressure regulator — natural
PRREGN-001	1" Gas pressure regulator — natural
PRESREG-NA11/4	1 1/4" Gas pressure regulator — natural
PRREGLP-3/4	3/4" Gas pressure regulator — propane
PRREGLP-001	1" Gas pressure regulator — propane
PRESREG-LP11/4	1 1/4" Gas pressure regulator — propane
3/4QD-HOSE-4	3/4" x 4' Gas flex hose and quick disconnect
1INFLEX-4FT	1" x 4' Gas flex hose and quick disconnect
11/4QDH-4FT	1 1/4" x 4' Gas flex hose and quick disconnect
CAP & CVR-KIT	Cap and cover kit

LEGS & CASTERS

Item #	Description
LEGSST-RR4	6" Legs for field replacement
VFLANGD-FEET/4	Set of 4 stainless steel adjustable flanged feet, 6-7 1/2" high
CASTERS-RR4	Set of 4 casters, 6" high (2 locking)
CASTERS-ADJRR4	Castors, 6" high, adjustable, set of 4 (2 with locks)
V12-TOE	3" Toe base for curb mounting—12"
V18-TOE	3" Toe base for curb mounting—18"
V24-TOE	3" Toe base for curb mounting—24"
V36-TOE	3" Toe base for curb mounting—36"
V36C-TOEFAN	3" Toe base for curb mounting—convection oven with cooling fan

V SERIES | Dolly Frames & Equipment Stands

DOLLY FRAMES & EQUIPMENT STANDS

Item #	Description
VDOLLY-36	36" Dolly Frame
VDOLLY-48	48" Dolly Frame
VDOLLY-54	54" Dolly Frame
VDOLLY-60	60" Dolly Frame
VDOLLY-72	72" Dolly Frame
VDOLLY-84	84" Dolly Frame
VDOLLY-96	96" Dolly Frame
VDOLLY-108	108" Dolly Frame

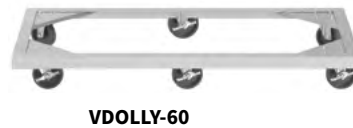

STAND/F-VCCB36	36" Wide Equipment Stand on Flanged Feet
STAND/F-HD42	42" Wide Equipment Stand on Flanged Feet
STAND/F-VCCB48	48" Wide Equipment Stand on Flanged Feet
STAND/F-HD54	54" Wide Equipment Stand on Flanged Feet
STAND/F-VCCB60	60" Wide Equipment Stand on Flanged Feet
STAND/F-VCCB72	72" Wide Equipment Stand on Flanged Feet



STAND/C-VCCB36	36" Wide Equipment Stand on Casters
STAND/C-HD42	42" Wide Equipment Stand on Casters
STAND/C-VCCB48	48" Wide Equipment Stand on Casters
STAND/C-HD54	54" Wide Equipment Stand on Casters
STAND/C-VCCB60	60" Wide Equipment Stand on Casters
STAND/C-VCCB72	72" Wide Equipment Stand on Casters



V SERIES | *Field-installed Accessories*

RISERS & RISER ACCESSORIES, NON-OVERLAPPING

Description	12"	18"	24"	36"	48"*
Reinforced Riser (Standard or Convection Oven)	N/A	N/A	V24RR	V36RR	V48RR
Stub Riser—4"	V12ST4	V18ST4	V24ST4	V36ST4	V48ST4
Single Deck Height Riser (No Shelf—22" High)	V12ST22	V18ST22	V24ST22	V36ST22	V48ST22
Double Deck Height Riser (No Shelf—34" High)	V12ST34	V18ST34	V24ST34	V36ST34	V48ST34
Single Deck Riser with Hi-Shelf (Solid Shelf—22" High)	V12SD	V18SD	V24SD	V36SD	N/A
Double Deck Riser with Hi-Shelf (2 Solid Shelves—34" High)	V12DD	V18DD	V24DD	V36DD	N/A
Single Deck Riser with Hi-Shelf (Flow-Thru Shelf—22" High)	V12SFL	V18SFL	V24SFL	V36SFL	N/A
Double Deck Riser with Hi-Shelf (2 Flow-Thru Shelves—34" High)	V12DFL	V18DFL	V24DFL	V36DFL	N/A
Section of Flow-Thru Grate	OSHELF-GRT12	OSHELF-GRT18	OSHELF-GRT24	N/A	N/A

*48RR not available on Charbroiler

RISERS & RISER ACCESSORIES, OVERLAPPING

Description	36"	48"	54"	60"	72"
4" Stub Backs	V36ST4	VOVER-48ST	VOVER-54ST	VOVER-60ST	VOVER-72ST
Single Deck Height Riser (No Shelf—22" High)	V36ST22	22RSR48	22RSR54	22RSR60	22RSR72
Double Deck Height Riser (No Shelf—34" High)	V36ST34	34RSR48	34RSR54	34RSR60	34RSR72
Single Deck Riser with Hi-Shelf (Solid Shelf—22" High)	V36SD	22SHS48	22SHS54	22SHS60	22SHS72
Double Deck Riser with Hi-Shelf (2 Solid Shelves—34" High)	V36DD	34DHS48	34DHS54	34DHS60	34DHS72
Single Deck Riser with Hi-Shelf (Flow-Thru Shelf—22" High)	V36SFL	22SFS48	22SFS54	22SFS60	22SFS72
Double Deck Riser with Hi-Shelf (2 Flow-Thru Shelves—34" High)	V36DFL	34DFS48	34DFS54	34DFS60	34DFS72
Front Top Ledge with Pull-Out Condiment Rail, Fits 1/9th Pans	FRTTOP-36CMD	FRTTOP-48CMD	FRTTOP-54CMD	FRTTOP-60CMD	FRTTOP-72CMD
Front Top Ledge, with Solid Plating Area	FRTTOP-36WLD	FRTTOP-48WLD	FRTTOP-54WLD	FRTTOP-60WLD	FRTTOP-72WLD

MOD SUITE | CUSTOM COOKLINE DESIGN SOLUTIONS



COOKLINE SOLUTIONS

MODULAR. FLEXIBLE. ADAPTABLE.

The MOD suite is Vulcan's newest custom cookline design solution. True modularity allows for impactful and profitable design, easy maintenance, and flexibility for future line changes.

Our talented and dedicated in-house design team is ready to help with your next project — from concept to completion. Revit drawings included!

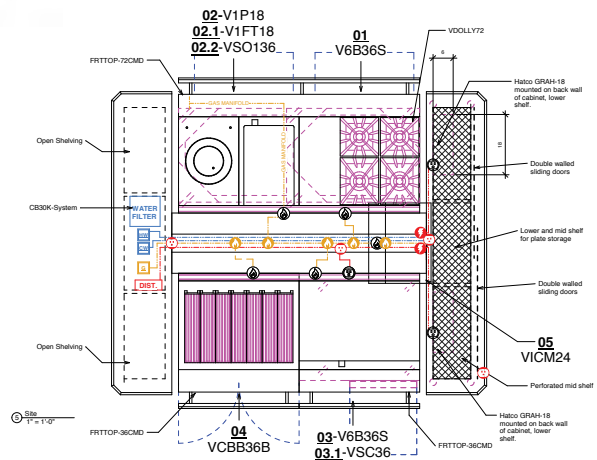

Find everything you need to spec your next project at vulcanequipment.com/consultants.

For assistance, contact our Consultant Hotline at **888-492-3895**.

CHOPHOUSE | *Make Your Menu Sizzle and Your Profits Soar*

STANDARD FEATURES:

- Stainless steel front, sides, and stand.
- Casters.
- 36"W x 34³/₁₆"D - VST3B.
- 45¹/₂"W x 34³/₁₆"D - VST4B.
- Spring balanced, 4 position grid.
- (3) 33,000 BTU/hr ceramic burners - VST3B.
- (3) 45,000 BTU/hr ceramic burners - VST4B.
- Griddle plate with 2" splash guards.
- Standard 52" high griddle cooking surface.
- Griddle/broiler brush.
- 1 1/4" diameter rear gas connection with regulator - VST3B.
- 3/4" diameter rear gas connection with regulator - VST4B.
- 1-year limited parts and labor warranty.



CHOPHOUSE MODELS

Model	Description	Total BTU/hr
VST3B	Ceramic Broiler with Griddle Plate	100,000
VST4B	Ceramic Broiler with Griddle Plate	135,000

VST3B can also be mounted on V Series HD Range oven bases or refrigerated bases.

FIELD-INSTALLED ACCESSORIES

Item #	Description
3/4QD-HOSE-4	3/4" x 4' quick disconnect hose with restraining device
1INFLEX-4FT	1" x 4' quick disconnect hose with restraining device
11/4QDH-4FT	1 1/4" x 4' quick disconnect hose with restraining device



FACTORY-INSTALLED OPTION

4" taller leg stand with casters (only available on VST4B)

MATCHED UPRIGHT | *Make Your Menu Sizzle and Your Profits Soar*

STANDARD FEATURES:

- Stainless steel front, sides, base, and finishing oven.
- Spring balanced, 5 position grid.
- (4) 25,000 BTU/hr infrared burners on infrared (IR) broiler.
- (3) 33,000 BTU/hr ceramic radiant burners on radiant broiler.
- 2 infinite heat controls.
- Full width floating stainless steel drip pan.
- 1 ¼" diameter front gas manifold.
- 1 ¼" rear gas manifold (capped).
- 25" W x 25" D cooking grid (625 sq. inches).
- Natural or propane gas pressure regulator.
- 6" adjustable stainless steel legs (4" on VBB1BF-603).

MATCHED UPRIGHT MODELS INFRARED (IR) OR CERAMIC BROILER

Standard Oven Base	Broiler Type	Total BTU/hr
 VIR1SF	Infrared	150,000
VBB1SF	Ceramic	150,000

Convection Oven Base	Broiler Type	Total BTU/hr
 VIR1CF	Infrared	132,000
VBB1CF	Ceramic	132,000

Cabinet Base	Broiler Type	Total BTU/hr
 VIR1BF	Infrared	100,000
VBB1BF	Ceramic	100,000

Modular (can be countertop or on refrigerated base*)	Broiler Type	Total BTU/hr
VIR1F	Infrared	100,000
VBB1F	Ceramic	100,000

*Must add cost of refrigerated base. Can be mounted only on Vulcan base.

FIELD-INSTALLED ACCESSORIES

Item #	Description
CASTERS-RR4	Set of 4 casters, 6" high



VIR1SF
Shown on optional casters



VBB1F
Countertop unit with standard 4" adjustable legs

FACTORY-INSTALLED OPTION

Omit Finishing Oven

DOUBLE DECK | *Make Your Menu Sizzle and Your Profits Soar*



VIR2

STANDARD FEATURES:

- Stainless steel front, sides, and base.
- Spring balanced, 5 position grid per deck.
- (4) 25,000 BTU/hr infrared burners on infrared (IR) broiler per deck.
- (3) 33,000 BTU/hr ceramic radiant burners on radiant broiler per deck.
- 25" W x 25" D cooking grid (625 sq. inches).
- 2 infinite heat controls per deck.
- Full width floating stainless steel drip pan.
- 1" rear gas manifold.
- Natural or propane gas pressure regulator.
- Set of 4 casters, 6" high.

DOUBLE DECK MODELS INFRARED (IR) AND OR CERAMIC BROILER

Model	Broiler Type (top / bottom)	Total BTU/hr
VIR2	Infrared / Infrared	200,000
VBB2	Ceramic / Ceramic	200,000
VIB2	Infrared / Ceramic	200,000
VBI2	Ceramic / Infrared	200,000

- Double Deck Broilers cannot be manifolded together with range line.
- Must be gassed independently.

FIELD-INSTALLED ACCESSORIES

Item #	Description
11/4QDH-4FT	1 ¼" x 4' quick disconnect hose with restraining device
1INFLEX-4FT	1" x 4' quick disconnect hose with restraining device



SALAMANDERS | *Quickly Melts Cheese, Browns Bread Crumbs and Finishes Meat*

STANDARD FEATURES (GAS & ELECTRIC):

- Stainless steel front, top, and sides.
- Dual temperature controls for zone cooking.
- 6 grid positions, grid measures 27½" W x 13" D.
- Removable full-width spillage pan.



36RB-N

GAS MODELS:

- ¾" Gas rear connection and pressure regulator.

GAS SALAMANDER BROILER | INFRARED (IR) OR RADIANT

Model	Width	Burners	Gas	Total BTU/hr	Mounting
INFRARED (IR)					
36IRB-N	36"	1	Natural	30,000	Counter, Range, or Wall
36IRB-P	36"	1	Propane	30,000	Counter, Range, or Wall
RADIANT					
36RB-N	36"	6	Natural	50,000	Counter, Range, or Wall
36RB-P	36"	6	Propane	50,000	Counter, Range, or Wall

ELECTRIC MODELS:

- Available on any 36" electric range with standard oven.
- (2) 2,250 watt heating elements for cooking zone control.
- Standard voltage 208V or 240V field convertible to 1 Phase.









36ESB

ELECTRIC SALAMANDER BROILER

Model	Width	Volts	Phase	Mounting
36ESB-208	36"	208	1/3	Counter, Range, or Wall
36ESB-240	36"	240	1/3	Counter, Range, or Wall
36ESB-480	36"	480	1/3	Counter, Range, or Wall

SALAMANDER | *Field-installed Accessories*

	DESCRIPTION	ITEM #	FOR
	WALL MOUNT BRACKET 2 stainless steel brackets to install salamander to wall <i>BOTTOM-SLMNDR is required to install on wall</i>	WALLMNT-CHRBKR	All sizes
	BOTTOM PANEL Stainless steel bottom panel covers bottom of salamander <i>Required with wall bracket</i>	BOTTOM-SLMNDR	All sizes
	BACK PANEL Stainless steel back panel	BACK-SLMNDR	All sizes
	SET OF LEGS 4" High adjustable legs for counter	COUNTER-ADJLEG	All sizes
	REINFORCED HIGH SHELF Shelf and mounting brackets to add Salamander/Cheesemelter to Endurance™ Series Range <i>Not compatible with V-Series Ranges.</i>	RSHELF-XL24 RSHELF-XL36 RSHELF-XL48 RSHELF-XL60 RSHELF-XL72	24" Endurance™ range 36" Endurance™ range 48" Endurance™ range 60" Endurance™ range 72" Endurance™ range
 IMAGE NOT AVAILABLE	REINFORCED RISER Mount a Salamander/Cheesemelter on a back riser above the V Series Heavy Duty Range <i>Required if mounting above a V Series Range. Not compatible with Endurance™ Series Ranges.</i>	V24RR V36RR V48RR	24" V Series range 36" V Series range 48" V Series range
	INTER-PLUMB KIT Inter-Plumb kit for connecting Salamander/Cheesemelter	CONNECT-CHALL PLUMBIN-KIT	Endurance™ Series Range V Series Range

Ranges with elevated salamander broilers should not be mounted on casters.

GAS & ELECTRIC CHEESEMELTERS | *Finish dishes to perfection*



VICM36

STANDARD FEATURES (GAS MODELS):

- Energy-efficient gas infrared burners.
- 3-position heavy duty rack guides and wire chrome grid rack.
- 21" H x 19" D with all stainless steel interior.
- Removable full-width stainless steel spillage pan for easy cleaning and maintenance.
- Factory installed wall mount bracket for installation on range shelf or legs.

GAS-INFRARED

Model	Burners	Total BTU/hr	Width	Depth	Overall Height
VICM24	1	20,000	24"	19"	21"
VICM36	1	30,000	36"	19"	21"
VICM48	2	40,000	48"	19"	21"
VICM60	2	50,000	60"	19"	21"
VICM72	2	60,000	72"	19"	21"

- Models are constructed standard for natural gas service; propane conversion kit is supplied with the unit. Conversion is the customer's responsibility. Please indicate propane or natural gas while processing your order.
- Elevation orifice kit is available free of charge for high-elevation applications. Installation is the customer's responsibility. Please indicate elevation while processing your order.

ACCESSORY

4" High adjustable legs for counter installation



COUNTER-ADJLEG
All VICM



1036

STANDARD FEATURES (ELECTRIC MODELS):

- Stainless steel body construction.
- Solid state controls.
- Rack-activated quartz heaters to conserve energy.
- 4-position rack locator.
- Energy-saving standby mode.
- 208 or 240V, 1 Phase electrical connection required.
- Mounting kit (panel and legs) for wall or counter mounting.

ELECTRIC

Model	Total kW	Width	Depth	Overall Height Countertop Model	Overall Height Wall-Mounted Model
1024	2.4	27"	17 $\frac{1}{8}$ "	19 $\frac{1}{4}$ "	15 $\frac{1}{4}$ "
1036	3.6	36 $\frac{1}{2}$ "	17 $\frac{1}{8}$ "	19 $\frac{1}{4}$ "	15 $\frac{1}{4}$ "
1048	4.8	50"	17 $\frac{1}{8}$ "	19 $\frac{1}{4}$ "	15 $\frac{1}{4}$ "

VC & SG SERIES | An Improved Full Line to Meet Every Convection Oven Need

VC4 Series
Foodservice Workhorse



VC5 Series
Removable Doors



VC6 Series
Deeper Cavity



SG Series
More Horsepower



FEATURES / SPECS	VC4 / VC44	VC5 / VC55	VC6 / VC66	SG4 / SG44
ENERGY STAR® certified				
Removable doors	N/A	✓	N/A	N/A
Gentle Bake Mode for more delicate heat	N/A	Standard on VC5E	N/A	✓
Rack guide positions	11	11	11	11
Grab-and-go oven racks	✓	✓	✓	✓
Cool to the touch door handle	✓	✓	✓	✓
Oven cool switch for rapid cool down	✓	✓	✓	✓
Controls available	Solid State (D) or Computer (C)	Solid State (D) With Enhanced LED Display	Solid State (D) or Computer (C)	Solid State (D)

CONTROL SYSTEM OPTIONS FOR VC4 & VC6 SERIES



SOLID STATE (D) CONTROLS

VC4 & VC6 Series only

- Adjusts from 150–500°F, providing instant response to variations in oven temperature for more consistent cooking
- 60-minute timer with audible alarm
- Easy-to-read time and temperature settings



COMPUTER (C) CONTROLS

VC4 & VC6 Series only

- Programmable time and temperature
- Digital time and temperature readout
- Programmable Roast & Hold setting
- USB interface for software and menu updates
- Shelf timing capability for up to 5 shelves

CONVECTION OVENS - FULL SIZE



VC4 SERIES | GAS & ELECTRIC *All-Purpose Ovens Save Operating Costs*

With gentle air circulation and even heat distribution, these versatile ovens deliver delicious, evenly cooked casseroles, meats, vegetables, and baked goods.



VC4GD
Shown with OPNSTND-KIT and CSTSET-SINGLE. Pan not included.

STANDARD FEATURES:

- Standard cavity depth.
- Painted legs with bullet feet.
- 50,000 BTU/hr burner per oven section.
- Electronic spark ignition.
- 3/4" rear gas connection.
- Internal combination gas pressure regulator and safety solenoid system.
- 1-Piece cool-to-the-touch door handles.
- 5 Grab-and-go oven racks with 11 rack positions.
- 1/2 HP 2-speed oven blower motor; 115V, 60 Hz, 1 Phase with 6' cord and plug.
- Oven cool switch for rapid cool down.
- Porcelain enamel on steel oven interior.
- Stainless steel front, sides, and top.
- Stainless steel doors with double pane windows.
- Stackable.
- ENERGY STAR® certified.

VC4 CONVECTION OVENS

Model	Control Type	Sections	Description	Input
GAS				
VC4GD	Solid State	1	Single Deck on Adjustable 23 ³ / ₄ " Legs*	50,000 BTU/hr
VC4GC	Computer	1	Single Deck on Adjustable 23 ³ / ₄ " Legs*	50,000 BTU/hr
VC44GD	Solid State	2	Double Deck on 8" Legs	100,000 BTU/hr
VC44GG	Computer	2	Double Deck on 8" Legs	100,000 BTU/hr
ELECTRIC				
VC4ED	Solid State	1	Single Deck on Adjustable 23 ³ / ₄ " Legs*	12.5 kW
VC4EC	Computer	1	Single Deck on Adjustable 23 ³ / ₄ " Legs*	12.5 kW
VC44ED	Solid State	2	Double Deck on 8" Legs	25 kW
VC44EC	Computer	2	Double Deck on 8" Legs	25 kW



	Oven Cavity Dimensions (W x D x H)	Exterior Dimensions (W x D x H)	Standard Power Supply Motor size (gas units)
VC4G	29" x 22 ¹ / ₈ " x 20"	40 ¹ / ₄ " x 41 ¹ / ₈ " x 54 ³ / ₄ "	1/2 HP, 115V, 8 Amps
VC44G	29" x 22 ¹ / ₈ " x 20"	40 ¹ / ₄ " x 41 ¹ / ₈ " x 70"	(2) 1/2 HP, 115V, 8 Amps
VC4E	29" x 22 ¹ / ₈ " x 20"	40 ¹ / ₄ " x 41 ¹ / ₈ " x 54 ³ / ₄ "	208/240V, 60 Hz, 1 or 3 Phase
VC44E	29" x 22 ¹ / ₈ " x 20"	40 ¹ / ₄ " x 41 ¹ / ₈ " x 70"	208/240V, 60 Hz, 1 or 3 Phase

**23³/₄" legs can adjust an additional 1" in length. Legs with casters are adjustable from 28" to 29¹/₈" in length.
All ovens can be double stacked.*



VC5 SERIES | GAS & ELECTRIC *All-Purpose Ovens. One-Of-A-Kind Features.*

Vulcan's VC5 Series delivers high-quality results and standout features, including removable, dishwasher-safe doors and easy-to-use controls with LED display.



STANDARD FEATURES:

- Removable dishwasher-safe doors.
- Standard cavity depth.
- Painted legs with bullet feet.
- 50,000 BTU/hr (VC5G) and rear elements (VC5E) provide great bake results.
- 1-Piece cool-to-the-touch door handles.
- 5 grab-and-go oven racks with 11 rack positions.
- Mix and match—ability to stack on top of VC4 and SG4 models.
- Stackable. All ovens can be double stacked.
- Reduced outer door temperatures.
- Built-in service diagnostics.
- 3-Year warranty on doors.
- ENERGY STAR® certified.

Removable dishwasher-safe doors



VC5 CONVECTION OVENS

Model	Control Type	Sections	Description	Input
GAS				
VC5GD	Solid State	1	Single Deck on Adjustable 23¾" Legs*	50,000 BTU/hr
VC55GD	Solid State	2	Double Deck on 8" Legs	100,000 BTU/hr
ELECTRIC				
VC5ED	Solid State	1	Single Deck on Adjustable 23¾" Legs*	12.5 kW
VC55ED	Solid State	2	Double Deck on 8" Legs	25 kW

	Oven Cavity Dimensions (W x D x H)	Exterior Dimensions (W x D x H)	Standard Power Supply Motor size (gas units)
VC5GD	29" x 22⅞" x 20"	40¼" x 40" x 54¾"	½ HP, 115V, 8 Amps
VC55GD	29" x 22⅞" x 20"	40¼" x 40" x 70"	(2) ½ HP, 115V, 8 Amps
VC5ED	29" x 22⅞" x 20"	40¼" x 40" x 54¾"	208/240V, 60 Hz, 1 or 3 Phase
VC55ED	29" x 22⅞" x 20"	40¼" x 40" x 70"	208/240V, 60 Hz, 1 or 3 Phase

**23¾" legs can adjust an additional 1" in length. Legs with casters are adjustable from 28" to 29⅞" in length.*



VC6 SERIES | GAS & ELECTRIC *Deep Cavity / Bakery Depth*

Engineered for versatility, these all-purpose ovens deliver consistent and exceptional results. Gentle air circulation and even heat distribution ensure perfectly cooked dishes – from roasted chicken and baked pasta to artisan breads and pastries.

STANDARD FEATURES:

- Deep cavity depth.
- 50,000 BTU/hr burner per oven section.
- Painted legs with bullet feet.
- Electronic spark ignition.
- 3/4" rear gas connection.
- Internal combination gas pressure regulator and safety solenoid system.
- 5 grab-and-go oven racks with 11 rack positions.
- ½ HP 2-speed oven blower motor; 115V, 60 Hz, 1 Phase with 6' cord and plug.
- Oven cool switch for rapid cool down.
- Porcelain enamel on steel oven interior.
- Stainless steel front, sides, and top.
- Stainless steel doors with double pane windows.
- All ovens can be double stacked.
- ENERGY STAR® certified.



VC6
Shown with painted black legs on bullet feet

VC6 CONVECTION OVENS

Model	Control Type	Sections	Description	Input
GAS				
VC6GD	Solid State	1	Single Deck on Adjustable 23¾" Legs*	50,000 BTU/hr
VC6GC	Computer	1	Single Deck on Adjustable 23¾" Legs*	50,000 BTU/hr
VC66GD	Solid State	2	Double Deck on 8" Legs	100,000 BTU/hr
VC66GC	Computer	2	Double Deck on 8" Legs	100,000 BTU/hr
ELECTRIC				
VC6ED	Solid State	1	Single Deck on Adjustable 23¾" Legs*	12.5 kW
VC6EC	Computer	1	Single Deck on Adjustable 23¾" Legs*	12.5 kW
VC66ED	Solid State	2	Double Deck on 8" Legs	25 kW
VC66EC	Computer	2	Double Deck on 8" Legs	25 kW
	Oven Cavity Dimensions (W x D x H)		Exterior Dimensions (W x D x H)	Standard Power Supply Motor size (gas units)
VC6GD	29" x 26⅞" x 20"		40¼" x 45⅞" x 54¾"	½ HP, 115V, 8 Amps
VC66GD	29" x 26⅞" x 20"		40¼" x 45⅞" x 70"	(2) ½ HP, 115V, 8 Amps
VC6ED	29" x 26⅞" x 20"		40¼" x 45⅞" x 54¾"	208/240V, 60 Hz, 1 or 3 Phase
VC66ED	29" x 26⅞" x 20"		40¼" x 45⅞" x 70"	208/240V, 60 Hz, 1 or 3 Phase

*23¾" legs can adjust an additional 1" in length. Legs with casters are adjustable from 28" to 29⅞" in length.



SG SERIES | GAS *Optimal Balance of Recovery and Baking*

STANDARD FEATURES:

- Standard cavity depth.
- Painted legs with bullet feet.
- 60,000 BTU/hr total input.
- Gentle bake mode switch for greater flexibility.
- 5 grab-and-go oven racks with 11 rack positions.
- Independently operated doors with full-length hinge pins and welded full-door frames.
- 1-piece cool-to-the-touch door handles.
- ½ HP 2-speed fan motor.
- Stackable. Choice of single or double deck configuration.
- Single ovens include 22 1/4" black painted legs. Double deck ovens include 8" stainless steel legs.
- Stainless steel front, sides, top, and door gaskets.
- Easy-to-clean, porcelain-coated enameled steel interior.
- Auxiliary fan switch for rapid cool down.
- ¾" Gas connection with internal combination gas pressure regulator and safety solenoid system (interconnecting piping supplied on double deck models for single point gas connection).
- ENERGY STAR® certified.



SG4
Shown with LEGSET-CST/PT



SG44
Shown with optional casters

SG SERIES CONVECTION OVENS

Model	Control Type	Sections	Description	Total BTU/hr
SG4GD	Solid State	1	Single Deck on Adjustable 23¾" Legs*	60,000
SG44GD	Solid State	2	Double Deck on 8" Legs	120,000

Model	Oven Cavity Dimensions (W x D x H)	Exterior Dimensions (W x D x H)	Motor size
SG4GD	29" x 22½" x 20"	40¼" x 41½" x 54¾"	½ HP, 115V, 8 Amps
SG44GD	29" x 22½" x 20"	40¼" x 41½" x 70"	(2) ½ HP, 115V, 8 Amps

*23¾" legs can adjust an additional 1" in length. Legs with casters are adjustable from 28" to 29½" in length.
All ovens can be double stacked.

CONVECTION OVENS - HALF SIZE



GCO/ECO SERIES | Half-Size Ovens with Full-Featured Quality

Get the power and performance of a full-size Vulcan Convection Oven in the space-saving design of our GCO or ECO Series. Same great features, smaller footprint.

STANDARD FEATURES:

- Stainless steel front, top, sides, and rear enclosure panel.
- Stainless steel door with double pane window.
- 4" adjustable chrome legs.
- Porcelain enamel on steel oven interior.
- 5 oven racks.
- 60-minute timer with audible alarm.
- Available with optional right-side door hinge.
- Stackable. Choice of single or double deck configuration.
- ENERGY STAR® certified.



GCO2D



ECO2D

Shown with leg stand and casters

GCO CONVECTION OVENS

Model	Control Type	Description	Input
GAS			
GCO2D	Solid State	Single Deck Half-Size Gas Convection Oven	25,000 BTU/hr
GCO22D	Solid State	Double Deck Half-Size Gas Convection Oven	50,000 BTU/hr
ELECTRIC			
ECO2D	Solid State	Single Deck Half-Size Electric Convection Oven	5.5 kW
ECO22D	Solid State	Double Deck Half-Size Electric Convection Oven	11 kW
	Oven Cavity Dimensions (W x D x H)	Exterior Dimensions (W x D x H)	Standard Power Supply Motor size (gas units)
GCO2D	15¼" x 21" x 20"	30" x 28½" x 30⅝"	½ HP, 115V, 8 Amps
ECO2D	15¼" x 21" x 20"	30" x 28½" x 30⅝"	208/240V, 60 Hz, 1 or 3 Phase

VC / SG / ECO / GCO SERIES | *Field-Installed Accessories*

	DESCRIPTION	ITEM #	FOR
	HEAT SHIELD Heat deflector to protect unit from high temperature equipment	HTSHLD-LH/V (<i>left</i>)	VC4, VC5, VC6, & SG
		HTSHLD-RH/V (<i>right</i>)	VC4, VC5, VC6, & SG
	OVEN RACK Extra oven rack	RACK-1PCNEW	VC4, VC5, & SG
		RACK-1PCDDNEW	VC6
		RACK-HLF1PC	ECO2D & GCO2D
	RACK HANGER Use to hang spare oven racks; installs on side of oven	RACK-HANGRV	All
	STAINLESS STEEL LEG STAND Features 4 legs, adjustable feet, stainless steel shelf, and adjustable rack supports for a single deck oven	OPNSTND-LEGS/SS	VC4 & SG
		VC5-OPNSTD-LG-SS	VC5
		OPNSTND-HLFLEG	ECO2D & GCO2D
	PAINTED LEG STAND Designed to retrofit standard black painted legs, kit includes mounting brackets, stainless steel shelf, and adjustable rack supports	OPNSTND-KIT	VC4 & SG
		VC5-OPNSTD-KIT	VC5
	CASTERS Set of 4 (2 locking) casters for single deck oven or leg stand	CSTSET-SINGLE	VC4, VC5, VC6, & SG
	FEET Set of 4 flanged feet	FLNGD-FT/4	VC4, VC5, VC6, & SG
	LEGS Stainless steel legs with bullet feet	LEGSET-FT/SS	All
	LEGS Stainless steel legs with casters	LEGSET-CST/SS	All
	LEGS Painted legs with casters	LEGSET-CST/PT	All

VC / SG / ECO / GCO SERIES | *Field-Installed Accessories & Factory-Installed Options*

FIELD-INSTALLED ACCESSORIES

Item #	Description	VC4	VC5	VC6	SG	ECO	GCO
DRAFT-DIVERTER	Down draft flue diverter for direct vent connection	✓	✓	✓	✓	N/A	N/A
ELVKIT-GASOVN	Elevation kit for 44000 BTU gas ovens	✓	✓	✓	N/A	N/A	N/A
ELVKIT-GAS50KVC	Elevation kit for 50000 BTU gas ovens	Gas	Gas	Gas	N/A	N/A	N/A
ELVKIT-GAS60KSG	Elevation kit for SG Series gas ovens	N/A	N/A	N/A	✓	N/A	N/A
ELVKIT-GASHLF	Elevation kit for GCO gas ovens	N/A	N/A	N/A	N/A	N/A	✓
STACK/G-LEG	Stacking kit with legs for 2 full-size gas ovens	Gas	Gas	Gas	Gas	N/A	N/A
STACK/G-CST	Stacking kit with legs & casters for 2 full-size gas ovens	Gas	Gas	Gas	Gas	N/A	N/A
STACK/G-HLFLEG	Stacking kit with legs for 2 half-size ovens	N/A	N/A	N/A	N/A	N/A	✓
STACK/E-LEG	Stacking kit with legs for 2 full-size electric ovens	Elec.	Elec.	Elec.	N/A	N/A	N/A
STACK/E-CST	Stacking kit with legs & casters for 2 full-size electric ovens	Elec.	Elec.	Elec.	N/A	N/A	N/A
STACK/E-HLFLEG	Stacking kit with legs for 2 half-size ovens	N/A	N/A	N/A	N/A	✓	N/A
VCE-STACKWIRE	Provides for single point connection for stacked electric ovens	Elec.	Elec.	Elec.	N/A	✓	N/A
DRIPPAN-SSDD	Stainless steel drip pan	✓	✓	✓	✓	N/A	N/A
3/4QD-HOSE-4	¾" x 4' quick disconnect hose with restraining device	✓	✓	✓	✓	N/A	N/A
ENCLSUR-SSBACK	Stainless steel rear enclosure (per section)	✓	N/A	✓	✓	N/A	N/A
VC5-ENCLSR-BCK	Stainless steel rear enclosure (per section)	N/A	✓	N/A	N/A	N/A	N/A
MARINE-TOP	Oven/Steamer accessory kit. Requires 8" legs (LEGSET-8INSS) in lieu of standard legs	✓	N/A	N/A	N/A	N/A	N/A

FACTORY-INSTALLED OPTIONS

Description	VC4	VC5	VC6	SG
Simultaneous doors (per section)—chain driven	✓	N/A	✓	✓
480V, 60 Hz, 3 Phase (per section)—VC Electric Models	Elec.	Elec.	Elec.	N/A
Corrections package 1—security screws only	✓	N/A	✓	✓
Corrections package 2—security screws, rear enclosure, locking hasp for doors	✓	N/A	✓	✓
Left side controls	✓	N/A	N/A	N/A
Kosher-friendly control package (per section) includes standing pilot and continuously operating fan functions	✓	N/A	✓	✓

GRIDDLE LINE UP

Vulcan continues to lead the industry with its extensive line up of reliable, high-performance griddles. From fully customizable platforms to quick-ship standard models, Vulcan offers both gas and electric countertop options designed to meet the demands of any kitchen.

And with exclusive technology like Rapid Recovery™ and IRX™ Vulcan griddles increase production of consistent, great-tasting results.



	VCCG	MSA	900RX	VMG	VCRG	HEG	RRE
ENERGY STAR® certified	 select models	N/A	N/A	N/A	N/A	N/A	N/A
Utility	Gas	Gas	Gas	Gas	Gas	Electric	Electric
Controls	Solid state	Snap action	Snap action	Manual	VCRG-M: Manual VCRG-T: Snap action	Snap action	Snap action
Burner Spacing	12"	12"	12"	12"	12"		
Temp. Range	200°F - 550°F	200°F - 550°F (450°F Rapid Recovery)	200°F - 550°F	Up to 650°F	Up to 550°F	200°F - 450°F	200°F - 450°F
Cooking height	14 ¾"	11 ⅞"	11 ⅞"	11 ⅞"	12 ½"	11 ⅞"	11 ⅞"
Legs	4" Adjustable	4" Adjustable	4" Adjustable	4" Adjustable	4" Adjustable	4" Adjustable	4" Adjustable
Clamshell compatible	✓	✓	✓	N/A	N/A	✓	✓
Sizes available	5	5	5	5	3	5	3



VCCG SERIES | Optimize the Griddle Workstation

Vulcan's high-performance VCCG Griddle distributes heat evenly across the entire griddle plate, boosting food quality and reliability in the most demanding environments. Plus, it's easy to customize your griddle to your specific operational needs: choose from three plate options, grease trough location, and other options and accessories.

STANDARD FEATURES:

- Flexible griddle platform enables you to select from 2 burner systems (IRX™ Infrared or atmospheric) and 3 plate materials (Steel, Rapid Recovery™ or Chrome).
- Every 12" is independently zoned with embedded solid state temperature control from 200–550°F on Steel and Chrome plates and 200–450°F on Rapid Recovery™ Plate.
- Electronic ignition and pilot protection system.
- 4" heavy duty adjustable legs.
- Cool-to-the-touch bullnose design keeps the front rail cool at all times.
- Built-in regulator per burner (every 12").
- High-capacity 6 quart grease drawer— 2 for 60" and 72" sizes.
- Select models are ENERGY STAR® certified.



IRX™ is Infrared Extreme, a true infrared platform that brings productivity, energy savings, and ease of operation to the end user — producing consistent results batch after batch.



VCCG60



VCCG72

VCCG GRIDDLES | BASE MODELS

Model	Dimensions (W x D x H)	Cooking Height	Plate	Burner System	No. of Burners	No. of Drawers	Grease Trough
VCCG24	24" x 33 ¹ / ₈ " x 18 ⁷ / ₈ "	14 ³ / ₄ "	Steel	Atmospheric or IRX™ Infrared	2	1	Front
VCCG36	36" x 33 ¹ / ₈ " x 18 ⁷ / ₈ "	14 ³ / ₄ "	Steel	Atmospheric or IRX™ Infrared	3	1	Front
VCCG48	48" x 33 ¹ / ₈ " x 18 ⁷ / ₈ "	14 ³ / ₄ "	Steel	Atmospheric or IRX™ Infrared	4	1	Front
VCCG60	60" x 33 ¹ / ₈ " x 18 ⁷ / ₈ "	14 ³ / ₄ "	Steel	Atmospheric or IRX™ Infrared	5	2	Front
VCCG72	72" x 33 ¹ / ₈ " x 18 ⁷ / ₈ "	14 ³ / ₄ "	Steel	Atmospheric or IRX™ Infrared	6	2	Front

- Rapid Recovery™ Plate only available in 24" depth and NOT available in 72" width.
- BTUs, dimensions, and weights depend on customization selection. Contact factory for further details.
- Contact factory for second year warranty information.
- VMCS not compatible with rear grease trough.



VCCG SERIES | Easy Customization to Fit Your Operational Needs

1. Choose Plate	2. Choose Burner		3. Choose Grease Trough Location			4. Select Factory-Installed Options			5. Select Field-Installed Accessories				
	IRX™ Infrared (24,000 BTU/hr)	Atmospheric (30,000 BTU/hr)	Front	Left Side	Rear	10" Back Splash	Towel Bar	Under-Device Plumbing	Plate Rail	Condiment Rail	Cutting Board	Integrated Stand (37" Cooking Height)	Banking Strip
Steel (1" Thick plate)	•	•	•	•	•	•	•	•	•	•	•	•	•
Rapid Recovery™ (18 mm [$\approx 3/4$ "] thick plate)	•	•	•	—	—	—	•	•	•	•	•	•	•
Chrome (1" Thick plate. Ships with palmetto brush, scraper and blade for cleaning.)	•	•	•	•	—	•	•	•	•	•	•	•	•



VCCG24



VCCG36



VCCG48



VCCG models are **Vulcan Manual Clamshell (VMCS)** compatible. Learn more on page 76.

How to choose the right griddle plate



VCCG SERIES | *Factory-Installed Options and Stands*

DESCRIPTION	OPTION	FOR
10" Back splash and tapered side splash. <i>Available on steel and chrome plates; not available on Rapid Recovery™ plate.</i>	10" Back Splash	All VCCG
Under-device plumbing, front left location.	Under-Device Plumbing	All VCCG
Stainless steel towel bar to hang towels, bar cloths or utensils.	Towel Bar	All VCCG



10" back splash

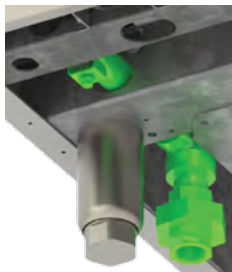

Under-device plumbing

INTEGRATED EQUIPMENT STANDS

Equipment stand integrated into griddle unit (37" working height)

Item #	For
ISTAND/C-CG24	VCCG24
ISTAND/C-CG36	VCCG36
ISTAND/C-CG48	VCCG48
ISTAND/C-CG60	VCCG60
ISTAND/C-CG72	VCCG72



IMAGE NOT AVAILABLE

VCCG SERIES | Field-Installed Accessories and Stands

	DESCRIPTION	ITEM #	FOR
	STAND 30" depth stainless steel stand with ½" marine edge and 5" casters (deck height is 24" from floor level)	STAND/C-24 STAND/C-36 STAND/C-48 STAND/C-60 STAND/C-72	All 24" Countertop Equip. All 36" Countertop Equip. All 48" Countertop Equip. All 60" Countertop Equip. All 72" Countertop Equip.
	PLATE RAIL Stainless steel plate rail, 10⅝" depth	PLTRAIL-CG24 PLTRAIL-CG36 PLTRAIL-CG48 PLTRAIL-CG60 PLTRAIL-CG72	VCCG24 VCCG36 VCCG48 VCCG60 VCCG72
	CONDIMENT RAIL Stainless steel condiment rail, 10⅝" depth; pans not included	CONRAIL-CG24 Capacity: (3) ⅙ Pans or (1) ⅓ Pan CONRAIL-CG36 Capacity: (5) ⅙ Pans or (2) ⅓ Pans CONRAIL-CG48 Capacity: (7) ⅙ Pans or (3) ⅓ Pans CONRAIL-CG60 Capacity: (8) ⅙ Pans or (4) ⅓ Pans CONRAIL-CG72 Capacity: (10) ⅙ Pans or (5) ⅓ Pans	VCCG24 VCCG36 VCCG48 VCCG60 VCCG72
	CUTTING BOARD Stainless steel cutting board with Sani-Tuff®, 10⅝" depth <i>(Sani-Tuff® is a resilient material resistant to cracking, splintering, and absorption of liquids)</i>	CUTBD-CG24 CUTBD-CG36 CUTBD-CG48 CUTBD-CG60 CUTBD-CG72	VCCG24 VCCG36 VCCG48 VCCG60 VCCG72
	BANKING STRIP Connect two adjacent griddles together	BANKING-STRIP	All VCCG
	CHUTE EXTENSION Replace grease can for operations producing excessive grease. Must be used with IStand/C-CG.	EXTENSION-CHUTE	All VCCG
	Transformer 220V to 120V	TRANSF-900RE	All VCCG

900RX & MSA SERIES | *Heavy Duty Performance, Convenience and Reliability*

STANDARD FEATURES:

- 27,000 BTUs per 12" section, U-shaped steel burners.
- 1" thick steel plate, 24" deep.
- Embedded mechanical snap-action thermostat provides accurate temperature control from 200–550°F (+/- 15°F to set point at idle).
- 1 supervised pilot safety valve for every 2 burners; valve will completely shut off gas to pilot and burners if pilot extinguishes or gas supply is interrupted.
- 4" heavy duty adjustable legs.
- Cool-to-the-touch bullnose design keeps the front rail cool at all times.
- High-capacity 6-quart grease drawer— 2 for 60" and 72" sizes.
- External gas regulator provided in packaging.
- 900RX & MSA models are Vulcan Manual Clamshell (VMCS) compatible.



936RX

Dual electric/manual ignition with front manifold shut off valve provides convenience to busy operators (900 Series)



MSA48

Manual ignition (MSA Series)

900RX GRIDDLES | DUAL ELECTRIC/MANUAL IGNITION

Model	Dimensions (W x D x H)	Cooking Height	Total BTU/hr	No. of Drawers
924RX	24" x 31½" x 15¼"	11⅞"	54,000	1
936RX	36" x 31½" x 15¼"	11⅞"	81,000	1
948RX	48" x 31½" x 15¼"	11⅞"	108,000	1
960RX	60" x 31½" x 15¼"	11⅞"	135,000	2
972RX	72" x 31½" x 15¼"	11⅞"	162,000	2

Also available with a 30" deep steel plate.

MSA GRIDDLES | MANUAL IGNITION

Model	Dimensions (W x D x H)	Cooking Height	Total BTU/hr	No. of Drawers
MSA24	24" x 31½" x 15¼"	11⅞"	54,000	1
MSA36	36" x 31½" x 15¼"	11⅞"	81,000	1
MSA48	48" x 31½" x 15¼"	11⅞"	108,000	1
MSA60	60" x 31½" x 15¼"	11⅞"	135,000	2
MSA72	72" x 31½" x 15¼"	11⅞"	162,000	2

Also available with exclusive Rapid Recovery™ composite griddle plate or a 30" deep steel plate.

900RX & MSA SERIES | *Factory-Installed Options*

	OPTION	DESCRIPTION	FOR
	30" Depth Steel Plate	30" Deep steel plate; 1" thick, temperature control from 200–550°F	All 900RX/MSA
	Chrome Plate	24" or 30" Depth chrome plate. Ships with palmetto brush, scraper, and blade for cleaning	All 900RX/MSA
	Rapid Recovery™ Plate	Vulcan's exclusive composite plate with aluminum core and 304 series stainless steel surface; temperature control from 200–450°F <i>Only available in 24" depth</i>	MSA24 MSA36 MSA48
	Rear Grease Trough	Grease trough located on rear of griddle vs. standard front <i>VCMS, standard plate rail, condiment rail and cutting board accessories are incompatible with rear grease trough griddles</i>	All 900RX/MSA
	Under-Device Plumbing	Under-device plumbing, front right location	All 900RX/MSA
	10" Back Splash	10" Back splash and tapered side splash, available on steel and chrome plates; not available on Rapid Recovery™ plate	All 900RX/MSA
	Piezo Ignition System	Rotary Piezoelectric Ignition System; no electric needed	All MSA

900RX & MSA SERIES | *Field-Installed Accessories and Stands*

	DESCRIPTION	ITEM #	FOR
	<p>PLATE RAIL Stainless steel plate rail, 10⁵/₈" depth <i>Standard plate rail accessories are incompatible with rear grease trough griddles</i></p>	<p>PLTRAIL-24 PLTRAIL-36 PLTRAIL-48 PLTRAIL-60 PLTRAIL-72</p>	<p>924RX and MSA24 936RX and MSA36 948RX and MSA48 960RX and MSA60 972RX and MSA72</p>
	<p>CONDIMENT RAIL Stainless steel condiment rail, 10⁵/₈" depth; pans not included. <i>Condiment rail accessories are incompatible with rear grease trough griddles</i></p>	<p>CONRAIL-24 Capacity: (3) 1/6 Pans or (1) 1/3 Pan CONRAIL-36 Capacity: (5) 1/6 Pans or (2) 1/3 Pans CONRAIL-48 Capacity: (7) 1/6 Pans or (3) 1/3 Pans CONRAIL-60 Capacity: (8) 1/6 Pans or (4) 1/3 Pans CONRAIL-72 Capacity: (10) 1/6 Pans or (5) 1/3 Pans</p>	<p>924RX and MSA24 936RX and MSA36 948RX and MSA48 960RX and MSA60 972RX and MSA72</p>
	<p>CUTTING BOARD Stainless steel cutting board with Sani-Tuff®, 10⁵/₈" depth <i>Cutting board accessories are incompatible with rear grease trough griddles</i></p>	<p>CUTBD-24 CUTBD-36 CUTBD-48 CUTBD-60 CUTBD-72</p>	<p>924RX and MSA24 936RX and MSA36 948RX and MSA48 960RX and MSA60 972RX and MSA72</p>
	<p>LEGS 6" stainless steel legs</p>	<p>LEGS-GRD6</p>	<p>All 900RX/MSA</p>
	<p>HOSE 3/4" x 4' long gas flex hose and quick disconnect</p>	<p>3/4QD-HOSE-4</p>	<p>All 900RX/MSA</p>
	<p>BANKING STRIP Connect two adjacent griddles together</p>	<p>BANKING-STRIP</p>	<p>All 900RX/MSA</p>
 IMAGE NOT AVAILABLE	<p>INTEGRATED STAND Equipment stand integrated into griddle unit (37" working height)</p>	<p>ISTAND/C-24 ISTAND/C-36 ISTAND/C-48 ISTAND/C-60 ISTAND/C-72</p>	<p>924RX and MSA24 936RX and MSA36 948RX and MSA48 960RX and MSA60 972RX and MSA72</p>

VMG SERIES | *Heavy Duty Performance, Convenience and Reliability*

STANDARD FEATURES:

- 27,000 BTUs per 12" section, U-shaped steel burners.
- Manual controls are designed for high-heat operations.
- High-capacity 6-quart grease drawer —2 for 60" and 72" sizes.
- Stainless steel front, sides, and front top ledge with cool bullnose design.
- Fully welded stainless and aluminized steel chassis frame.
- One high range infinite heat control valve per burner.
- Bottom heat shields.
- Standing pilot ignition system.
- ¾" rear gas connection and pressure regulator.
- 11" low profile cooking height on 4" adjustable legs.
- 1" thick polished steel griddle plate with 12-gauge, 4" stainless steel back and tapered side splashes.
- Spatula wide 3½" grease gutter and grease chute is fully welded for easier cleaning and to stop grease migration.
- One-year limited parts and labor warranty.





VMG36

VMG SERIES GRIDDLES | MANUAL CONTROLS

Model	Dimensions (W x D x H)	Cooking Height	Total BTU/hr	No. of Drawers	No. of Burners
VMG24	24" x 31½" x 15¼"	11⅞"	54,000	1	2
VMG36	36" x 31½" x 15¼"	11⅞"	81,000	1	3
VMG48	48" x 31½" x 15¼"	11⅞"	108,000	1	4
VMG60	60" x 31½" x 15¼"	11⅞"	135,000	2	5
VMG72	72" x 31½" x 15¼"	11⅞"	162,000	2	6

VMG SERIES | *Field-Installed Accessories and Stands*

	DESCRIPTION	ITEM #	FOR			
	<p>PLATE RAIL Stainless steel plate rail, 10⁵/₈" depth <i>Standard plate rail accessories are incompatible with rear grease trough griddles</i></p>	<p>PLTRAIL-24 PLTRAIL-36 PLTRAIL-48 PLTRAIL-60 PLTRAIL-72</p>	<p>VMG24 VMG36 VMG48 VMG60 VMG72</p>			
		<p>CONDIMENT RAIL Stainless steel condiment rail, 10⁵/₈" depth; pans not included <i>Condiment rail accessories are incompatible with rear grease trough griddles</i></p>	<p>CONRAIL-24 Capacity: (3) 1/6 Pans or (1) 1/3 Pan CONRAIL-36 Capacity: (5) 1/6 Pans or (2) 1/3 Pans CONRAIL-48 Capacity: (7) 1/6 Pans or (3) 1/3 Pans CONRAIL-60 Capacity: (8) 1/6 Pans or (4) 1/3 Pans CONRAIL-72 Capacity: (10) 1/6 Pans or (5) 1/3 Pans</p>	<p>VMG24 VMG36 VMG48 VMG60 VMG72</p>		
			<p>CUTTING BOARD Stainless steel cutting board with Sani-Tuff®, 10⁵/₈" depth <i>Cutting board accessories are incompatible with rear grease trough griddles</i></p>	<p>CUTBD-24 CUTBD-36 CUTBD-48 CUTBD-60 CUTBD-72</p>	<p>VMG24 VMG36 VMG48 VMG60 VMG72</p>	
				<p>HOSE 3/4" x 4' long gas flex hose and quick disconnect</p>	<p>3/4QD-HOSE-4</p>	<p>All VMG</p>
				<p>UNIVERSAL EQUIPMENT STANDS 30" Depth stainless steel stand with 1/2" marine edge and 5" casters (deck height is 24" from floor level)</p>	<p>STAND/C-24 STAND/C-36 STAND/C-48 STAND/C-60 STAND/C-72</p>	<p>All 24" Countertop Equip. All 36" Countertop Equip. All 48" Countertop Equip. All 60" Countertop Equip. All 72" Countertop Equip.</p>

RRE SERIES | *Rapid Recovery™ Composite Plate Griddle*

The Rapid Recovery™ Composite Plate Griddle with 304 series stainless steel cooking surface supports high-volume kitchen applications while achieving high-capacity, consistent results.

STANDARD FEATURES:

- True “corner-to-corner” temperature control across cooking surface to maximize production capacity.
- Rapid Recovery™ composite griddle plate (≈¾") delivers fast and uniform heat.
- 304 series stainless steel cooking surface is easy to clean and reduces labor and flavor transfer between foods.
- Available in 208 or 240V, 50-60 Hz, 1 or 3 Phase power supply and 480V, 50-60 Hz, 3 Phase.
- Snap-action thermostatic controls and heating elements every 12" with temperature control from 200–450°F.
- 4" heavy duty adjustable legs.
- Cool-to-the-touch bullnose design keeps the front rail cool at all times.



RRE36E



RRE models are **Vulcan Manual Clamshell (VMCS)** compatible

RRE SERIES GRIDDLES

Model	Dimensions (W x D x H)	Cooking Height	Total kW	No. of Drawers
RRE24E	24" x 31½" x 15¼"	11⅞"	10.8	1
RRE36E	36" x 31½" x 15¼"	11⅞"	16.2	1
RRE48E	48" x 31½" x 15¼"	11⅞"	21.6	1

Contact factory for 380-415V options.

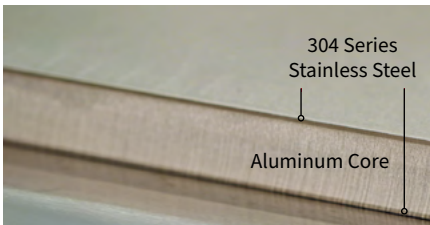

Composite Plate with Aluminum Core and 304 Series Stainless Steel Surface.

Exclusive Rapid Recovery™ composite plate material

Corner-to-corner temperature control and even heat distribution allows users to cook to perfection on every inch of this griddle’s surface.

Scan to learn more about Rapid Recovery technology



HEG SERIES | Dependable Operation and Repeatable Performance

STANDARD FEATURES:

- Available in 208 or 240V, 50-60 Hz, 1 or 3 Phase power supply and 480V, 50-60 Hz, 3 Phase power supply. **HEG60E and HEG72E require 2 separate power supplies.**
- ½" steel plate for 24", 36", and 48" units; ¾" steel plate for 60" and 72" units—designed for optimal grill performance.
- Snap-action thermostatic controls and heating elements every 12" with temperature control from 200–450°F.
- 4" heavy duty adjustable legs.
- Cool-to-the-touch bullnose design keeps the front rail cool at all times.
- High-capacity 6 quart grease drawer—2 for 60" and 72" sizes.



HEG36E



HEG models are **Vulcan Manual Clamshell (VMCS)** compatible

HEG SERIES GRIDDLES

Model	Dimensions (W x D x H)	Cooking Height	Total kW	No. of Drawers
HEG24E	24" x 31½" x 15¼"	11⅛"	10.8	1
HEG36E	36" x 31½" x 15¼"	11⅛"	16.2	1
HEG48E	48" x 31½" x 15¼"	11⅛"	21.6	1
HEG60E*	60" x 31½" x 15¼"	11⅛"	27	2
HEG72E*	72" x 31½" x 15¼"	11⅛"	32.4	2

*HEG60E and HEG72E require 2 separate power supplies. Contact factory for 380-415V options.

HEG SERIES | *Factory-Installed Options and Stands*

FACTORY-INSTALLED OPTIONS



OPTION	DESCRIPTION	FOR
Chrome Plate	24" depth chrome plate. Ships with palmetto brush, scraper, and blade for cleaning	All HEG

UNIVERSAL EQUIPMENT STANDS

30" Depth stainless steel stand with 1/2" marine edge and 5" casters (deck height is 24" from floor level).

STAND/C-24	All 24" countertop equipment
STAND/C-36	All 36" countertop equipment
STAND/C-48	All 48" countertop equipment
STAND/C-60	All 60" countertop equipment
STAND/C-72	All 72" countertop equipment



HEG SERIES | *Field-Installed Accessories*



DESCRIPTION

PLATE RAIL

Stainless steel plate rail, 10⁵/₈" depth
Standard plate rail accessories are incompatible with rear grease trough griddles

ITEM

PLTRAIL-24
PLTRAIL-36
PLTRAIL-48
PLTRAIL-60
PLTRAIL-72

FOR

HEG924E / RRE24E
 HEG36RD / RRE36E
 HEG48E / RRE48E
 HEG60E / RRE60E
 HEG72E / RRE72E



CONDIMENT RAIL

Stainless steel condiment rail, 10⁵/₈" depth; pans not included
Condiment rail accessories are incompatible with rear grease trough griddles

CONRAIL-24

HEG924E / RRE24E
 Capacity: (3) 1/6 Pans or (1) 1/3 Pan

CONRAIL-36

HEG36RD / RRE36E
 Capacity: (5) 1/6 Pans or (2) 1/3 Pans

CONRAIL-48

HEG48E / RRE48E
 Capacity: (7) 1/6 Pans or (3) 1/3 Pans

CONRAIL-60

HEG60E / RRE60E
 Capacity: (8) 1/6 Pans or (4) 1/3 Pans

CONRAIL-72

HEG72E / RRE72E
 Capacity: (10) 1/6 Pans or (5) 1/3 Pans



CUTTING BOARD

Stainless steel cutting board with Sani-Tuff®, 10⁵/₈" depth
Cutting board accessories are incompatible with rear grease trough griddles

CUTBD-CG24

HEG924E / RRE24E

CUTBD-CG36

HEG36RD / RRE36E

CUTBD-CG48

HEG48E / RRE48E

CUTBD-CG60

HEG60E / RRE60E

CUTBD-CG72

HEG72E / RRE72E



LEGS

6" stainless steel legs

LEGS-GRD6

All HEG(E) & RRE(E)



BANKING STRIP

Connect two adjacent griddles together

BANKING-STRIP

All HEG(E) & RRE(E)

IMAGE NOT AVAILABLE

INTEGRATED STAND

Equipment stand integrated into griddle unit (37" working height)

ISTAND/C-24

HEG924E / RRE24E

ISTAND/C-36

HEG36RD / RRE36E

ISTAND/C-48

HEG48E / RRE48E

ISTAND/C-60

HEG60E / RRE60E

ISTAND/C-72

HEG72E / RRE72E

VMCS | Manual Clamshell Griddle Accessory

Maximize griddle output, cut cook times by over 50%, and achieve consistent results by cooking with a Manual Clamshell Griddle Accessory.

STANDARD FEATURES:

- One-hand lift mechanism holds system in an upright position for ease of operation.
- 10.4" W x 22.9" D cooking surface accommodates a variety of menu items.
- Rapid Recovery™ platen (1/16") for fast temperature recovery and even heating.
- Snap-action thermostat supports cooking range from 200–450°F.
- Compatible with heavy duty Vulcan gas and electric griddles: VCCG, 900RX, MSA, HEG(E), and RRE(E) Series units.
- Plate Gap Adjustment Accessory (GADJUST-VMCS) adjusts height of the clamshell in 1/32" increments.



VMCS-101
Shown with GADJUST-ROTARY mounted to a VCCG24 Griddle

VMCS CLAMSHELL ACCESSORY

Model	Available on	Description	Total kW	Nominal Amp Draw
VMCS-101*	VCCG, 900RX, MSA, HEG(E), RRE(E)	10.4" Rapid Recovery™ Smooth Platen <i>Includes Plate Gap Adjustment (GADJUST-VMCS), Non-stick sheet mounting hardware, and 2 non-stick sheets</i>	3.6	17.3
VMCS-201*	VCCG, 900RX, MSA, HEG(E), RRE(E)	10.4" Grooved Steel Platen <i>Includes Plate Gap Adjustment (GADJUST-VMCS), Non-stick sheet mounting hardware, and 2 non-stick sheets</i>	3.6	17.3

***Mounting Frame required.**

- Not available with 30" depth griddles or griddles with rear grease trough.
- Please specify 208V, 1 Phase or 240V, 1 Phase electrical service. 240V available at the same price. Contact factory for lead time.



VMCS-101



VMCS-201 Shown with GADJUST-ROTARY



View Clamshell Demo Video

VMCS | Manual Clamshell Griddle Field-Installed Accessories and Options

FIELD-INSTALLED ACCESSORIES

MOUNTING FRAME

Mounting frame
Required for mounting clamshell to griddle



For 900RX, MSA, HEG(E), RRE(E) Griddles:

- FRAME-VMCS24** (24" mounting frame)
- FRAME-VMCS36** (36" mounting frame)
- FRAME-VMCS48** (48" mounting frame)
- FRAME-VMCS60** (60" mounting frame)
- FRAME-VMCS72** (72" mounting frame)

For VCCG Griddles:

- FRAME-VMCS24-CG** (24" mounting frame)
- FRAME-VMCS36-CG** (36" mounting frame)
- FRAME-VMCS48-CG** (48" mounting frame)
- FRAME-VMCS60-CG** (60" mounting frame)
- FRAME-VMCS72-CG** (72" mounting frame)

ROTARY GAP ADJUSTMENT

Easy-to-use rotary gap adjustment allows customization to height of menu items



GADJUST-ROTARY

For VMCS-101 & VMCS-201



NON-STICK RELEASE SHEETS

qty 10

VMCSSHEET-KIT10B

For VMCS-101 & VMCS-201

FACTORY-INSTALLED OPTIONS

Item #	Description	Available on
VMCS-101FM	Factory staff will mount VMCS to new griddle on original PO, mounting frame purchase is required	VCCG, 900RX, MSA, HEG(E), RRE(E)
VMCS-201FM		VCCG, 900RX, MSA, HEG(E), RRE(E)



CHARBROILERS - GAS

CHARBROILER LINE UP

Vulcan charbroilers set the standard for durability, performance and food quality in the foodservice industry. With features such as heat deflector panels, a patented grate design and exclusive IRX™ infrared burner technology, our charbroilers deliver increased production capacity while conserving gas usage to maximize your cooking operation.



	VTEC	VACB (Achiever)	VCCB (Low profile)	VCRB (Counter Restaurant)
Utility	Gas (NG or LP)	Gas (NG or LP)	Gas (NG or LP)	Gas (NG or LP)
Heat Source	IRX™ Infrared	Radiants / Cast Iron	Radiants / Cast Iron	Radiants / Cast Iron
Production	Heavy duty	Heavy duty	Heavy duty	Medium duty
Working height	12½"	12"	13"	13"
Legs	4" Adjustable	4" Adjustable	4" Adjustable	4" Adjustable
Sizes available	5	5	5	2

VTEC SERIES | *Increased Production Capacity & Food Quality with Decreased Gas Usage*

The VTEC charbroiler is ideal for cooking lean chicken, fish, and vegetables.



VTEC36

STANDARD FEATURES:

- Patented grate design virtually eliminates flare-ups.
- Energy-efficient 22,000 BTU/hr independent burner sections every 12".
- 11" x 25" stainless steel cooking grids providing ≈2 ft² of cooking area in each burner zone.
- Rotary piezo igniter provides direct spark to burner—no standing pilots, no electric needed.
- 4" heavy duty adjustable legs.
- Cool-to-the-touch bullnose design keeps the front rail cool at all times.

VTEC SERIES GRIDDLES

Model	Dimensions (W x D x H)	Cooking Height	Total BTU/hr	Burner Sections
VTEC14	14 ³ / ₈ " x 35 ¹ / ₈ " x 16 ³ / ₈ "	12 ¹ / ₂ "	22,000	1
VTEC25	25 ³ / ₈ " x 35 ¹ / ₈ " x 16 ³ / ₈ "	12 ¹ / ₂ "	44,000	2
VTEC36	36 ³ / ₈ " x 35 ¹ / ₈ " x 16 ³ / ₈ "	12 ¹ / ₂ "	66,000	3
VTEC48	47 ³ / ₈ " x 35 ¹ / ₈ " x 16 ³ / ₈ "	12 ¹ / ₂ "	88,000	4
VTEC60	58 ³ / ₈ " x 35 ¹ / ₈ " x 16 ³ / ₈ "	12 ¹ / ₂ "	110,000	5

FIELD-INSTALLED ACCESSORIES

CONDIMENT RAIL

Stainless steel condiment rail, 10⁵/₈" depth.

CONRAIL-VTEC25 For VTEC25

Capacity: (3) 1/6 Pans or (1) 1/3 Pan

CONRAIL-VTEC36 For VTEC36

Capacity: (5) 1/6 Pans or (2) 1/3 Pans

CONRAIL-VTEC48 For VTEC48

Capacity: (7) 1/6 Pans or (3) 1/3 Pans

CONRAIL-VTEC60 For VTEC60

Capacity: (8) 1/6 Pans or (4) 1/3 Pans

PLATE RAIL

Stainless steel plate rail, 10⁵/₈" depth.

PLTRAIL-VTEC14 For VTEC14

PLTRAIL-VTEC25 For VTEC25

PLTRAIL-VTEC36 For VTEC36

PLTRAIL-VTEC48 For VTEC48

PLTRAIL-VTEC60 For VTEC60

CUTTING BOARD

Stainless steel cutting board with Sani-Tuff®, 10⁵/₈" depth.

CUTBD-VTEC25 For VTEC25

CUTBD-VTEC36 For VTEC36

CUTBD-VTEC48 For VTEC48

CUTBD-VTEC60 For VTEC60

(Sani-Tuff® is a resilient material resistant to cracking, splintering, and absorption of liquids)

EMITTER PANEL*

Replacement emitter panels, qty 2.



EMITTER-VTEC All VTEC

FISH GRATE

Stainless steel fish grate 22 ribs, qty 1.

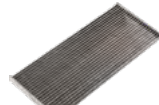

GRATE-VTFISH All VTEC

SCRAPER

Tool used to clean cooking grid



SCRAPER-VTEC All VTEC

*Cleaning of the emitter panels is a dry operation and done while in place. Water should never be poured onto hot emitter panels. Emitter panels should never be immersed in water for cleaning. Removing the emitter panels is not necessary except for servicing the unit. We recommend an operator carry 1 emitter panel on hand at all times. Once the operator learns the life span of the emitter panel in their specific operation, replacement can be added to a maintenance schedule. Hours of operation, food product and frequency of charbroiler cleaning are all factors in an emitter panel's life span.



CHARBROILERS - GAS

ACHIEVER VACB SERIES | *Heavy Duty Performance, High Production and Reliability*

Best temperature profile of any charbroiler in its class with more usable heat (600–700°F) into the grate area for maximum production capacity and productivity. Vulcan's “Supercharger” plates are standard—improving energy utilization and performance.

STANDARD FEATURES:

- Powerful 17,000 BTU/hr* burner in each 6" broiler section with wide range (220° rotation) manual gas valves for precise zone control.
- Heavy duty cast iron burners, radiants, and grates provide exceptional durability.
- Heat deflector panels below burner sections reflect heat into the cooking zone, improving uniformity of temperature across the entire cooking surface as well as protecting your refrigerated chef base.
- Easy-to-light design, standing pilot ignition.
- 4" heavy duty adjustable legs.



VACB36



VACB47 Achiever super-uniform temperature profile

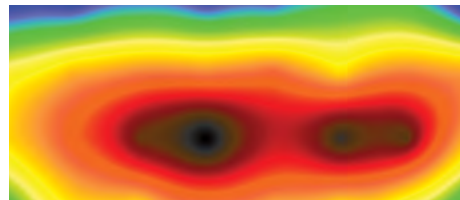





Competitor temperature profile

VACB SERIES GRIDDLES

Model	Dimensions (W x D x H)	Cooking Height	Total BTU/hr	Grates
VACB25	25 ¹ / ₈ " x 31" x 15 ¹ / ₂ "	12"	68,000	4
VACB36	36" x 31" x 15 ¹ / ₂ "	12"	102,000	6
VACB47	46 ⁷ / ₈ " x 31" x 15 ¹ / ₂ "	12"	136,000	8
VACB60	62 ¹ / ₈ " x 31" x 15 ¹ / ₂ "	12"	187,000	11
VACB72	72 ¹ / ₂ " x 31" x 15 ¹ / ₂ "	12"	221,000	13

*16,000 BTU/hr for propane gas.

ACHIEVER VACB SERIES | *Field-Installed Accessories*

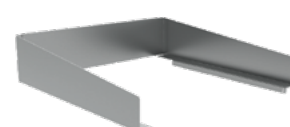
	DESCRIPTION	ITEM #	FOR
	<p>PLATE RAIL Stainless steel plate rail, 10⁵/₈" depth <i>Standard plate rail accessories are incompatible with rear grease trough griddles</i></p>	<p>PLTRAIL-ACB24 PLTRAIL-ACB36 PLTRAIL-ACB48 PLTRAIL-ACB60 PLTRAIL-ACB72</p>	<p>VACB25 VACB36 VACB48 VACB60 VACB72</p>
	<p>CONDIMENT RAIL Stainless steel condiment rail, 10⁵/₈" depth; pans not included <i>Condiment rail accessories are incompatible with rear grease trough griddles</i></p>	<p>CONRAIL-ACB24 Capacity: (3) 1/6 Pans or (1) 1/3 Pan CONRAIL-ACB36 Capacity: (5) 1/6 Pans or (2) 1/3 Pans CONRAIL-ACB48 Capacity: (7) 1/6 Pans or (3) 1/3 Pans CONRAIL-ACB60 Capacity: (8) 1/6 Pans or (4) 1/3 Pans CONRAIL-ACB72 Capacity: (10) 1/6 Pans or (5) 1/3 Pans</p>	<p>VACB25 VACB36 VACB48 VACB60 VACB72</p>
	<p>CUTTING BOARD Stainless steel cutting board with Sani-Tuff®, 10⁵/₈" depth <i>Cutting board accessories are incompatible with rear grease trough griddles</i></p>	<p>CUTBD-ACB24 CUTBD-ACB36 CUTBD-ACB48 CUTBD-ACB60 CUTBD-ACB72</p>	<p>VACB25 VACB36 VACB48 VACB60 VACB72</p>
	<p>LEGS 6" stainless steel legs</p>	<p>LEGS-GRD6</p>	<p>All VACB</p>
	<p>SPLASH KIT 6" add-on splash guard sides and back <i>(not compatible with OVERSHELF)</i></p>	<p>SPLASH6-CB25 SPLASH6-CB36 SPLASH6-CB36 SPLASH6-CB60 SPLASH6-CB72</p>	<p>VACB25 VACB36 VACB48 VACB60 VACB72</p>

ACHIEVER VACB SERIES | *Field-Installed Accessories*

	DESCRIPTION	ITEM #	FOR
	OVERSHELF 12¾" high shelf	OVRSHLF-ACB25 OVRSHLF-ACB36 OVRSHLF-ACB48 OVRSHLF-ACB60 OVRSHLF-ACB72	VACB25 VACB36 VACB48 VACB60 VACB72
	ROUND ROD GRATE ½" round rod, 6" wide section	GRATE-RR724	All VACB
	WAFFLE GRATE Cast iron crisscross grate design	GRATE-WAFFLE24	All VACB
	CAST STRAIGHT GRATE Cast iron straight grate	GRATE-CSTR24	All VACB
	GRIDDLE PLATE Flat griddle plate, 10" wide	GRATE-GRID24	All VACB
	FAJITA PLATE WARMER Fajita plate warmer/holder (replaces 2 grate sections)	GRATE-FAJITA	All VACB

VCCB SERIES (LOW PROFILE) | A Winning Charbroiler for Kitchens of all Sizes

STANDARD FEATURES:

- Powerful 14,500 BTU/hr burner in each 6" broiler section.
- Heavy duty cast iron burners, radiants, and grates provide exceptional durability.
- 4" adjustable legs.
- Heat deflector panels beneath each burner reflect heat back into the cooking zone for even temperature across the entire surface, keep the crumb tray cool, and protect refrigerated bases.
- Easy-to-light design, standing pilot ignition.



VCCB47

VCCB SERIES GRIDDLES

Model	Dimensions (W x D x H)	Cooking Height	Total BTU/hr	Grates
VCCB25	25¼" x 27¼" x 14¾"	13"	58,000	4
VCCB36	36" x 27¼" x 14¾"	13"	87,000	6
VCCB47	46¾" x 27¼" x 14¾"	13"	116,000	8
VCCB60	60" x 27¼" x 14¾"	13"	159,500	11
VCCB72	72" x 27¼" x 14¾"	13"	188,500	13

FIELD-INSTALLED ACCESSORIES

WAFFLE GRATE

Cast iron crisscross grate design

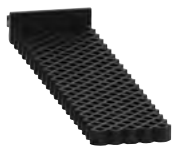

GRATE-WAFFLE
All VCCB / VCRB

DIAMOND GRATE

Cast iron diamond grate



GRATE-CDIA7
All VCCB / VCRB

SS DIAMOND GRATE

Stainless steel diamond grate



GRATE-SSDIA7
All VCCB / VCRB

ROUND ROD GRATE

½" Round rod, 6" wide section



GRATE-RROD7
All VCCB / VCRB

SPLASH KIT

6" Add-on splash guard sides and back (not compatible with overshef)

SPLASH6-CB25 For VCCB25

SPLASH6-CB36 For VCCB36

SPLASH6-CB47 For VCCB47

SPLASH6-CB60 For VCCB60

SPLASH6-CB72 For VCCB72

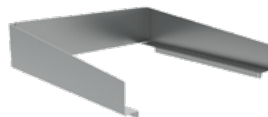

PLATE RAIL

Stainless steel plate rail, 10⅝" depth

PLTRAIL-VCCBB25 For VCCB25

PLTRAIL-VCCBB36 For VCCB36

PLTRAIL-VCCBB47 For VCCB47

PLTRAIL-VCCBB60 For VCCB60

PLTRAIL-VCCBB72 For VCCB72

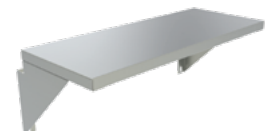

SMOKER BASES | Add Irresistible, Smoky Flavor to Fish, Meat, and More

STANDARD FEATURES:

- Heavy duty, stainless steel welded construction.
- Stainless crumb/grease tray with stainless wood platform, which accommodates blocks or logs.
- Designed to be placed on top of an equipment stand or refrigerated base with a temperature profile that will not affect base's performance.
- Available as a field installed accessory on VACB (produced after February 2013) and VCCB Gas Charbroilers.

WOOD ASSIST SMOKER BASE | COUNTERTOP MODEL

Item #	Description	Number of Wood Trays
SMOKER-VACB25	Achiever Smoker Base	1
SMOKER-VACB36	(Compatible with VACB Gas Charbroilers produced after February 2013)	2
SMOKER-VACB47	Adds 8 4/5" to height of overall unit	2
SMOKER-VACB60		3
CTSMOKER-VCCB25	Low Profile Smoker Base	1
CTSMOKER-VCCB36	(Compatible with VCCB Gas Charbroilers)	2
CTSMOKER-VCCB47	Adds 7 4/5" to height of overall unit	2
CTSMOKER-VCCB60		3



SMOKER-VACB36
Shown with VACB36 Charbroiler.



CTSMOKER-VCCB36
Shown with VCCB36 Charbroiler.

FIELD-INSTALLED ACCESSORY | COUNTERTOP MODEL

STAND/C-VACB25	
STAND/C-VACB36	Smoker Base Stand — Available on VACB and VCCB
STAND/C-VACB47	Countertop Wood Assist Smoker Bases
STAND/C-VACB60	

WOOD ASSIST SMOKER BASE | FLOOR MODEL

Item #	Description
SMOKR-VCCB36	Wood assist smoker base, featuring:
SMOKER-VCCB47	• Heavy duty, stainless steel welded construction
SMOKER-VCCB60	• Stainless steel under shelving
SMOKER-VCCB72	• Removable stainless steel water trays
	• Heavy duty, removable steel wood racks



SMOKER-VCCB72

VCRB, VCRH & VCRR SERIES | *Lower Working Height Ideal for use on Countertops*

STANDARD FEATURES (VCRB):

- Heavy duty cast iron char-radiants and reversible 5¼" wide, Flame Arrestor broiling grates.
- 14,500 BTU/hr heavy duty cast iron burners in each 6" section.
- Heat deflector panels beneath burner reflect heat back into the cooking zone, keep the crumb tray cool, and protect refrigerated bases.
- Stainless steel sides, control panel, top rim, and back splash.
- Standing pilot system with manual gas valves.
- 4" adjustable legs.

VCRB | RADIANT GAS CHARBROILERS

Model	Dimensions (W x D x H)	Cooking Height	Total BTU/hr
VCRB25	25½" x 27" x 13"	13"	58,000
VCRB36	36" x 27" x 13"	13"	87,000



VCRB25
Cast Iron Radiant Charbroiler

STANDARD FEATURES (VCRH / VCRR):

- Cast iron 25,000 BTU/hr (VCRH) or 20,000 BTU/hr (VCRR) 2-piece lift-off burners offer superior heating and flexibility.
- 1 manual control valve per burner.
- Removable tray around burners allows for additional ease of cleaning.
- Heavy duty cast iron top grates, 1 per burner, are designed to support heavy pans and stockpots (VCRH only).
- Fully welded stainless and aluminized steel chassis frame.
- 4" adjustable legs.

VCRH & VCRR | GAS HOT PLATES

Model	Dimensions (W x D x H)	Cooking Height	Total BTU/hr
VCRH12	12" x 29⅜" x 13⅜"	13"	50,000
VCRH24	24" x 29⅜" x 13⅜"	13"	100,000
VCRH36	36" x 29⅜" x 13⅜"	13"	150,000
VCRR24	24" x 15¼" x 12½"	12½"	40,000
VCRR36	36" x 15¼" x 12½"	12½"	80,000



VCRH24
Hot Plate

- Please indicate propane or natural gas while processing your order. VCRB and VCRH models are constructed standard for natural gas service; propane conversion kit is supplied with the unit. Conversion is the customer's responsibility.
- Please indicate elevation while processing your order. For VCRB and VCRH models, an elevation orifice kit is available free of charge for high-elevation applications. Installation is the customer's responsibility.

VCRG SERIES | Lower Working Height Ideal for use on Countertops

STANDARD FEATURES (VCRG-M):

- 1" thick polished steel griddle plate—20½" deep, with 3½" tapered stainless steel splashes fully top-seam welded for easy cleaning.
- 1 manual control valve per burner.
- (1) 25,000 BTU/hr U-shaped aluminized steel burner for every 12" of griddle width.
- Standing pilot system.
- Fully welded stainless and aluminized steel chassis frame.
- 4" adjustable legs.

VCRG-M | MANUAL GAS GRIDDLES

Model	Dimensions (W x D x H)	Cooking Height	Total BTU/hr
VCRG24-M	24" x 27" x 16"	12½"	50,000
VCRG36-M	36" x 27" x 16"	12½"	75,000
VCRG48-M	48" x 27" x 16"	12½"	100,000



VCRG24-M
Manual Griddle

STANDARD FEATURES (VCRG-T):

- 1" thick polished steel griddle plate—20½" deep, with 3½" tapered stainless steel splashes fully top-seam welded for easy cleaning.
- Embedded, mechanical snap-action thermostats for high performance and optimal response time; temperature adjusts from 200–450°F.
- (1) 25,000 BTU/hr U-shaped burner for every 12" of griddle width.
- 1 pilot safety valve for every 2 burners; valve will completely shut off gas to pilot and burners if pilot extinguishes.
- Fully welded stainless and aluminized steel chassis frame.
- 4" adjustable legs.

VCRG-T | THERMOSTATIC GAS GRIDDLES

Model	Dimensions (W x D x H)	Cooking Height	Total BTU/hr
VCRG24-T	24" x 27" x 16"	12½"	50,000
VCRG36-T	36" x 27" x 16"	12½"	75,000
VCRG48-T	48" x 27" x 16"	12½"	100,000



VCRG24-T
Embedded Snap-Action
Thermostatic Griddle

- Please indicate propane or natural gas while processing your order. VCRG models are constructed standard for natural gas service; propane conversion kit is supplied with the unit. Conversion is the customer's responsibility.
- Please indicate elevation while processing your order. For VCRG models, an elevation orifice kit is available free of charge for high-elevation applications. Installation is the customer's responsibility.

COUNTER RESTAURANT SERIES | *Field-Installed Accessories*



DESCRIPTION

ROUND ROD GRATE
 ½" round rod, 6" wide section

ITEM #

GRATE-RROD7

FOR

All VCRB

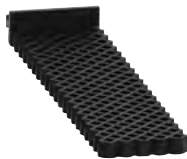

WAFFLE GRATE
 Cast iron crisscross grate design

GRATE-WAFFLE

All VCRB



DIAMOND GRATE
 Cast iron diamond grate

GRATE-CDIA7

All VCRB



SS DIAMOND GRATE
 Stainless steel diamond grate

GRATE-SSDIA7

All VCRB



SPLASH KIT
 4" VCRB Splash kit

SPLASH-VCRB

All VCRB



ALTITUDE KIT
 Orifice altitude kit

ALTIKIT-VCR

VCRG, VCRB,
 VCRH, VCRR



STEAMERS - COUNTER

COUNTERTOP STEAMERS | A Full Range Delivering Spectacular Results

When floor space is at a premium, Vulcan countertop steamers offer a solution. These countertop steamers are ideal for a variety of foods, including vibrant veggies, succulent seafood, and perfectly cooked proteins.

EO Boilerless

Low Maintenance



EA Plus

Enhanced Features



PowerSteam™

High Productivity



LWE (Low Water Energy)

High Efficiency



FEATURES / SPECS	EO Boilerless C24EO3 / AF C24EO5 / AF	EA Plus C24EA3 PLUS C24EA5 PLUS	PowerSteam™ C24EA3 PS C24EA5 PS	LWE C24EA3 LWE C24EA5 LWE
ENERGY STAR® certified		N/A	N/A	
High-Efficiency Steam Generator (Patent Pending)	N/A	✓	✓	✓
Professional Controls with Timer, Buzzer, Constant Steam Feature, Cook/Ready Lights	✓	✓	✓	✓
Two-Speed Staged Water Fill	N/A	✓	✓	✓
No Water Connection Required	✓	N/A	N/A	N/A
Automatic SmartDrain & PowerFlush™ System	N/A	✓	✓	✓
235°F Steam for 20% Faster Cooking Time	N/A	N/A	✓	N/A
Uses 90% Less Water and 50% Less Energy Versus Traditional Units	N/A	N/A	N/A	✓

EO SERIES - BOILERLESS | *Low Volume — Low Maintenance*

CONNECTIONLESS STANDARD FEATURES:

- Boilerless design for ease of use and low maintenance.
- No water connection required – manual fill.
- Rapid cooking with no fans or moving parts.
- Professional controls with 60-minute timer, buzzer, and constant steam feature.
- Illuminated power switch with low water and cook lights.
- Stainless steel exterior and cooking compartment.
- Heavy-duty door and latch mechanism.
- Long-life door gasket with exclusive Vulcan pan guard.
- Manual drain lever and flexible drain hose for easy positioning.
- High-efficiency steam control is ENERGY STAR® certified.

AUTO-FILL - WATER LINE CONNECTION STANDARD FEATURES:

Same features as connectionless standard steamer, plus:

- Water line connection for automatic water fill / refill.
- Electronic level sensing with no moving parts.
- Overfill sensor with water shut-off and buzzer.



C24E05
5-Pan Capacity



C24E03
3-Pan Capacity



EO SERIES - BOILERLESS | ELECTRIC

Model	Pan Capacity*	Input	Standard Power Supply
CONNECTIONLESS			
C24E03	3	8 kW	208V, 50-60 Hz, 3 Phase
C24E05	5	12 kW	208V, 50-60 Hz, 3 Phase
WITH AUTO-FILL WATER LINE CONNECTION			
C24E03AF	3	8 kW	208V, 50-60 Hz, 3 Phase
C24E05AF	5	12 kW	208V, 50-60 Hz, 3 Phase

Can be field converted to: 208V, 60-50 Hz, 1 Phase | 240V, 60-50 Hz, 3 Phase | 240V, 60-50 Hz, 1 Phase.
*12" x 20" x 2½" Pan



STEAMERS - COUNTER

EA SERIES - PLUS | À la Carte Steamer with Enhanced Features

Accelerate your kitchen with faster startup and continuous steam generation for nonstop cooking performance with Smart Fill technology.

STANDARD FEATURES:

- Professional controls with 60-minute timer, buzzer, cook/ready lights, power switch, and constant stream feature.
- Stainless steel exterior and cooking compartments with coved interior corners.
- Heavy duty door and latch mechanism.
- Long-life door gasket with exclusive Vulcan pan guard.
- Dual water line connection.
- External delimiting port.
- Staged water fill for superior heat-up and steam quality.
- High output stainless steel generator with auto SmartDrain™ & PowerFlush™ System.



C24EA3 PLUS
3-Pan Capacity



C24EA5 PLUS
5-Pan Capacity

EA PLUS | ELECTRIC

Model	Pan Capacity*	Input	Standard Power Supply
C24EA3 PLUS	3	8.5 kW	208V, 50-60 Hz, 3 Phase
C24EA5 PLUS	5	15 kW	208V, 50-60 Hz, 3 Phase

Can be field converted to: 208V, 60-50 Hz, 1 Phase | 240V, 60-50 Hz, 3 Phase | 240V, 60-50 Hz, 1 Phase.

**12" x 20" x 2½" Pan*



View operational video

EA SERIES - POWERSTEAM™ | *The Faster à la Carte Steamer*

PowerSteam™ enables greater production in a smaller footprint than other types of cooking equipment and requires less labor. Achieve faster cooking times with continuous high-volume steam.

STANDARD FEATURES

- Superheated 235°F high-energy steam.
- Staged water fill for superior heat-up and steam quality.
- Professional controls with 60-minute timer, buzzer, cook/ready lights, power switch, and constant steam feature.
- Stainless steel exterior and cooking compartments with coved interior corners.
- Heavy duty door and latch mechanism.
- Long-life door gasket with exclusive Vulcan pan guard.
- Dual water line connection.
- External delimiting port.
- High output stainless steel generator with auto SmartDrain™ & PowerFlush™ System.



C24EA5 PS
5-Pan Capacity



C24EA5 PS (QTY 2)
Shown with STAND 15VSG, STCKKIT 24EA and STCKKIT CST6

EA SERIES - POWERSTEAM™ TECHNOLOGY | ELECTRIC

Model	Pan Capacity*	Input	Standard Power Supply
C24EA3 PS	3	9.25 kW	208V, 50-60 Hz, 3 Phase
C24EA5 PS	5	15.75 kW	208V, 50-60 Hz, 3 Phase

Can be field converted to: 208V, 60-50 Hz, 1 Phase | 240V, 60-50 Hz, 3 Phase | 240V, 60-50 Hz, 1 Phase.
*12" x 20" x 2½" Pan



View overview video



EA SERIES - LWE | *Extreme Water Savings, Amazing Steam Power*

The LWE steamer recognizes when it needs to create steam and when to shut off. Less water means less scale buildup. Less buildup means fewer filter changes, resulting in higher production and increased savings.

STANDARD FEATURES

- Uses 90% less water versus traditional models, while maintaining cook time.
- Professional controls with 60-minute timer, buzzer, cook/ready lights, power switch, and constant steam feature.
- Stainless steel exterior and cooking compartments with coved interior corners.
- Cook multiple foods without flavor transfer.
- ENERGY STAR® certified and uses 50% less energy versus traditional models.



C24EA5 LWE
Shown with STAND 34YSGL
and CASTERS XSGL

EA SERIES - LWE TECHNOLOGY | ELECTRIC

Model	Pan Capacity*	Input	Standard Power Supply
C24EA3 LWE	3	8.5 kW	208V, 50-60 Hz, 3 Phase
C24EA5 LWE	5	15 kW	208V, 50-60 Hz, 3 Phase

Can be field converted to: 208V, 60-50 Hz, 1 Phase | 240V, 60-50 Hz, 3 Phase | 240V, 60-50 Hz, 1 Phase.

**12" x 20" x 2½" Pan*



View technology video

FIELD-INSTALLED STANDS & STAND ACCESSORIES

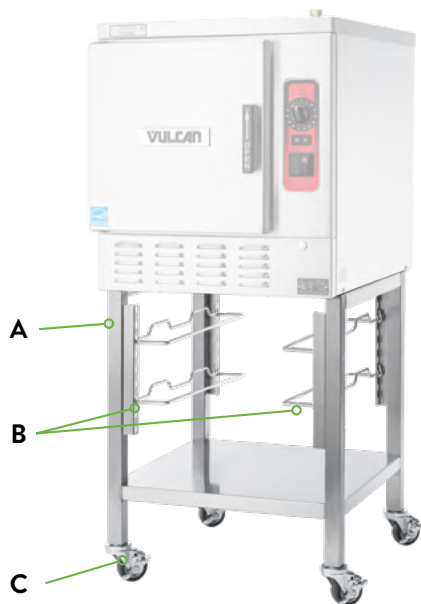

FOR COUNTERTOP STEAMERS:

A. STANDS

Stainless steel counter steamer equipment stand with flanged feet includes 1 set of removable pan slides (does not include casters)

STAND 28YSGL
24" Wide x 28" High

STAND 34YSGL
24" Wide x 34" High

Available for:
C24EA3 or 5 PLUS
C24EA3 or 5 PS
C24EA3 or 5 LWE
C24EO3 or 5 Boilerless

B. PAN SLIDES

Extra pair of universal pan slides for stands

Y/PAN SLIDES
For STAND 28YSGL
and STAND 34YSGL

C. CASTERS

6" Casters, set of 4, swivel breaking
Weight limit of 350lbs per wheel

CASTERS XSGL
For STAND 28YSGL
and STAND 34YSGL

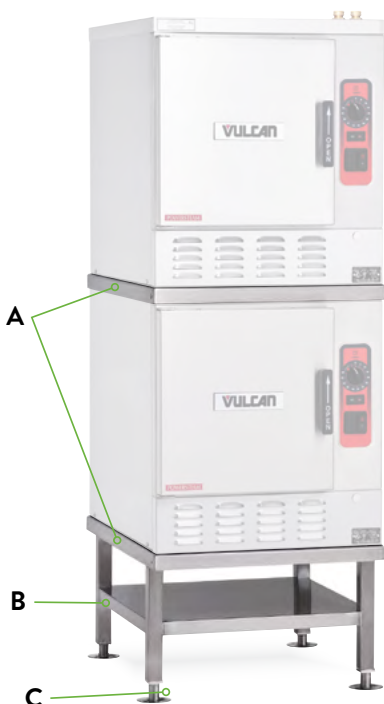

FOR STACKED COUNTERTOP STEAMERS:

A. STACKING KIT

Stacking kit for (2) countertop steamers, includes stacking plate and base plate (fig. A) (does not include *casters, *legs or stand)

STCKKIT 24EA

Available for:
C24EA3 or 5 PLUS
C24EA3 or 5 PS
C24EA3 or 5 LWE
C24EO3 or 5 Boilerless

**Legs or casters are required for stacking kit.*

B. STAND

Stainless steel counter steamer equipment stand for stacked steamers

STAND 15YSGL
24" Wide x 15" High

For STCKKIT 24EA

C. LEGS*

6" Legs, set of 4, with flanged feet for stacking kit (floor mount)

STCKKIT FLG6
For STCKKIT 24EA

— OR —

CASTERS*

6" Casters, set of 4, 2 locking for stacking kit (floor mount)

STCKKIT CST6
For STCKKIT 24EA

EA & EO SERIES | ScaleBlocker® and Field-Installed Accessories

Extend the life of your equipment with Vulcan ScaleBlocker® Water System.

ScaleBlocker® is recommended for steamers and boilers to help minimize limescale buildup and corrosion, which can dramatically affect the operation of your equipment, resulting in downtime or service calls. It's a safe and economical way to maintain your investment.



DESCRIPTION	ITEM #	FOR
SCALEBLOCKER® SYSTEM ScaleBlocker® Water Filtration System includes housing, cartridge, o-rings and water hardness test kit	SMF600 SYSTEM	Counter steamers



REPLACEMENT KIT ScaleBlocker® Kit includes cartridge and one 14oz ScaleRelease™ deliming agent bag. <i>Individual ScaleRelease bags can be purchased from Hobart Parts, or your local supplier.</i>	SMF600 PMKIT	SMF600 Systems only
---	---------------------	---------------------



HOSE(S) Flex S/S water connection 72", 3/4 GHT on both ends, per each, 2 required	HOSEWTR 3/4BBV	SMF600 Systems
--	-----------------------	----------------







HEAT SHIELD Heat deflector to protect unit from high temperature equipment	CTOPHTE SHIELD	C24EA3 or 5 PLUS C24EA3 or 5 PS C24EA3 or 5 LWE C24EO3 or 5 Boilerless
--	-----------------------	---



LEGS 4" Legs, set of 4, with adjustable foot	CNTLEGS 4INCH	C24EA3 or 5 PLUS C24EA3 or 5 PS C24EA3 or 5 LWE C24EO3 or 5 Boilerless
--	----------------------	---

EA & EO SERIES | Plug configurations and Factory-Installed Options

PLUG CONFIGURATIONS

Item #	Description	For			
		EA Plus	PowerSteam™	LWE	EO/Boilerless
 CORDPLG 3PAN1P	6' Cord and plug set rated to 45 Amps, 208-240V, 1 Phase ; cable 8/3 90C UL*; angled plug HBL9462C NEMA 14-60P	C24EA3 PLUS	C24EA3 PS	C24EA3 LWE	C24EO3
 CORDPLG 3PAN3P	6' Cord and plug set rated to 40 Amps, 208-240V, 3 Phase ; cable 8/4 90C UL*; angled plug HBL8462C NEMA 15-60P	C24EA3 PLUS	C24EA3 PS	C24EA3 LWE	C24EO3
 CORDPLG 5PAN3P	6' Cord and plug set rated to 55 Amps, 208-240V, 3 Phase ; cable 6/4 90C UL*; angled plug HBL8462C NEMA 15-60P	C24EA3 PLUS C24EA5 PLUS	C24EA3 PS C24EA5 PS	C24EA3 LWE C24EA5 LWE	C24EO5
 CORDPLG 5P480	6' Cord and plug set rated to 30 Amps, 480V, 3 Phase ; cable 8/4 90C UL*; straight plug HBL2731 NEMA L16-30P	C24EA5 PLUS	C24EA5 PS	C24EA5 LWE	C24EO5

*UL classification (SOW, SOOW, SEO and SEOW)

FACTORY-INSTALLED OPTIONS

Electrical Options	For			
	EA Plus	PowerSteam™	LWE	EO/Boilerless
480V, 60 Hz, 3 Phase	C24EA3 PLUS C24EA5 PLUS	C24EA3 PS C24EA5 PS	N/A	C24EO5/12kW
380V, 3 Phase	C24EA3 PLUS C24EA5 PLUS	C24EA3 PS C24EA5 PS	C24EA3 LWE C24EA5 LWE	C24EO5
415V, 3 Phase	C24EA3 PLUS C24EA5 PLUS	C24EA3 PS C24EA5 PS	C24EA3 LWE C24EA5 LWE	C24EO5
440V, 3 Phase	C24EA3 PLUS C24EA5 PLUS	C24EA3 PS C24EA5 PS	C24EA3 LWE C24EA5 LWE	C24EO5
Security Package				
C24CT-PPS				
Security screws, tack welds, and controls protected by lockable cover (lock by others)	C24EA3 PLUS C24EA5 PLUS	C24EA3 PS C24EA5 PS	C24EA3 LWE C24EA5 LWE	C24EO3 C24EO5

ET SERIES | *Powerful, Durable and Efficient*

Accelerate your kitchen with faster startup and continuous steam generation for nonstop cooking performance with Smart Fill technology.

STANDARD FEATURES:

- Professional controls with 60-minute timer, buzzer, cook/ready lights, power switch, and constant stream feature.
- Stainless steel exterior and cooking compartments with coved interior corners.
- Heavy duty door and latch mechanism.
- Long-life door gasket with exclusive Vulcan pan guard.
- Dual water line connection.
- External delimiting port.
- High output stainless steel mineral -tolerant dual generators.
- Twin generators with independent cooking control.



C24ET10
10-Pan Capacity

ET SERIES | CABINET BASE - ELECTRIC

Model	Pan Capacity *	Input	Standard Power Supply
C24ET6	6	17 kW	208V, 60 Hz, 3 Phase
C24ET10	10	30 kW	208V, 60 Hz, 3 Phase

ET is Dual Generator. Can be field converted to: 208V, 60-50 Hz, 1 Phase | 240V, 60-50 Hz, 3 Phase | 240V, 60-50 Hz, 1 Phase.

**12" x 20" x 2½" Pan*

ET SERIES - POWERSTEAM™ | *The Faster High-Volume Production Floor Steamer*

Cook up to 20% faster with superheated steam, allowing kitchens to increase throughput and turn tables more efficiently.

STANDARD FEATURES:

- Superheated 235°F high-energy steam.
- Staged water fill for superior heat-up and steam quality.
- Professional controls with 60-minute timer, buzzer, cook/ready lights, power switch, and constant stream feature.
- Stainless steel exterior and cooking compartments with coved interior corners.
- Heavy duty door and latch mechanism.
- Long-life door gasket with exclusive Vulcan pan guard.
- Dual water line connection.
- External delimiting port.
- High output stainless steel mineral-tolerant dual generators.



C24ET PS
6 - & 10-Pan Capacity

ET SERIES - POWERSTEAM™ TECHNOLOGY | CABINET BASE - ELECTRIC

Model	Pan Capacity*	Input	Standard Power Supply
C24ET6 PS	6	18.2 kW	208V, 60 Hz, 3 Phase
C24ET10 PS	10	31.2 kW	208V, 60 Hz, 3 Phase

- *Can be field converted to: 208V, 60-50 Hz, 1 Phase | 240V, 60-50 Hz, 3 Phase | 240V, 60-50 Hz, 1 Phase.*
- *Available with optional propane.*
- **12" x 20" x 2½" Pan*



ET SERIES - LWE | *Powerful, Durable and Efficient*

STANDARD FEATURES:

- Uses 90% less water versus traditional models, while maintaining cook time.
- Twin generators with independent cooking control.
- Stainless steel exterior and cooking compartments with coved interior corners.
- Cook multiple foods without flavor transfer.
- ENERGY STAR® certified and uses 50% less energy versus traditional models.



C24ET10 LWE
10-Pan Capacity

ET SERIES - LWE TECHNOLOGY | CABINET BASE - ELECTRIC

Model	Pan Capacity*	Input	Standard Power Supply
C24ET6 LWE	6	17 kW	208V, 60 Hz, 3 Phase
C24ET10 LWE	10	30 kW	208V, 60 Hz, 3 Phase

Can be field converted to: 208V, 60-50 Hz, 3 Phase. This unit is not available in 1 Phase or 480V.

*12" x 20" x 2½" Pan

GA SERIES / GA SERIES - POWERSTEAM™

STANDARD FEATURES:

- Professional controls with 60-minute timer, buzzer, cook/ready lights, power switch, and constant stream feature.
- Stainless steel exterior and cooking compartments with coved interior corners.
- Heavy duty door and latch mechanism.
- Long-life door gasket with exclusive Vulcan pan guard.
- Dual water line connection.
- 115V cord and plug for control operation.



C24GA10
10-Pan Capacity

GA SERIES | CABINET BASE - GAS

Model	Pan Capacity*	Input	Standard Power Supply
C24GA6	6	125,000 BTU/hr	208V, 60 Hz, 3 Phase
C24GA10	10	125,000 BTU/hr	208V, 60 Hz, 3 Phase

- Can be field converted to: 208V, 60-50 Hz, 1 Phase | 240V, 60-50 Hz, 3 Phase | 240V, 60-50 Hz, 1 Phase.
- Available with optional propane.
- *12" x 20" x 2½" Pan

Same standard features on GA Series, but with added superheated 235°F high-energy steam:

GA SERIES - POWERSTEAM™ TECHNOLOGY | CABINET BASE - GAS

Model	Pan Capacity*	Input	Standard Power Supply
C24GA6 PS	6	125,000 BTU/hr	208V, 60 Hz, 3 Phase
C24GA10 PS	10	125,000 BTU/hr	208V, 60 Hz, 3 Phase

- Can be field converted to: 208V, 60-50 Hz, 1 Phase | 240V, 60-50 Hz, 3 Phase | 240V, 60-50 Hz, 1 Phase.
- Available with optional propane.
- *12" x 20" x 2½" Pan



C24GA10 PS
10-Pan Capacity

DA SERIES - DIRECT STEAM

STANDARD FEATURES:

- Professional controls with 60-minute timer, buzzer, cook/ready lights, power switch, and constant stream feature.
- Stainless steel exterior and cooking compartments with coved interior corners.
- Heavy duty door and latch mechanism.
- Long-life door gasket with exclusive Vulcan pan guard.
- Water line connection for condensation.
- 115V cord and plug for control operation.
- Potable steam source required.



C24DA10
10-Pan Capacity

DA SERIES (POTABLE/CLEAN STEAM) | CABINET BASE - DIRECT STEAM

Model	Pan Capacity*	Input	Standard Power Supply
C24DA10	10	4 BHP	208V, 60 Hz, 3 Phase

- Potable steam source required.
- *12" x 20" x 2½" Pan

FLOOR STEAMERS | *Field-Installed Accessories and Factory-Installed Options*

FIELD-INSTALLED ACCESSORIES

HEAT SHIELD

Heat deflector for control side



CSTMHTE SHIELD
For all floor steamer models

QUICK DISCONNECT HOSE

3/4" x 4' quick disconnect hose with restraining device



3/4QD-HOSE-4
For all gas steamers

WATER FILTRATION

ScaleBlocker® Water Filtration System

SMF620 SYSTEM

For all floor steamer models



ScaleBlocker® Kit includes cartridge & ScaleRelease™

SMF620 PMKIT

For SMF620 SYSTEM



Flex S/S water connection 72", 3/4 GHT on both ends, per each, 2 required

HOSEWTR 3/4BBV

For SMF600 SYSTEM



FACTORY-INSTALLED OPTIONS

Electrical Options:

220V, 60 Hz, 1 Phase

ET Base

N/A

PowerSteam™

C24GA6 PS
C24GA10 PS

LWE

N/A

GA

C24GA6
C24GA10

480V, 60 Hz, 3 Phase

C24ET6
C24ET10

C24ET6 PS
C24ET10 PS

N/A

N/A

380V, 3 Phase

N/A

C24ET6 PS
C24ET10 PS

N/A

N/A

415V, 3 Phase

N/A

C24ET6 PS
C24ET10 PS

N/A

N/A

440V, 3 Phase

N/A

C24ET6 PS
C24ET10 PS

N/A

N/A

Security Package:

C24CT-PPS

Security screws, tack welds and controls protected by lockable cover (lock by others)

C24ET6
C24ET10

C24GA6 PS
C24GA10 PS

C24ET6 LWE
C24ET10 LWE

C24GA6
C24GA10

SCALEBLOCKER® WATER FILTRATION SYSTEM

ScaleBlocker® is recommended for steamers to help minimize limescale buildup and corrosion, which can dramatically affect the operation of your steamer or boiler and result in downtime or service calls. It's a safe and economical way to maintain your Vulcan steam equipment.



- Remove problems from water without adding harmful chemicals or additives
- 5 micron filter for removal of particulate matter
- Control alkalinity and pH

- Protect flavor and aroma
- Remove chlorine and chloramines
- Certified to NSF standards 42 and 53

FOR ALL FLOOR STEAMER MODELS



SMF620 SYSTEM
Filtration System includes housing, cartridge, o-rings and water hardness test kit

FOR ALL COUNTER STEAMER MODELS



SMF600 SYSTEM
Filtration System includes housing, cartridge, o-rings and water hardness test kit



SMF620 PMKIT
ScaleBlocker® Kit includes cartridge and two 14oz ScaleRelease™ deliming agent bags. *Individual ScaleRelease bags can be purchased from Hobart Parts, or your local supplier.*



SMF600 PMKIT
ScaleBlocker® Kit includes cartridge and one 14oz ScaleRelease™ deliming agent bag. *Individual ScaleRelease bags can be purchased from Hobart Parts, or your local supplier.*

Contact your Vulcan Representative for more details. Generator based steamers should be delimed on a regular basis. This is in accordance with the minimum preventive maintenance schedule required by the Warranty. Delimer can be purchased through Hobart or your local dealer. READ AND FOLLOW THE INSTRUCTIONS ON THE DELIMING MATERIAL PACKAGE. See Vulcan's Limited Original Commercial Equipment Warranty (F45416) for details on the 1st-year Warranty and 2nd-year Extended Warranty that may apply to Vulcan Steamers with ScaleBlocker® water systems. All terms of such Warranty are incorporated herein by reference.

PRECIPAN™ INTELLIGENT BRAISING PAN | *Smart. Precise. Multifunctional.*

Do more with less equipment. Boil, braise, sauté, sear, and more at the touch of a button — and clean with ease. PreciPan™ saves space under your hood, increases production, and reduces training costs.



Model VPP40E shown with included strainer

- **PRECISION COOKING**

Temperature-controlled multizone cooking, accurate water metering, and pre-programmed recipes take the guess work out of cooking.

The optional food probe enables food to be cooked by 'time' or 'target core temp'.

Convenient USB port for loading recipes.

- **MULTIZONE COOKING**

Multiple heat zones with accurate temperature control allow you to cook multiple items, at different temperatures and different times.

Model VPP28E (28 gal) features 2 heat zones

Model VPP40E (40 gal) features 3 heat zones

- **AUTOMATIC EASE** Cut time and labor while increasing quality and productivity.



Auto Lift:
Add optional baskets to easily cook pasta, retherm, and more



Auto Tilt:
Dispense with precision and ease



Auto Drain:
Tilt-free draining

- **EASY TO USE CONTROLS**

Large touch screen, convenient knob, and intuitive menu simplify training and cooking.



AUTO, MANUAL & TOOLBOX MENUS

- Access **pre-programmed recipes library**, load new ones, and create favorites for consistent results time and again.
- **Semi-Automatic Cleaning:** Auto fills and prompts users through the cleaning process for simple clean up.
- **Tools & Resources:** User manual, service information, diagnostics and more.



BRAISING PANS

PRECIPAN™ INTELLIGENT BRAISING PAN | *Smart. Precise. Multifunctional.*

STANDARD FEATURES:

- Boil faster with rapid heat transfer — double the power of traditional braising pans.
- Multi-zone temperature controlled cooking.
- Visual display of set and actual temperature, 80-482°F.
- Continuous timers (up to six) tracks up to 99:00 minutes and seconds. Set, remaining or count time displayed.
- Automatic water filling to specific preset volumes or a desired manual selection, including audible prompt to alert when completed.
- Embossed gallon and liter markings.
- Auto drain allows controlled powered drain allows operators to drain without tilting.
- Motor driven pan tilt/lift and a wide pour path ensures rapid and controlled emptying with minimal pour area.
- Guided simple cleaning and retractable spray hose.
- Custom settings allow for user personalization, interactive service diagnostics, data collection and operator instructions.
- Automatic preheat function.
- Lid stops in place for vented cooking.
- USB port and multi point food probe socket.
- Auto-lift arm and stainless steel wire hanging basket(s) (2 for VPP28, 3 for VPP40).
- One-year limited parts and labor warranty (two-year for K-12).



Model VPP28E shown with included strainer and baskets

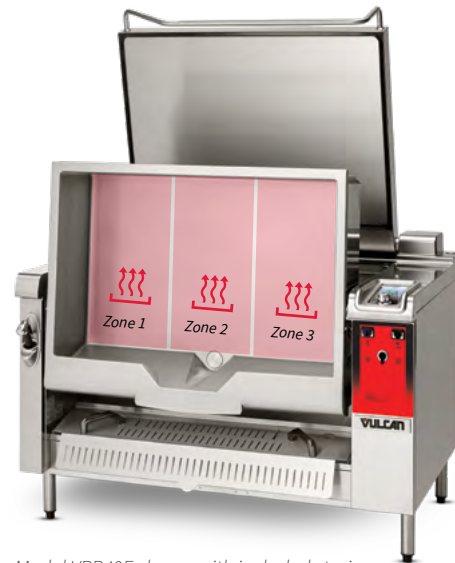

Model VPP40E shown with included strainer

PRECIPAN | ELECTRIC

Model	True Working Capacity	Dimensions (WxDxH)	Voltage/Phase	Frequency	kW	Amps
VPP28E-208	28 Gal	43.3" x 38.3" x 39.4"	208/3	60 Hz	22.8 kW	63.3
VPP28E-240	28 Gal	43.3" x 38.3" x 39.4"	240/3	60 Hz	20.9 kW	50.4
VPP28E-480	28 Gal	43.3" x 38.3" x 39.4"	480/3	60 Hz	27.9 kW	33.6
VPP40E-208	40 Gal	55.1" x 38.3" x 39.4"	208/3	60 Hz	34.2 kW	95
VPP40E-240	40 Gal	55.1" x 38.3" x 39.4"	240/3	60 Hz	31.4 kW	75.6
VPP40E-480	40 Gal	55.1" x 38.3" x 39.4"	480/3	60 Hz	41.9 kW	50.3

PRECIPAN™ | *Field-Installed Accessories*



DESCRIPTION

PROBE

Multi-point temperature probe allows cooking by internal temperature; conveniently attaches to front panel

ITEM

V-PROBE

FOR

All models



BASKET

Extra stainless steel wire hanging basket

VPP-BASKET

All models



CART

Assists with transporting batches of food or waste; includes 4 casters with locks; holds 2 hotel pans (not included)

VPP-CART

All models



BACK PANEL

Stainless steel enclosure provides protection of mechanical elements

VPP-BACK28
VPP-BACK40

VPP28 models
VPP40 models

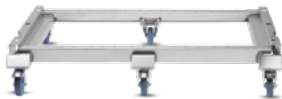

CASTERS

Caster frame kit allows PreciPan to easily move; includes heavy duty locking front casters and frame

VPP-CASTER28
VPP-CASTER40

VPP28 models
VPP40 models



RACK

Stainless steel rack for assisting with steaming by placing pans on rack

VPP-BASEPLATE

All models



SCRAPER

Stainless steel food scraper (spatula) to help aid in flipping and scraping food in pan

VPP-SCRAPER

All models



BRAISING PANS

V SERIES BRAISING PANS | *Braise, Sauté, Simmer, Pan Fry, Grill, and More*

Braising pans are among the most versatile pieces of cooking equipment - perfect for sautéing or steaming vegetables, browning roasts, grilling burgers, and much more. With Vulcan's FastBatch(TM) Technology, our VE Series Electric Braising Pans heat up approximately 20% faster than previous models, maximizing efficiency and performance.

STANDARD FEATURES:

- Electric models equipped with FastBatch™ heating technology.
- Stainless steel exterior, frame, and flanged feet.
- Stainless steel pan with embossed gallon markings and pouring lip strainer.
- Watertight controls and enclosure.
- Electronic ignition (gas models.)
- Stainless steel hinged cover with drip edge. *Use of the cover will reduce heat-up time by 50%*
- Stainless steel drop-down food receiving pan support.
- Solid state temperature controls adjust from 50–425°F.
- “L” faucet bracket adds 3" to width, field-installed left or right side.
- True working capacity.



VG40
shown with Catch Can



VG40

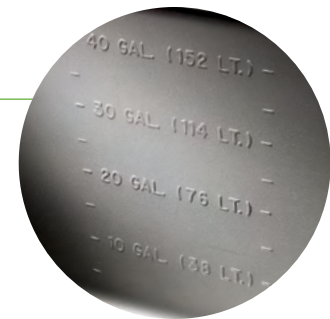

Embossed gallon/liter markings increase ease of use, improve accuracy of measurements, and won't wear off over time.

V SERIES | ELECTRIC & GAS

Model	True Working Capacity	Dimensions (WxD)	Input
ELECTRIC			
VE30	30 Gal	36" x 35½"	12 kW
VE40	40 Gal	46" x 35½"	16 kW
GAS			
VG30	30 Gal	36" x 35½"	90,000 BTU/hr
VG40	40 Gal	46" x 35½"	120,000 BTU/hr

Available with optional propane.

V SERIES BRAISING PANS | *Factory-Installed Options*

Item #

Draw-off valves:

A draw-off valve is ideal for removing waste (such as fat) during cooking or cleaning up; use the Catch Can to facilitate draining the waste when using the draw-off valve.

BPDOV-1 (2") Draw-off valve — left front, straight, with strainer; **pan support not available on 30-gallon**

BPDOV-2 (2") Draw-off valve — left front, 90° left, with strainer; **pan support not available on 30-gallon**

BPDOV-3 (2") Draw-off valve — left side, 90° front, with strainer

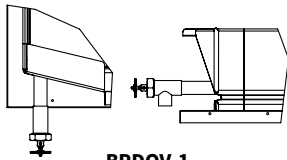

BPDOV-1
left front, straight

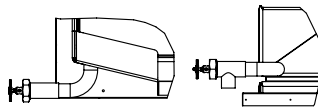

BPDOV-2
left front, 90° left

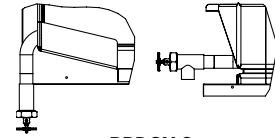

BPDOV-3
left side, 90° front

Security features:

BP-PPS Security screws, tack welds, heavy gauge chain, securing crank handle and pan strainer, controls protected by lockable cover (lock by others), perforated flue cover (gas models only) or perforated lid support cover (electric models only)

BPDOV-PPS Heavy gauge chain securing draw-off valve and chain

Electrical Options:

- 220V, 50-60 Hz, 1 Phase (Gas)
- 480V, 60 Hz, 3 Phase (3 Wire)
- 380V, 3 Phase (3 Wire)
- 415V, 3 Phase (3 Wire)
- 440V, 3 Phase (3 Wire)

Mechanical Option:

Motorized Pan Lift



BP-PPS
Security package



BPDOV-PPS
Heavy gauge chain

COMPATIBLE FAUCETS



SGLTS 18NZLJ



DBLTS 18NZLJ



DBLPTS POTFIL



DBFCTTS WSHDWN



DBPTYTS WSHDWN

V SERIES BRAISING PANS | *Field-Installed Accessories*



DESCRIPTION

CATCH CAN

Catch can with bail handle and drain hose (1" ID x 48" length) draw-off valve

ITEM

CATCH CAN

FOR

All models with draw-off valve



DRAIN PAN

Drain pan and hose (1½" x 7/8" ID food grade 36" length)

20X4 DRNPAN

All models



STEAM PAN INSERT

Steam pan insert (pan not included)

BPSTEAM INSERT

All models



BOILING BASKET

Stainless steel perforated boiling basket (12" x 20" x 6" deep) with handles

BOILING BASKET

All models



CASTERS

Set of 4 adjustable casters with 2 locking, 4" wheels

CASTERS BP

All models





QUICK DISCONNECT HOSE

¾" x 4' quick disconnect hose with restraining device

3/4QD-HOSE-4

All gas models

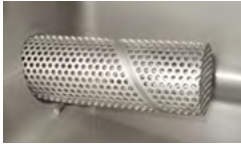
V SERIES BRAISING PANS | *Field-Installed Accessories*

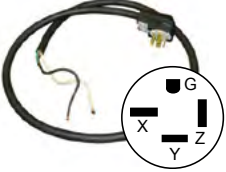
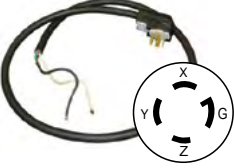
	DESCRIPTION	ITEM #	FOR
	<p>STRAINER Draw-off strainer <i>Supplied when unit is ordered with a drawoff</i></p>	STRAINR BPDOV	All models
	<p>FAUCET BRACKET Enclosed box faucet bracket; adds 3"</p>	FCTBRKT BP	All models
	<p>CORD AND PLUG SET 6' Cord and plug set rated to 55 Amps, 208-240V, 3 Phase; cable 6/4 90C UL*; angled plug HBL8462C NEMA 15-60P <i>*UL classification (SOW, SOOW, SEO and SEOW).</i></p>	CORDPLG 5PAN3P	VE30 & VE40
	<p>CORD AND PLUG SET 6' Cord and plug set rated to 30 Amps, 480V, 3 Phase; cable 8/4 90C UL*; straight plug HBL2731 NEMA L16-30P <i>*UL classification (SOW, SOOW, SEO and SEOW).</i></p>	CORDPLG 5P480	VE30 & VE40

K SERIES - GAS FLOOR MOUNTED | *Ellipsoidal Bottom for Superior Heat Transfer*

TILTING MODEL STANDARD FEATURES:

- True working capacity.
- Motorized tilt (standard on gas, optional on electric models).
- Embossed gallon/liter markings.
- Heavy bar rim
 $\frac{1}{4}$ " x $\frac{5}{8}$ " 20-gallon
 $\frac{3}{8}$ " x 1" 40- or 60-gallon
- Splash-proof housing with on/off switch and intuitive warm/simmer/boil control.
- Faucet bracket.
- High-efficiency gas power burner with electronic ignition.
- 115V cord and 3 prong plug (gas only).
- 316 stainless steel liner.

STATIONARY MODEL STANDARD FEATURES:

Same features as tilting, plus:

- 2" compression draw-off valve with perforated strainer.
- Spring assist cover with condensate ring.



K40GL

Stationary model shown with optional DOV PLUG2 draw-off valve.

K SERIES GAS | STATIONARY & TILTING MODELS

Model	True Working Capacity	Input
STATIONARY		
K40GL	40 Gal	100,000 BTU/hr
K60GL	60 Gal	100,000 BTU/hr
TILTING		
K20GLT	20 Gal	100,000 BTU/hr
K40GLT	40 Gal	100,000 BTU/hr
K60GLT	60 Gal	100,000 BTU/hr

Spring assist cover is an accessory for tilting kettles.



K40GLT

Tilting model shown with optional DOV PLUG2 draw-off valve.

COMPATIBLE FAUCETS



SGLTS 18NZLJ



DBLTS 18NZLJ



DBLPPTS POTFIL



DBFCTTS WSHDWN



DBPTYTS WSHDWN

KETTLES - 2/3 JACKETED

K SERIES - ELECTRIC FLOOR MOUNTED | *Ellipsoidal Bottom for Superior Heat Transfer*

TILTING MODEL STANDARD FEATURES:

- True working capacity.
- Motorized tilt (standard on gas, optional on electric models).
- Embossed gallon/liter markings.
- Heavy bar rim
 $\frac{3}{4}$ " x $\frac{5}{8}$ " 20-gallon
 $\frac{3}{8}$ " x 1" 40- or 60-gallon
- Splash-proof housing with on/off switch and intuitive warm/simmer/boil control.
- Faucet bracket.
- High-efficiency gas power burner with electronic ignition.
- 316 stainless steel liner.

STATIONARY MODEL STANDARD FEATURES:

Same features as tilting, plus:

- 2" compression draw-off valve with perforated strainer.
- Spring assist cover with condensate ring.



K40EL
Stationary model

K SERIES ELECTRIC | STATIONARY & TILTING MODELS

Model	True Working Capacity	Input
STATIONARY		
K40EL	40 Gal	18 kW
K60EL	60 Gal	18 kW
TILTING		
K20ELT	20 Gal	12 kW
K40ELT	40 Gal	18 kW
K60ELT	60 Gal	18 kW

Spring assist cover is an accessory for tilting kettles.



K40ELT
Tilting model shown with
SUPPORT PAN accessory

COMPATIBLE FAUCETS



K SERIES - DIRECT STEAM FLOOR MOUNTED

STANDARD FEATURES:

- True working capacity.
- Embossed gallon/liter markings.
- Heavy bar rim
 $\frac{1}{4}$ " x $\frac{3}{8}$ " 20-gallon
 $\frac{3}{8}$ " x 1" 40- or 60-gallon
- Splash-proof housing with on/off switch and intuitive warm/simmer/boil control.
- Faucet bracket.
- 316 stainless steel liner.
- Steam control assembly including inlet globe valve and steam trap, condensate strainer and check valve.



K40ELT

K SERIES DIRECT STEAM | TILTING MODELS

Model	True Working Capacity	Input
K20DLT	20 Gal	1 BHP
K40DLT	40 Gal	1.5 BHP
K60DLT	60 Gal	2.3 BHP

Spring assist cover is an accessory for tilting kettles.

GALLONS MARKING

6 GAL	2, 3, 4, 5, 6
12 GAL	6, 8, 10, 12
20 GAL	10, 12, 14, 16, 18, 20
40 GAL	15, 20, 25, 30, 35, 40
60 GAL	20, 25, 35, 40, 45, 50, 55, 60



COMPATIBLE FAUCETS



SGLTS 18NZLJ



DBLTS 18NZLJ



DBLPOTS POTFIL



DBFCTTS WSHDWN



DBPTYTS WSHDWN

K SERIES - FLOOR MOUNTED | *Factory-Installed Options*

ALL ELECTRIC MODEL FACTORY-INSTALLED OPTIONS:

- 220V, 50-60 Hz, 1 Phase (Gas)
- 480V, 60 Hz, 3 Phase (3 Wire)
- 380V, 3 Phase
- 415V, 3 Phase
- 440V, 3 Phase

STATIONARY KETTLES ONLY | FACTORY-INSTALLED OPTIONS:

- | | |
|--------------------|--|
| SK-PPS | Security Features:
Electric and gas stationary kettle security screws, tack welds and controls protected by lockable cover (lock by others); Draw-off valve secured with chain; perforated flue cover (gas only) |
| SKD-PPS | Direct stationary steam kettle security screws, tack welds, draw-off valve secured with chain |
| LKCOVER-PPS | Cover with lock hasp, lock by others |
| SKDOV PPS | Protection for draw-off valve for K Series Stationary Kettles |
| | Draw-off Valves: |
| KDOV COMP3* | Compression draw-off valve, 3" in lieu of standard 2" valve |
| KDOV PLUG2 | Plug draw-off valve, 2" in lieu of standard 2" valve |



Control Panel Cover



SKDOV PPS

TILTING KETTLES ONLY | FACTORY-INSTALLED OPTIONS:

- | | |
|-----------------------|--|
| TK-PPS | Security Features:
Electric and gas tilting kettle without draw-off valve; security screws, tack welds and controls protected by lockable cover (lock by others); tilting handle secured with chain; perforated flue cover |
| TKD-PPS | Direct stationary steam kettle without draw-off valve; security screws, tack welds |
| KDOV CHAIN-PPS | Draw-off valve secured with chain only |
| TKDOV PPS | Protection for draw-off valve for K Series with chain |
| | Draw-off Valves: |
| KTDOV COMP2 | Compression draw-off valve, 2" with perforated strainer |
| KTDOV COMP3* | Compression draw-off valve, 3" with perforated strainer* |
| KTDOV PLUG2 | Plug draw-off valve, 2" with perforated strainer |

*20-gallon kettle not available with 3" draw-off valve.



2" Compression



3" Compression



2" Plug





K SERIES - FLOOR MOUNTED | *Field-Installed Accessories*

	DESCRIPTION	ITEM #	FOR
	PERFORATED STRAINER Perforated strainer for draw-off valve <i>Supplied with all kettles that have a drawoff</i>	STRAINR DPS20 STRAINR DPS40 STRAINR DPS60	K20 K40 K60
	SOLID DISK Solid disk for draw-off valve	STRAINR DSS20 STRAINR DSS40 STRAINR DSS60	K20 K40 K60
	STRAINER Tilting kettle pouring lip strainer	STRAINR K20 STRAINR K40 STRAINR K60	20 gal models 40 gal models 60 gal models
	LIFT-OFF COVER Stainless steel lift-off cover	COVER K20	20 gal models
	DRAIN PAN Drain pan and hose (1½" x 7/8" ID food grade 36" length)	20X4 DRNPAN	K Series Tilting Kettles
	SUPPORT PAN Stainless steel food receiving pan support	SUPPORT PAN SUPPORT PANGLT	Electric and direct steam K Series tilting Gas K Series tilting kettles
	HINGED COVERS for K series tilting kettles	SACOVER K20DLT SACOVER K40DLT SACOVER K60DLT SACOVER K20ELT SACOVER K40ELT SACOVER K60ELT SACOVER K20GLT SACOVER K40GLT SACOVER K60GLT	K20DLT K40DLT K60DLT K20ELT K40ELT K60ELT K20GLT K40GLT K60GLT

KETTLES - 2/3 JACKETED



K SERIES - FLOOR MOUNTED | *Field-Installed Accessories*

	DESCRIPTION	ITEM #	FOR
	<p>PADDLE SCRAPER Paddle scraper with 48" handle with nylon blade</p>	<p>PADDLE 48</p>	<p>All models</p>
	<p>WHIP Stainless steel 48" whip</p>	<p>SSTWHIP 48</p>	<p>All models</p>
	<p>CATCH CAN Catch can with bail handle and drain hose (1" ID x 48" length) for draw-off valve</p>	<p>CATCH CAN</p>	<p>All models with DOV</p>
	<p>QUICK DISCONNECT HOSE 3/4" x 4' quick disconnect hose with restraining device</p>	<p>3/4QD-HOSE-4</p>	<p>All gas models</p>
	<p>CLEANING KIT Includes draw-off brush, clean-up brush with 36" handle, and paddle scraper with 40" handle</p>	<p>CLEANUP KIT</p>	<p>All models</p>

K SERIES - TILTING COUNTER & FLOOR | *Easy-to-Use Operator Controls*

STANDARD FEATURES:

- True working capacity.
- Embossed gallon/liter markings.
- Heavy bar rim ¼" x ⅝".
- Faucet bracket.
- 316 stainless steel liner.
- Splash-proof housing with on/off switch and intuitive warm/simmer/boil control.



K6ETT



K12ETT



K20ETT

K SERIES ELECTRIC | TILTING COUNTER MODELS

Model	True Working Capacity	Input kW	Standard Power Supply
K6ETT	6 Gal / 24 Qts	7.5 kW /10kW	208/240V, 50-60 Hz, 3 Phase
K12ETT	12 Gal / 48 Qts	12 kW/16kW	208/240V, 50-60 Hz, 3 Phase

Can be field converted to: 208V, 60-50 Hz, 1 Phase | 240V, 60-50 Hz, 3 Phase | 240V, 60-50 Hz, 1 Phase.

K SERIES ELECTRIC | TILTING FLOOR MODELS

Model	True Working Capacity	Input kW	Standard Power Supply
K20ETT	20 Gal / 80 Qts	12 kW/16kW	208/240V, 50-60 Hz, 3 Phase

Can be field converted to: 208V, 60-50 Hz, 1 Phase | 240V, 60-50 Hz, 3 Phase | 240V, 60-50 Hz, 1 Phase.

GALLONS MARKING

6 GAL	2, 3, 4, 5, 6
12 GAL	6, 8, 10, 12
20 GAL	10, 12, 14, 16, 18, 20

COMPATIBLE FAUCETS



SGLTS 18NZLJ



DBLTS 18NZLJ



DBLPOTS POTFIL

K SERIES - TILTING COUNTER & FLOOR | *Field-Installed Accessories*

FIELD-INSTALLED ACCESSORIES

TILTING KETTLE STRAINERS

Strainer for tilting kettles



STRAINR K6 K6ETT
STRAINR K12 K12ETT
STRAINR K20 K20ETT

COVERS

Stainless steel lift-off cover with lid hanger



COVER K6 K6ETT
COVER K12 K12ETT
COVER K20 K20ETT

STANDS

Stainless steel stand with flanged feet for electric kettle with sliding drain pan







STAND VSKT30
 K6ETT, K12ETT

Economy stand for electric kettle without sliding drain pan



STAND VSKTEC
 K6ETT, K12ETT

Item #	Description	For
CORDPLG 3PAN1P 	6' Cord and plug set rated to 45 Amps, 208-240V, 1 Phase ; cable 8/3 90C UL*; angled plug HBL9462C NEMA 14-60P	K6ETT
CORDPLG 3PAN3P 	6' Cord and plug set rated to 40 Amps, 208-240V, 3 Phase ; cable 8/4 90C UL*; angled plug HBL8462C NEMA 15-60P	K6ETT
CORDPLG 5PAN3P 	6' Cord and plug set rated to 55 Amps, 208-240V, 3 Phase ; cable 6/4 90C UL*; angled plug HBL8462C NEMA 15-60P	K12ETT K20ETT
CORDPLG 5P480 	6' Cord and plug set rated to 30 Amps, 480V, 3 Phase ; cable 8/4 90C UL*; straight plug HBL2731 NEMA L16-30P	K6ETT K12ETT, K20ETT

*UL classification (SOW, SOOW, SEO and SEOW).

FACTORY-INSTALLED OPTIONS

Code	Security Option:	For
KETT-PPS	Security fasteners and tack welds with controls protected by lockable cover (lock by others)	K6ETT, K12ETT, K20ETT
	Electric Options:	
	480V, 60 Hz, 3 Phase	K6ETT(7.5 kW), K12ETT(12 kW), K20ETT(12 kW)
	380V, 3 Phase	K6ETT, K12ETT, K20ETT
	415V, 3 Phase	K6ETT, K12ETT, K20ETT
	440V, 3 Phase	K6ETT, K12ETT, K20ETT

VEKT SERIES | SPEC LINE TILTING KETTLE / TABLE COMBO

STANDARD FEATURES:

- Stainless steel exterior, legs, and flanged feet.
- Heavy gauge top with formed drain trough.
- Sliding drain pan.
- Embossed gallon/liter markings.



VEKT80/666
shown with DBLTS 18NZLJ faucets

SPEC LINE TABLES

Model	Included Kettle	True Working Capacity	Width	Input
1 KETTLE				
VEKT26/6	(1) K6ETT	6 Gal / 24 Qts	26"	7.5 kW
2 KETTLES				
VEKT50/66	(2) K6ETT	12 Gal / 48 Qts	50"	15 kW
VEKT64/612	(1) K6ETT + (1) K12ETT	18 Gal / 72 Qts	64"	19.5 kW
VEKT64/126	(1) K12ETT + (1) K6ETT	18 Gal / 72 Qts	64"	19.5 kW
VEKT64/1212	(2) K12ETT	24 Gal / 96 Qts	64"	24 kW
3 KETTLES				
VEKT80/666	(3) K6ETT	18 Gal / 72 Qts	80"	22.5 kW



VEKT26/6
shown with DBLTS 18NZLJ faucet

- Capacity equals the quantity of mounted kettle(s).
- All tables are 24" deep x 21.5" high to the tabletop.
- Refer to the specification sheet for overall height with kettles.
- Total kW equals the electric kettles mounted on the table—each machine will have separate connections. Refer to the specification sheet for electrical data.
- Kettles and tables are shipped separately for field assembly.

COMPATIBLE FAUCETS



SGLTS 12NZL



DBLTS 12NZL





SGLTS 18NZLJ



DBLTS 18NZLJ

KETTLES - 2/3 JACKETED

VEKT SERIES | *Field-Installed Accessories*

	DESCRIPTION	ITEM #	FOR
	STRAINER Strainer for tilting kettles	STRAINR K6 STRAINR K12	6-gallon models 12-gallon models
	TABLES Table with sliding drain pan	KT26 TABLE KT50 TABLE KT64 TABLE KT80 TABLE	26" 50" 64" 80"
	COVERS Stainless steel lift-off cover with lid hanger	COVER K6 COVER K12	6-gallon models 12-gallon models

FACTORY-INSTALLED OPTION

Option	For
480V, 60 Hz, 3 Phase (each kettle)	K6ETT, K12ETT
380V, 3 Phase	K6ETT, K12ETT
415V, 3 Phase	K6ETT, K12ETT
440V, 3 Phase	K6ETT, K12ETT

FULLY JACKETED | A True Workhorse for Over 50 Years — Durable, Efficient, and Reliable

STANDARD FEATURES:

- Heavy 11-gauge rim.
- Faucet bracket.
- 316 stainless steel liner.
- Sloped bottom for superior draining.
- Splash-proof housing with on/off switch and warm/simmer/boil control.
- 2" plug draw-off valve with perforated strainer.
- Spring assist cover with condensate ring.
- Heavy duty pivot assembly for kettle cover, yolk style mount with tie bar.
- Electronic ignition.
- 15 psi.

GAS KETTLES | STATIONARY

Model	Capacity	Input
GS40ES*	40 Gal	135,000 BTU/hr
GS60E	60 Gal	135,000 BTU/hr
GL80E	80 Gal	135,000 BTU/hr
GT100E	100 Gal	135,000 BTU/hr
GT150E	150 Gal	135,000 BTU/hr

*GS40ES comes as a short height configuration.

ELECTRIC KETTLES | STATIONARY





Model	Capacity	Input
EL80	80 Gal	36 kW
ET100	100 Gal	36 kW
ET150	150 Gal	36 kW

DIRECT STEAM KETTLES | STATIONARY

Model	Capacity	Input
SL80	80 Gal	3.4 BHP
ST100	100 Gal	4 BHP
ST150	150 Gal	6 BHP



FULLY JACKETED | *Field-Installed Accessories*

	DESCRIPTION	ITEM #	FOR
	PADDLE SCRAPER Paddle scraper with 48" handle with nylon blade	PADDLE 48	All models
	WHIP Stainless steel 48" whip	SSTWHIP 48	All models
	HEAT SHIELD Heat deflector	KTLGHTE SHIELD	All models
	QUICK DISCONNECT HOSE 3/4" x 4' quick disconnect hose with restraining device	3/4QD-HOSE-4	All gas models
	CLEANING KIT Includes draw-off brush, clean-up brush with 36" handle, and paddle scraper with 40" handle	CLEANUP KIT	All models

FULLY JACKETED | *Factory-Installed Accessories*

Draw-off Valve:

A draw-off valve is ideal for removing waste (such as fat) during cooking and cleaning.

FJDOV COM3 Compression draw-off valve, 3" in lieu of standard 2" valve

Electrical Options:

220V, 60 Hz, 1 Phase (Gas)	440V, 3 Phase (3 Wire)
380V, 3 Phase (3 Wire)	480V, 60 Hz, 3 Phase (3 Wire)
415V, 3 Phase (3 Wire)	

Security Features:

FJK-PPS	Electric and gas stationary kettle security screws, tack welds and controls protected by lockable cover (lock by others); perforated flue cover (gas only)
FJKD-PPS	Direct stationary steam kettle security screws, tack welds
FJKSTEP PPS	Protection for draw-off valve for FJ Series Stationary Kettles with chain
LKCOVER-PPS	Cover with lock hasp (lock by others)
HDCOVER-PPS	Heavy duty 14-gauge welded cover for stationary kettles, not spring assist
HDCOVER-SPLITLID	Heavy Duty 14-gauge 2-piece cover for stationary kettles, not spring assist



BHP CONVERSION & STEAM FLOW REQUIREMENTS

BHP CONVERSION & STEAM FLOW INFORMATION

BHP Conversion 1 BHP = Approximately 33,475 BTU* 1 BHP = Approximately 10 kW

Example: $\frac{200,000}{33,475 \text{ BTU}} \times \text{Boiler Efficiency} = \text{Delivered BHP}$ *Delivered BHP is a function of kW/BTU input and operating efficiency.

STEAM FLOW REQUIREMENTS FOR DIRECT KETTLES

Capacity	Fast Boil	Medium Boil	Stock Boil
	(30 minutes) lbs/hr	(45 minutes) lbs/hr	(60 minutes) lbs/hr
20-Gallon	48	32	24
40-Gallon	96	64	48
60-Gallon	143	96	72
80-Gallon	191	127	96

	Fast Boil	Medium Boil	Stock Boil
	(40 minutes) lbs/hr	(50 minutes) lbs/hr	(65 minutes) lbs/hr
100-Gallon	179	143	110
125-Gallon	224	179	138
150-Gallon	269	215	165

Steam flow rate at 10 psig at the kettle.

1 boiler horsepower = 34.5 lbs of steam per hour.

Heat-up time to bring 70°F water to boiling (212°F) at sea level.

MAXIMUM FLOW RATE OF DRY STEAM IN POUNDS PER HOUR

Supply Pressure	½"	¾"	1"	1¼"	1½"	2"
5 psig	20	40	70	140	210	380
10 psig	30	60	110	220	320	600
15 psig	40	80	150	290	430	N/A
20 psig	50	100	180	360	530	N/A
25 psig	60	120	220	430	N/A	N/A
30 psig	70	140	250	500	N/A	N/A
35 psig	80	160	290	570	N/A	N/A
50 psig	100	210	380	760	N/A	N/A

Based on 100' of clean iron pipe. Steam loss due to elbows, reductions, heat loss or condensing steam was not considered.

SINGLE PANTRY DECK MOUNT FAUCETS FOR KETTLES & BRAISING PANS



DESCRIPTION

12" SWIVEL SPOUT

Includes 4" and 12" riser; 2 temperatures – hot and cold
Cannot be used with KDLT, KELT, or KGLT kettles

ITEM #

SGLTS 12NZL



18" DOUBLE JOINTED SWIVEL SPOUT

Includes 4" and 12" riser; 1 temperature – hot or cold
 with increased coverage

SGLTS 18NZLJ

All faucets and fillers are NSF compliant and comply with the Reduction of Lead in Drinking Water Act.







DBPTYTS WSHDWN
 Faucet

K12ETT
 Tilting kettle



*VE30 shown with DBLTS 12NZL
 faucet and CASTERS-BP*

DOUBLE PANTRY DECK MOUNT FAUCETS FOR KETTLES & BRAISING PANS

	DESCRIPTION	ITEM #
	<p>12" SWIVEL SPOUT Includes 4" and 12" riser; 2 temperatures – hot and cold <i>Cannot be used with KDLT, KELT, KGLT Kettles</i></p>	<p>DBLTS 12NZL</p>
	<p>18" DOUBLE JOINTED SWIVEL SPOUT Includes 4" and 12" riser; 2 temperatures – hot and cold with increased coverage</p>	<p>DBLTS 18NZLJ</p>
	<p>BACKFLOW PREVENTER AND POT FILLER Includes 60" braided SST flex hose, rapid fill flexible hose; 2 temperatures – hot and cold <i>Use with auto-tilt products</i></p>	<p>DBLPTS POTFIL</p>
	<p>FAUCET WITH WASHDOWN HOSE Backflow preventer, low flow pre-rinse, spray valve with 60" raided SST flex hose; 2 temperatures – hot and cold <i>Low flow spray not recommended for filling pots</i></p>	<p>DBFCTTS WSHDWN</p>
	<p>FAUCET WITH WASHDOWN HOSE + 16" ADD-ON FAUCET Backflow preventer, low flow pre-rinse, spray valve with 60" braided SST flex hose; 2 temperatures – hot and cold <i>Use for filling pots and cleaning</i></p>	<p>DBPTYTS WSHDWN</p>

All faucets and fillers are NSF compliant and comply with the Reduction of Lead in Drinking Water Act.

COMBI LINE UP

Smarter equipment means smarter cooking - and better results you can see and taste. From perfectly cooked proteins to flawless baked goods, a Vulcan combi oven makes it easy to serve your best, faster. Choose the model that fits your kitchen and cook with confidence, precision, and intelligence.

MINIJET™



ABC



CHEF'SCOMBI™



FEATURES / SPECS	Minijet™	ABC	Chef'sCombi™
ENERGY STAR® certified	N/A	N/A	Select models
Accommodates full-sheet pans	N/A	✓	62, 102, 202
Automatic cleaning	✓	N/A	✓
Patented automatic humidity control (ABC technology)	✓	✓	✓
Programmable	✓	N/A	✓
Stackable	✓	✓	✓
Touchscreen	✓	N/A	✓
Utilities	Electric only	Electric/Gas	Electric/Gas
Ventless option	✓	N/A	Electric only
Reverse door option	✓	N/A	✓
Grease removal (GR) option	N/A	N/A	✓

STEAM GENERATOR COMBI OVENS **VULCAN**

CHEF'SCOMBI™ SERIES | *Everything You Need. Nothing You Don't.*

CHEF'S **COMBI**™ SMART. EFFICIENT. RELIABLE.

The Chef'sCombi is your all-in-one solution for smarter, more efficient cooking. Guided automation and precise climate control ensure consistent, high-quality results with less effort - every time. Its energy-saving design and intelligent cleaning system reduces costs and minimizes down time.



CHEF-101



CHEF-62

ADVANCED FEATURES. INTUITIVE OPERATION:

GlobalOS

The new standard in combi operating systems, with an interface that's customizable and intuitive.

CombiClimateControl

Advanced climate management for outstanding cooking results.

AutoClimate

Automatic humidity adjustment based on set temperature, providing optimum flavor and texture every time.

Chef'sGuide

Guided automatic cooking, ensuring consistently delicious dishes no matter who's at the controls.

CombiCare

Automatic cleaning that's fast, effective and inexpensive.

MenuMix

Smart technology that simplifies getting high-quality results from mixed loads.

CHEF'S COMBI™ SERIES | *Everything You Need. Nothing You Don't.*



CHEF-62 stacked on **CHEF-102**
shown with CHEF-STACK2E and CHEF-6NLEG2

STANDARD FEATURES:

- **Complimentary training support:** Enjoy a free 4 hour training session with a Vulcan Certified Chef anywhere in the USA with every purchase.
- **Multiple cooking capabilities:** Bake, steam, roast, grill, air-fry, retherm, proof, finish, poach, stew, low temp, defrost, cook & hold, and more.
- **Precise humidity control:** Sensor delivers precise humidity control ranging from 0-100%, even at temperatures below 212°F for perfect cooking.
- **Controls:** 10" HD touchscreen with knob control and intuitive interface adapts to fit your needs, creating efficiency in your kitchen.
- **IP5 waterproof rating:** Oven is protected against low-pressure jets of water, and safe to use.
- **Field stackable:** Increase your cooking capacity and streamline efficiency while maximizing kitchen space with easy on-site stacking.
- **Short, efficient cleaning time:** 20-minute, fast mid-day cleaning allows for more cooking time. Additional cleaning cycles available for a deeper clean.
- **Warranty:** 2-year parts and labor; 5-year limited steam generator.
- Select models are **ENERGY STAR® certified**, helping kitchens cut energy and water costs without compromising performance.

OPTIONAL FEATURES:

- Grease removal (GR) models automatically removes grease pump buildup from the drain box during cooking and transfers it to a collection container.
- Left hinge (L) models are available to complement the flow of the space or to mirror other appliances.

STEAM GENERATOR COMBI OVENS **VULCAN**

CHEF'SCOMBI™ SERIES | *Everything You Need. Nothing You Don't.*



CHEF-61



CHEF-62



CHEF-101



CHEF-102

20-Level Roll-in Combi Ovens Coming Soon!



CHEF-201
COMING SOON!



CHEF-202
COMING SOON!

CHEF'SCOMBI SERIES | GAS

Model Number	Levels	Size	BTU/hr	Amp
CHEF-61G	6	Half	51,182 BTU/hr	5.8
CHEF-101G	10	Half	85,303 BTU/hr	5.8
CHEF-201G	20	Half	170,607 BTU/hr	12
CHEF-62G	6	Full	102,364 BTU/hr	5.8
CHEF-102G	10	Full	143,310 BTU/hr	5.8
CHEF-202G	20	Full	286,620 BTU/hr	12

PAN CAPACITY (Gas & Electric Models)

Hotel Pans	Sheet Pans
6 (12"x20")	6 (13"x18")
10 (12"x20")	10 (13"x18")
20 (12"x20")	20 (13"x18")
12 (12"x20")	10 (18"x26") or 12 (13"x18")
20 (12"x20")	10 (18"x26") or 20 (13"x18")
40 (12"x20")	20 (18"x26") or 40 (13"x18")

CHEF'SCOMBI SERIES | ELECTRIC

Model Number	Levels	Size	Voltage	Imax Amps	kW	Hertz	Phase
CHEF-61E	6	Half	208 240 480	31.6 29.9 15.4	10.5 11.4 10.5	60	3
CHEF-101E	10	Half	208 240 480	53 50.1 24.7	18.3 19.8 18.3	60	3
CHEF-201E	20	Half	208 240 480	107 101 54	36 39.2 36	60	3
CHEF-62E	6	Full	208 240 480	63 59.5 29	21.9 23.8 21.9	60	3
CHEF-102E	10	Full	208 240 480	101.8 96.1 45.8	35.9 39 35.9	60	3
CHEF-202E	20	Full	208 240 480	187 177 85	64.8 70.5 64.8	60	3

CHEF'SCOMBI™ SERIES | *Field-Installed Accessories*



DIAMONDGRILL
Baking and grill tray
diamond shape
Fits all models



EGGTRAY
Eggs tray 8 holes
Fits all models



ENAMEL40
Tray granite enameled
depth 40mm
Fits all models



ENAMEL60
Tray granite enameled
depth 60mm
Fits all models



PERFTRAY1.1
Perforated baking
tray 12"x20"
Fits all models



PERFTRAY2.1
Perforated baking
tray 12"x24"
Fits CHEF-62, CHEF-102



ROAST-BAKETRAY1.1
Roasting and baking
tray 12"x20"
Fits all models



ROAST-BAKETRAY2.1
Roasting and baking
tray 20"x24"
Fits CHEF-62, CHEF-102

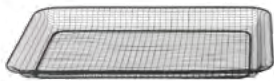

FRYBASKET
Frying baskets coated
with DURAPEK
Fits all models

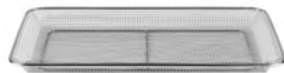

1220-BASKET
Stainless steel fry
basket 12"x20"
Fits all models

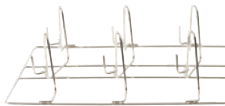

CHICKRACK6
Stainless steel
(6) chicken rack
Fits all models

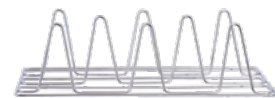

CHICKRACK8
Stainless steel
(8) chicken rack
Fits all models

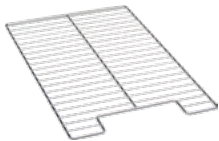

V-RACK61
Set of 3 stainless steel half
size grab-and-go racks
Fits CHEF-61

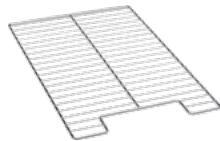

V-RACK101
Set of 5 stainless steel half
size grab-and-go racks
Fits CHEF-101



V-RACK62
Set of 3 stainless steel full
size grab-and-go racks
Fits CHEF-62



V-RACK102
Set of 5 stainless steel full
size grab-and-go racks
Fits CHEF-102

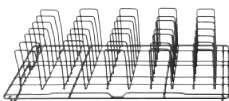

RIBRACK
Ribs rack
Fits all models



1220-GRILLOP
Grilling Grid (open type)
Fits all models

CHEF-GPAN1

Grease collection pan, quick
connect hose, and container
Fits CHEF-61, CHEF-101

CHEF-GPAN2

Fits CHEF-62, CHEF-102



CHEF'SCOMBI™ SERIES | *Field-Installed Accessories*



CHEF-STAND61
34.21" tall deluxe stand with pan supports



CHEF-STAND62
34.21" tall deluxe stand with pan supports



CHEF-STAND101
27.21" tall deluxe stand with pan supports



CHEF-STAND102
27.21" tall deluxe stand with pan supports



CHEF-DOOR61
Door kit for stands, includes left door + side
Fits CHEF-STAND61



CHEF-DOOR62
Door kit for stands, includes left door + side
Fits CHEF-STAND62



CHEF-DOOR101
Door kit for stands, includes left door + side
Fits CHEF-STAND101



CHEF-DOOR102
Door kit for stands, includes left door + side
Fits CHEF-STAND102



CHEF-CAST1
Stand caster kit (add 3.94" overall height)
Fits CHEF-STAND61, CHEF-STAND101



CHEF-CAST2
Stand caster kit (add 3.94" overall height)
Fits CHEF-STAND62, CHEF-STAND102



CHEF-ANTISLIP
Anti slip hygienic feet extension
Fits all models



CHEF-FLKIT
Floor anchoring kit for stands
Fits all models



CHEF-USBPROBE
USB core probe 3pts
Fits all models



CHEF-WIFI
Wifi dongle
Fits all models



CHEF-TAB
Cleaner Tabs (100 ct)
Fits all models



CHEF-STICK
Care Sticks (100ct)
Fits all models

CHEF-SVPROBE
USB "Sous vide" core probe
Fits all models

CHEF'SCOMBI™ SERIES | *Field-Installed Accessories*



CHEF-62 stacked on CHEF-102

Stacking combi ovens doubles cooking capacity without increasing kitchen footprint—ideal for space-limited environments.

STANDARD FEATURES:

- Chef'sCombi units are field stackable, allowing kitchens to expand or reconfigure easily as needs change, without costly renovations.
- Stacked ovens improve cooking speed, consistency, and reduce waste and labor.



**CHEF-STACK1E
CHEF-STACK1G**

Stacking kit for half size, electric or gas models
Fits CHEF-61,
CHEF-101

One of the following support frame choices is required with a stacking kit:



CHEF-6NLEG1
6" Support frame, hardware, and special lifting wood pallet
Fits CHEF-61, CHEF-101



CHEF-10NLEG1
10" Support frame, hardware, and special lifting wood pallet
Fits CHEF-61, CHEF-101
(for longer drain connections and 6/6 stacked units)



CHEF-6NCAST1
6" Mobile stand on casters, hardware, and special lifting wood pallet
Fits CHEF-61, CHEF-101



**CHEF-STACK2E
CHEF-STACK2G**

Stacking kit for full size, electric or gas models
Fits CHEF-62,
CHEF-102

One of the following support frame choices is required with a stacking kit:



CHEF-6NLEG2
6" Support frame, hardware, and special lifting wood pallet
Fits CHEF-62, CHEF-102



CHEF-10NLEG2
10" Support frame, hardware, and special lifting wood pallet
Fits CHEF-62, CHEF-102
(for longer drain connections and 6/6 stacked units)



CHEF-6NCAST2
6" Mobile stand on casters, hardware, and special lifting wood pallet
Fits CHEF-62, CHEF-102

CHEF'SCOMBI™ SERIES | *Field-Installed Accessories*

A vent hood helps remove steam, smoke, grease-laden vapors, and airborne pollutants, preventing them from lingering in the kitchen – affecting staff comfort or food quality.

STANDARD FEATURES:

- Efficiently removes steam, heat, and odors generated during cooking.
- Carbon or hepa filter options improve air quality.
- Removable filters and accessible components for quick cleaning.



CHEF-62E
shown with CHEF-HOOD2,
CHEF-HOODHEPA2 on
CHEF-STAND62



CHEF-HOOD1

Condensation hood
(for single or stacked oven
- *electric models only*)
Fits CHEF-61E, CHEF-101E

One or both of the following options can be used with CHEF-HOOD1:



CHEF-HOODCF1

Carbon filter option
(for fumes)
Fits CHEF-HOOD1



CHEF-HOODHEPA1

Hepa filter option
(for odors)
Fits CHEF-HOOD1



CHEF-HOOD2

Condensation hood
(for single or stacked oven
- *electric models only*)
Fits CHEF-62E, CHEF-102E

One or both of the following options can be used with CHEF-HOOD2:



CHEF-HOODCF2

Carbon filter option
(for fumes)
Fits CHEF-HOOD2



CHEF-HOODHEPA2

Hepa filter option
(for odors)
Fits CHEF-HOOD2



CHEF-HEAT61
CHEF-HEAT62
CHEF-HEAT101
CHEF-HEAT102
Heat shield for Chef'sCombi



CHEF-CVENTKIT

Direct vent kit
Fits all models



CHEF-DVENT1

Steam deflector
Fits CHEF-61, CHEF-101



CHEF-DVENT2

Steam deflector
Fits CHEF-62, CHEF-102

ABC SERIES | Multiple Cooking Capabilities from One Piece of Equipment

No programming and no training required. It's the combi you already know how to use.. as easy as ABC!

STANDARD FEATURES:

- Designed and assembled in the USA.
- Intuitive manual controls, just 3 knobs.
- Patented humidity level control automatically adjusts after setting temperature.
- Boilerless direct steam generation.
- Timer reloads for batch cooking after completion of timed cycle.
- Flashing door light and audible alarm system alert user when cooking cycle is finished.
- 4 stainless steel grab-and-go racks with 15½" x 3¼" cutout design for easy access to pans.
- Machine diagnostics through controls or via USB.
- Cool-to-the-touch and energy-efficient, heat-reflective tempered glass door.



ABC7G
Shown on optional ABC-STAND



ABC
Shown with optional stacking kit

ABC SERIES | ELECTRIC & GAS

Model Number	Input	Food Probe	Pan Capacity (with 7 wire racks)	
			18" x 26" Pans	12" x 20" Pans
GAS				
ABC7G-NAT	80,000 BTU/hr	No	7	14
ABC7G-PRO	80,000 BTU/hr	No	7	14
ELECTRIC				
ABC7E-208	18 kW	No	7	14
ABC7E-240	24 kW	No	7	14
ABC7E-480	24 kW	No	7	14

ABC-P SERIES | *Same as ABC Series, but with a Food Probe*

Cooking to a safe internal temperate is easier than ABC with included food probe.

STANDARD FEATURES:

- Designed and assembled in the USA.
- Intuitive manual controls, just 3 knobs.
- Patented humidity level control automatically adjusts after setting temperature.
- Boilerless direct steam generation.
- Timer reloads for batch cooking after completion of timed cycle.
- Flashing door light and audible alarm system alert user when cooking cycle is finished.
- 4 stainless steel grab-and-go racks with 15½" x 3¼" cutout design for easy access to pans.
- Machine diagnostics through controls or via USB.
- Cool-to-the-touch and energy-efficient, heat-reflective tempered glass door.
- Food probe to cook to an internal set temperature or to cook via time and check internal food temperature.
- Fan speed control with 3 different speeds.







ABC7G-NATP

ABC-P SERIES | ELECTRIC & GAS







Model Number	Input	Food Probe	Pan Capacity (with 7 wire racks)	
			18" x 26" Pans	12" x 20" Pans
GAS				
ABC7G-NATP	80,000 BTU/hr	Yes	7	14
ABC7G-PROP	80,000 BTU/hr	Yes	7	14
ELECTRIC				
ABC7E-208P	18 kW	Yes	7	14
ABC7E-240P	24 kW	Yes	7	14
ABC7E-480P	24 kW	Yes	7	14

ABC / ABC-P SERIES | *Field-Installed Accessories*

	DESCRIPTION	ITEM #	FOR
	<p>STACKING KITS</p> <p>Stacking kit for ABC7 on top of VC4, VC6, SG4 or SG6 Convection Oven; includes Spray-ABC kit and casters</p>	<p>STACK-ABC/CONV</p>	<p>All ABC models</p>
	<p>Gas stacking kit for (2) ABC7G Combis. Includes Spray-ABC kit, drip tray and vent kit</p> <p>Electric stacking kit for (2) ABC7E Combis. Includes Spray-ABC kit, drip tray and vent kit</p>	<p>STACK-ABC/G</p> <p>STACK-ABC/E</p>	<p>ABCG models</p> <p>ABCE models</p>
	<p>FEET</p> <p>Set of 6" legs to be used in lieu of stacking kit casters</p>	<p>ABC-FEET</p>	<p>Stacked ABC models</p>
	<p>STAND WITH CASTER OPTION</p> <p>Stainless steel stand, open-leg frame with base, adjustable feet. Includes Spray-ABC kit and drip tray</p>	<p>ABC-STAND</p>	<p>All ABC models</p>
	<p>Casters with 2 locking wheels for use with ABC-STAND</p>	<p>ABC-CAST</p>	<p>ABC-STAND</p>

BOILERLESS COMBI OVENS **VULCAN**

ABC / ABC-P SERIES | *Field-Installed Accessories*

	DESCRIPTION	ITEM #	FOR
	RACKS 1 stainless steel grab-and-go rack Set of 3 stainless steel grab-and-go racks	ADDRACK-ABC1 ADDRACK-ABC3	ABC models ABC models
		FRY BASKET Stainless steel fry basket 12" x 20"	1220-BASKET
	GRILLING GRID Grilling grid (open type)	1220-GRILLOP	All models
	HOSES Flex stainless steel water connection 72", 3/4 GHT on both ends, per each, 2 recommended	HOSEWTR 3/4BBV	All gas models
		3/4" x 4' quick disconnect hose with restraining device	3/4QD-HOSE-4
	SPRAY HOSE KIT Includes plumbing connections, spray hose and mounting bracket	V-SPRAY	All models

See page 140 for water softener & filtration options.

MINIJET™ SERIES | *Think Simple, Smart, Small.*

Get the speed, precision, and versatility of combi cooking - in a small and powerful package. The simplicity of the Minijet™ delivers consistent results for every level of user.



MINI-JETR
Shown on MINI-STAND



MINI-JET
Shown on legs

STANDARD FEATURES:

- Multiple cooking capabilities from one piece of equipment: bake, steam, roast, grill, air-fry, retherm, proof, finish, poach, stew, low temp, defrost, cook & hold, and more.
- Twin control with both capacitive LCD touchscreen and turn/push knob.
- PC software for transfer of recipes, photographs, and profiles via USB.
- Freedom to use Vulcan Combi Oven Detergent and Rinse Aid, or non-proprietary liquid detergents for more control to the operators.
- Exclusive ABC interface lets operators cook with confidence.

Multi-function interfaces for every user

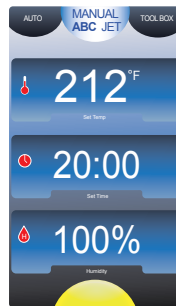

ABC interface auto sets optimal humidity with temperature selection (patented)



AUTO interface features preloaded and programmable recipes with picture or text display



CLEANING uses non-proprietary liquid detergent, also programmable as daily routine

MINIJET™ SERIES | ELECTRIC

Model	Description	Input	Pan Capacity	
			18" x 20"x 2.5" Pans	13" x 18" x 1" Pans
MINI-JET	Mini Combi – left hinged (includes legs, cord and plug)	208/240/60/1/3 5.2 / 6.83 kw	4	4
MINI-JETR	Mini Combi – right hinged (includes legs, cord and plug)	208/240/60/1/3 5.2 / 6.83 kw	4	4











All Minijet™ units ship 208V, 60Hz, 3 Phase with L15-30P cord and plug (field convertible).

The Minijet was tested for Ventless Grease Laden Vapor Approval by UL in accordance with EPA test method 202 resulting in grease-laden effluents collected at just 1.52 mg/m³, less than the 5.0 mg/m³ limit without the need for an additional system or listing. Certification for Commercial Cooking Appliances with Integral Systems for Limiting the Emission of Grease-laden Air (KNLZ) also apply to the Minijet or stacked Minijets using optional hood MINI-HOOD1 or MINI-HOOD2. Local codes prevail.

BOILERLESS COMBI OVENS

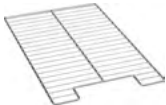

MINIJET™ SERIES | *Field-Installed Accessories*

	DESCRIPTION	ITEM #	FOR
	STACKING KITS Stacking kit for 2 Minijet units includes 13.75" stainless steel stand, adjustable feet, and floor flanges	MINI-STACK2	Minijet models
	Stacking kit for 1 or 2 Minijet units on top of VC4 Convection Oven; includes casters	STACK-MINI/CONV	Minijet models
	STAND Stainless steel stand with 2 shelves, adjustable feet and floor flanges	MINI-STAND	Minijet models
	HOOD Vapor condensing hood	MINI-HOOD1 MINI-HOOD2	Single Minijet models Double Minijet models
	SPRAY HOSE KIT Manual spray hose kit, includes plumbing connections, spray hose and mounting bracket for Minijet	V-SPRAY	Minijet models
	FOOD PROBE Multipoint food probe for Minijet	V-PROBE	Minijet models
	RACKS Set of 3 stainless steel grab-and-go racks 12" x 20"	MINI-RACK	Minijet models
	FRY BASKET Stainless steel fry basket 12" x 20"	1220-BASKET	All models
	GRILLING GRID Grilling grid (open type)	1220-GRILLOP	All models
	WATER CONNECTION HOSE Flex stainless steel water connection 72", 3/4 GHT on both ends, per each, 2 recommended	HOSEWTR 3/4BBV	All gas models
	CHEMICALS Vulcan liquid detergent, 2.5 gal each, 2 per pack Vulcan rinse aid (descale), 2.5 gal each, 2 per pack	VDL-1 VRL-1	Minijet models

FIELD-INSTALLED WATER TREATMENT OPTIONS**GOOD: MINIMUM FILTRATION** | For All Combi Ovens



Hollow Carbon Filter System with 15,000-Gallon Capacity

CB15K-SYSTEM *(All combi units)*

Hollow Carbon Filter System with 30,000-Gallon Capacity

CB30K-SYSTEM *(All combi units)*



Replacement cartridge - PM Kit

CB15K-PMKIT

(for CB15K-SYSTEM)

Replacement cartridge - PM Kit

CB30K-PMKIT

(for CB30K-SYSTEM)

BETTER: WATER SOFTENER + CARBON FILTER SYSTEM | For All Combi Ovens

Carbon Filter System is required with softener



Water Softening System, 4,818 grains / 80-lb capacity, with salt alarm

WS80-NOINSTALL

(All combi units)



Water Softening System, 2,527 grains / 40-lb capacity, with salt alarm

WS40-NOINSTALL

(All combi units)

FIELD-INSTALLED WATER TREATMENT OPTIONS

BEST: REVERSE OSMOSIS SYSTEM | For ABC and Minijet™



RO water filtration system—capable of 200 gpd (double combi)

V3MRO-2 (for all ABC & Minijet™ units)



Replacement cartridge - PM Kit

V3MRO-PMF

(for 1) V3MRO carbon filter)



Replacement cartridge - PM Kit

V3MRO-PMM

(for 1) V3MRO membrane filter)

BEST: SCALEBLOCKER® FILTRATION SYSTEM | For Chef'sCombi™



Filtration System includes housing, cartridge, o-rings, and water hardness test kit

SMF600 SYSTEM

(for Chef'sCombi™)



ScaleBlocker® Kit includes cartridge

SMF600 PMKIT

(for SFM600 SYSTEM)



Filtration System includes housing, cartridge, o-rings, and water hardness test kit

SMF620 SYSTEM

(for stacked Chef'sCombi™)



ScaleBlocker® Kit includes cartridge

SMF620 PMKIT

(for SFM620 SYSTEM)

Water is a customer-supplied utility to the equipment. Proper water filtration based on customer water quality is essential to meet the equipment water spec requirements. Verify the type of filtration needed based on performing a cold water analysis from the customer site. A suitable water treatment system and regular filter replacements coupled with routine cleaning/deliming are required. It is recommended to upgrade to ScaleBlocker, but not required if auto descale cycles are routinely performed.

FRYER LINE UP

Our innovative fryers are built for performance and profit. Easy to operate and maintain, they boost productivity while keeping operating costs low. With fast recovery times, they're designed to be among the most efficient and profitable pieces of equipment in any commercial kitchen.



	Gas Fryers - Series				Electric Fryers - Series	
	PowerFry™	GR	VEG	LG	ER	CEF
Configuration	Floor	Floor	Floor	Floor	Floor	Countertop
ENERGY STAR® certified		N/A		N/A		CEF40
Oil capacity (lbs) per tank	50, 70, 90	40, 50, 70, 90	35, 50	40, 50, 70	50, 85	40, 75
*Controls	A / D / C	M	M	M	A / D / C	A
Production output	High/Med	Med/low	High/Med	Med/low	High/Med	High/Med
Basket lifts ¹	C/D models	N/A	N/A	N/A	C/D models	N/A
Oil reclamation hook up ²	C/D models	GRMF models	N/A	N/A	C/D models	N/A
KleenScreen® PLUS Filtration system	"-F" models & 2, 3, and 4 battered	"-F" models & 2, 3, and 4 battered	N/A	N/A	"-F" models & 2, 3, and 4 battered	N/A

*Controls: A - Analog, D - Digital, C - Computer, M - Millivolt.

¹Basket lifts automatically lift baskets from oil when the timer has stopped. This allows operators to produce consistent product each time and minimizes waste due to user error.

²Oil reclamation systems allow restaurant operators to remove used oil easily and safely from their kitchens. Used cooking oil is transferred to a collection tank and then taken off site by a third-party company for refinement into clean biofuels.

FRYERS | How to Read Model Numbers for Gas and Electric Fryers

POWERFRY5™ (VK) / POWERFRY3™ (TR) / VEG / GR SERIES					
# of Fry Tanks	Model Number	Size of Tank (lbs)	Control Type	 KleenScreen® PLUS Filtration System	Gas Type
1	TR	45	D	F*	-1
Options (see specific product section for availability)					
1	GR	35 lbs	A = Solid State Analog (Knob)	*2-, 3- and 4-battery fryers come standard with KleenScreen® PLUS Filtration System	-1 = Natural Gas -2 = Propane Gas (LP)
2	TR	50 lbs	D = Solid State Digital		
3	VK	70 lbs	C = Programmable Computer		
4	VEG VHG	85 lbs	M = Millivolt (GR & VEG only)		

EXAMPLES:

1TR45DF-1 = PowerFry3™ Freestanding Gas 50 lb Solid State Digital Control Fryer with KleenScreen® PLUS Filtration, LP Gas

1VK45A-2 = PowerFry5™ Freestanding Gas 50 lb Solid State Analog (Knob) Control Fryer, LP Gas

1GR35M-1 = GR Series, Freestanding Gas 40 lb Millivolt Control Fryer, Natural Gas

1VEG35M-1 = Freestanding Gas 40 lb Millivolt Control Fryer, Natural Gas

2VK85CF-1 = PowerFry5™ 2-Battery Gas 90 lb Programmable Computer Control Fryer with KleenScreen® PLUS Filtration, Natural Gas

ER SERIES					
# of Fry Tanks	Model Number	Size of Tank (lbs)	Control type	 KleenScreen® PLUS Filtration System	Voltage/Hz/Phase
1	ER	50	C	F*	-1
1	ER	50 lbs	A = Solid State Analog (Knob)	*2-, 3- and 4-battery fryers come standard with KleenScreen® PLUS Filtration System	-1 = 208V, 50-60Hz, 3 Phase -2 = 480V, 50-60Hz, 3 Phase -3 = 240V, 50-60Hz, 3 Phase
2		85 lbs	C = Programmable Computer		
3			D = Solid State Digital		
4					

EXAMPLES:

1ER50D-1 = Freestanding Electric 50 lb Solid State Digital Control Fryer, 208V, 50-60Hz, 3 Phase

1ER50A-2 = Freestanding Electric 50 lb Solid State Analog (Knob) Control Fryer, 480V, 50-60Hz, 3 Phase

2ER85CF-2 = 2-Battery Electric 90 lb Programmable Computer Control Fryer, 480V, 50-60Hz, 3 Phase

POWERFRY™ SERIES GAS FRYERS | Control Options



Feature	Solid State Analog Knob (A)	Solid State Digital Controls (D)	Programmable Computer Controls (C)
Temperature Control	Knob (200°–400°F)	Digital (200°–390°F)	Digital (200°–390°F)
Recovery ¹	Fast — reacts within 1-2°F of set temperature		
Melt Modes	Liquid & Solid	Liquid, Solid & No Melt	Liquid, Solid & No Melt
Optional KleenScreen® PLUS Filtration System	✓	✓	✓
Boil-Out ²	N/A	Auto temp. controlled	Auto temp. controlled
Compensating time adjusts for load capacity	N/A	✓	✓
Basket lift ³ compatible	N/A	✓	✓
Countdown timer	N/A	2	N/A
Secondary Programming	N/A	N/A	Shake & Hold time
Screen	N/A	Digital display	Large digital display
Programmable menu items	N/A	N/A	10 w/product names

- ¹Recovery refers to the length of time it takes for the oil temperature to rise back to set temperature after frozen or cold food has been dropped in.
- ²Boil-Out is a popular method used to clean a commercial fryer by boiling water and cleaning solution in an empty frypot.
- ³Basket lifts automatically lift baskets from oil when the timer has stopped. This allows operators to produce consistent product each time and minimizes waste due to user error.



POWERFRY5™ (VK SERIES) | *Vulcan's Most Energy-Efficient Fryer*



1VK45DF

Solid State Digital controls (D)

STANDARD FEATURES

- Patented FivePass™ heat transfer system for maximum efficiency and shorter cooking time.
- Less than 500°F flue temperatures at maximum production rate.
- Boil Out ByPass™, which easily removes boil out solution from fry tank without contact of drain manifold, filter pan or motor/pump.
- SoftStart™ ignition system heats cold oil gently, extending oil life.
- Available with KleenScreen® PLUS Filtration System.
- Electronic ignition —power button starts the fryer instantly.
- C and D models available with basket lifts and rear oil reclamation
- Trouble-free adjustable casters; 2 swivel non-locking and 2 swivel locking.
- 10-year limited tank warranty.
- Larger drain manifold in units with built-in filtration, resulting in increased flow.
- ENERGY STAR® certified.

POWERFRY5™ (VK SERIES) | DIMENSIONS

Model	Controls	Dimensions (W x D x H)	Working Height	Tank Size
Freestanding Fryers 50 lb, 70 lb, and 90 lb				
1VK45	A / D / C	15½" x 30⅞" x 47⅞"	36¼"	14" x 14"
1VK45	AF / DF / CF	15½" x 30⅞" x 47⅞"	36¼"	14" x 14"
1VK65	A / D / C	21" x 30⅞" x 47⅞"	36¼"	19½" x 14"
1VK65	AF / DF / CF	21" x 30⅞" x 47⅞"	36¼"	19½" x 14"
1VK85	A / D / C	21" x 34⅜" x 47⅞"	36¼"	19½" x 18¼"
1VK85	AF / DF / CF	21" x 34⅜" x 47⅞"	36¼"	19½" x 18¼"
Battery: 2 Fryers 50 lb, 70 lb, and 90 lb				
2VK45	AF / DF / CF	31" x 30⅞" x 47⅞"	36¼"	14" x 14"
2VK65	AF / DF / CF	42" x 30⅞" x 47⅞"	36¼"	19½" x 14"
2VK85	AF / DF / CF	42" x 34⅜" x 47⅞"	36¼"	19½" x 18¼"
Battery: 3 Fryers 50 lb, 70 lb, and 90 lb				
3VK45	AF / DF / CF	46½" x 30⅞" x 47⅞"	36¼"	14" x 14"
3VK65	AF / DF / CF	63" x 30⅞" x 47⅞"	36¼"	19½" x 14"
3VK85	AF / DF / CF	63" x 34⅜" x 47⅞"	36¼"	19½" x 18¼"
Battery: 4 Fryers 50 lb, 70 lb, and 90 lb				
4VK45	AF / DF / CF	62" x 30⅞" x 47⅞"	36¼"	14" x 14"
4VK65	AF / DF / CF	84" x 30⅞" x 47⅞"	36¼"	19½" x 14"
4VK85	AF / DF / CF	84" x 34⅜" x 47⅞"	36¼"	19½" x 18¼"

- A = Solid State Analog (Knob) | D = Solid State Digital | C = Programmable Computer | F = KleenScreen® PLUS Filtration
- **For 50 lb, 70 lb and 90 lb Gas Fryers:**
2-, 3- and 4-battery fryers come standard with KleenScreen® PLUS Filtration Systems.
Models ending in "-1" indicate fryer uses natural gas. Models ending in "-2" indicate fryer uses propane gas (LP).



POWERFRY5™ (VK SERIES) | Vulcan's Most Energy-Efficient Fryer



1VK45A
Solid state Analog Controls (A)



1VK45D
Solid State Digital Controls (D)



1VK45C
Solid State Computer Controls (C)



1VK65D
Solid State Digital Controls (D)



2VK65CF
Solid State Computer Controls (C) with built-in KleenScreen® PLUS Filtration

POWERFRY5™ (VK SERIES) | CAPACITY & PRODUCTION

Model	Controls	Tanks	Total Oil Capacity	Production lbs/hr	Total BTU/hr	Built-in Filtration
50 lb PowerFry 5™ Gas Fryers						
1VK45	A / D / C	1	50 lbs	78.1 lbs	70,000	No
1VK45	AF / DF / CF	1	50 lbs	78.1 lbs	70,000	Yes
2VK45	AF / DF / CF	2	100 lbs	156.2 lbs	140,000	Yes
3VK45	AF / DF / CF	3	150 lbs	234.3 lbs	210,000	Yes
4VK45	AF / DF / CF	4	200 lbs	312.4 lbs	280,000	Yes
70 lb PowerFry 5™ Gas Fryers						
1VK65	A / D / C	1	70 lbs	91.1 lbs	80,000	No
1VK65	AF / DF / CF	1	70 lbs	91.1 lbs	80,000	Yes
2VK65	AF / DF / CF	2	140 lbs	182.2 lbs	160,000	Yes
3VK65	AF / DF / CF	3	210 lbs	273.3 lbs	240,000	Yes
4VK65	AF / DF / CF	4	280 lbs	365.6 lbs	320,000	Yes
90 lb PowerFry 5™ Gas Fryers						
1VK85	A / D / C	1	90 lbs	100 lbs	90,000	No
1VK85	AF / DF / CF	1	90 lbs	100 lbs	90,000	Yes
2VK85	AF / DF / CF	2	180 lbs	200 lbs	180,000	Yes
3VK85	AF / DF / CF	3	270 lbs	300 lbs	270,000	Yes
4VK85	AF / DF / CF	4	360 lbs	400 lbs	360,000	Yes

- A = Solid State Analog (Knob) | D = Solid State Digital | C = Programmable Computer | F = KleenScreen® PLUS Filtration
- Models ending in "-1" indicate fryer uses natural gas. Models ending in "-2" indicate fryer uses propane gas (LP).



POWERFRY3™ (TR SERIES) | High Performance, Low Operating Costs



1TR45D
Solid State Digital Controls (D)

STANDARD FEATURES

- Patented ThreePass™ Heat Exchanger providing high energy efficiency.
- Less than 550°F flue temperatures at maximum production rate.
- Boil Out ByPass™, which easily removes boil out solution from fry tank without contact of drain manifold, filter pan or motor/pump.
- SoftStart™ ignition system heats cold oil gently, extending oil life.
- Available with KleenScreen® PLUS Filtration System.
- Electronic ignition —power button starts the fryer instantly.
- C and D models available with basket lifts or rear oil reclamation.
- Trouble-free adjustable casters — 2 swivel non-locking and 2 swivel locking.
- Larger drain manifold in units with built-in filtration, resulting in increased flow.
- 10-year limited tank warranty.
- ENERGY STAR® certified.

POWERFRY 3™ (TR SERIES) | DIMENSIONS

Model	Controls	Dimensions (W x D x H)	Working Height	Tank Size
Freestanding Fryers 50 lb, 70 lb, and 90 lb				
1TR45	A / D / C	15½" x 30⅞" x 47⅞"	36¼"	14" x 14"
1TR45	AF / DF / CF	15½" x 30⅞" x 47⅞"	36¼"	14" x 14"
1TR65	A / D / C	21" x 30⅞" x 47⅞"	36¼"	19½" x 14"
1TR65	AF / DF / CF	21" x 30⅞" x 47⅞"	36¼"	19½" x 14"
1TR85	A / D / C	21" x 34⅜" x 47⅞"	36¼"	19½" x 18¼"
1TR85	AF / DF / CF	21" x 34⅜" x 47⅞"	36¼"	19½" x 18¼"
Battery: 2 Fryers 50 lb, 70 lb, and 90 lb				
2TR45	AF / DF / CF	31" x 30⅞" x 47⅞"	36¼"	14" x 14"
2TR65	AF / DF / CF	42" x 30⅞" x 47⅞"	36¼"	19½" x 14"
2TR85	AF / DF / CF	42" x 34⅜" x 47⅞"	36¼"	19½" x 18¼"
Battery: 3 Fryers 50 lb, 70 lb, and 90 lb				
3TR45	AF / DF / CF	46½" x 30⅞" x 47⅞"	36¼"	14" x 14"
3TR65	AF / DF / CF	63" x 30⅞" x 47⅞"	36¼"	19½" x 14"
3TR85	AF / DF / CF	63" x 34⅜" x 47⅞"	36¼"	19½" x 18¼"
Battery: 4 Fryers 50 lb, 70 lb, and 90 lb				
4TR45	AF / DF / CF	62" x 30⅞" x 47⅞"	36¼"	14" x 14"
4TR65	AF / DF / CF	84" x 30⅞" x 47⅞"	36¼"	19½" x 14"
4TR85	AF / DF / CF	84" x 34⅜" x 47⅞"	36¼"	19½" x 18¼"

- A = Solid State Analog (Knob) | D = Solid State Digital | C = Programmable Computer | F = KleenScreen® PLUS Filtration
- **For 50 lb, 70 lb and 90 lb Gas Fryers:**
2-, 3- and 4-battery fryers come standard with KleenScreen® PLUS Filtration Systems.
Models ending in "-1" indicate fryer uses natural gas. Models ending in "-2" indicate fryer uses propane gas (LP).



POWERFRY3™ (TR SERIES) | High Performance, Low Operating Costs



1TR45A
Solid State Analog
Controls (A)



1TR45D
Solid State Digital
Controls (D)



1TR45C
Solid State Computer
Controls (C)



1TR65D
Solid State Digital
Controls (D)









POWERFRY 3™ (TR SERIES) | CAPACITY & PRODUCTION

Model	Controls	Tanks	Total Oil Capacity	Production lbs/hr	Total BTU/hr	Built-in Filtration
50 lb PowerFry 3™ Gas Fryers						
1TR45	A / D / C	1	50 lbs	69 lbs	70,000	No
1TR45	AF / DF / CF	1	50 lbs	69 lbs	70,000	Yes
2TR45	AF / DF / CF	2	100 lbs	138 lbs	140,000	Yes
3TR45	AF / DF / CF	3	150 lbs	207 lbs	210,000	Yes
4TR45	AF / DF / CF	4	200 lbs	276 lbs	280,000	Yes
70 lb PowerFry 3™ Gas Fryers						
1TR65	A / D / C	1	70 lbs	81.8 lbs	80,000	No
1TR65	AF / DF / CF	1	70 lbs	81.8 lbs	80,000	Yes
2TR65	AF / DF / CF	2	140 lbs	163.6 lbs	160,000	Yes
3TR65	AF / DF / CF	3	210 lbs	243.9 lbs	240,000	Yes
4TR65	AF / DF / CF	4	280 lbs	327.2 lbs	320,000	Yes
90 lb PowerFry 3™ Gas Fryers						
1TR85	A / D / C	1	90 lbs	86.8 lbs	90,000	No
1TR85	AF / DF / CF	1	90 lbs	86.8 lbs	90,000	Yes
2TR85	AF / DF / CF	2	180 lbs	173.6 lbs	180,000	Yes
3TR85	AF / DF / CF	3	270 lbs	260.4 lbs	270,000	Yes
4TR85	AF / DF / CF	4	360 lbs	347.2 lbs	360,000	Yes

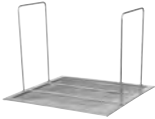
- A = Solid State Analog (Knob) | D = Solid State Digital | C = Programmable Computer | F = KleenScreen® PLUS Filtration
- Models ending in "-1" indicate fryer uses natural gas. Models ending in "-2" indicate fryer uses propane gas (LP).

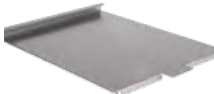

POWERFRY™ (TR & VK SERIES) | *Field-Installed Accessories*

	DESCRIPTION	ITEM #	FOR
	SINGLE BASKETS 13" x 13.25" x 6" 17.5" x 12.5" x 6" 18.5" x 15.5" x 6"	VBASKET-SINGLE BASKET-1TK65 VBASKET-SING85	50 lb PowerFryers 70 lb PowerFryers 90 lb PowerFryers
	TWIN BASKETS 6.25" x 12.75" x 6" 8.5" x 13.25" x 6" 9.25" x 17.5" x 6"	BASKETS-TWINRD BASKETS-TWIN65 VBASKET-TWIN85	50 lb PowerFryers 70 lb PowerFryers 90 lb PowerFryers
	TRI BASKETS 6.25" x 12.75" x 6"	BASKETS-TRI65	70 & 90 lb PowerFryers
	CRUMB SCREEN Crumb screen mesh with handles	CRUMB-SCREEN 65CRUMB-SCREEN 85CRUMB-SCREEN	50 lb PowerFryers 70 lb PowerFryers 90 lb PowerFryers
	SPLASH GUARD 10" High stainless steel removable splash guard	VSPGARD-G/E VSPGARD-ELE85	50 & 70 lb PowerFryers 90 lb PowerFryers
	TANK COVER Stainless steel tank cover / work surface top	COVER-TANK COVER-TANK65 COVER-TANK85	50 lb PowerFryers 70 lb PowerFryers 90 lb PowerFryers
	HOSE 4' gas flex hose & quick disconnect for freestanding fryers	3/4QD-HOSE-4 3/4" x 4' 11/4QDH-4FT 1-1/4" x 4'	All PowerFryers All PowerFryers
	CONNECTING KIT Secures 2 or more fryers together or with a Frymate™; includes grease strip and connecting hardware	CONNECT-KITVULPF CONNECT-KITVUL85PF	50 & 70 lb PowerFryers 90 lb PowerFryers
	MICRO-FILTRATION CONVERSION UPGRADE (KLEENSCREEN® PLUS) CONVERSION KIT Contains 3 fabric filter envelopes, stainless steel mesh insert and clip	CONVKIT-1 CONVKIT-2	Freestanding 50 lb Fryers All battery fryers
	REFILL KIT Contains 6 fabric filter envelopes	REFILLKIT-1 REFILLKIT-2	Freestanding 50 lb Fryers with filtration All battery fryers



POWERFRY™ | Factory-Installed Options

FACTORY-INSTALLED OPTIONS | VK & TR SERIES

Option Code	Description	For
SBL	Single basket lifts only available with (D) and (C) controls (adds 6 ¾" depth to unit)	70 lb & 90 lb PowerFry™ Fryers
DBL	Double basket lifts only available with (D) and (C) controls (adds 6 ¾" depth to unit)	50 lb, 70 lb & 90 lb PowerFry™ Fryers
OR	Patented rear oil reclamation hook-up with lockable gate valve (see below)	PowerFry™ freestanding and battery filtered units

- Basket lifts automatically lift baskets from oil when the timer has stopped. This allows operators to produce consistent product each time and minimizes waste due to user error.

Oil reclamation (OR) systems allow restaurant operators to remove used oil easily and safely from their kitchens. Used cooking oil is transferred to a collection tank and then taken off site by a third-party company for refinement into clean biofuels.

Vulcan's rear oil reclamation connection is compatible with most oil reclamation services.

Vulcan's patented Oil Reclamation Gate Valve allows for rear oil discarding. This locking mechanism directs the flow of oil to the rear of the fryer to the used holding tank.



Model Shown: 2VK45CF



POWERFRY™ (TR & VK SERIES) | Filtration Benefits

Longer oil life. Lower operating costs. Higher returns. Vulcan's KleenScreen® PLUS Filtration system all adds up to one thing—real savings for your kitchen.



STANDARD FEATURES

- Patented filtration system extends oil life 200–400%.
- An additional crumb screen basket acts as a pre-filter, capturing particulates to simplify cleaning and speed up filtration (PowerFry™ Fryer Battery only).
- High-temperature discard hose.
- Lightweight stainless steel pan (under 12 lbs.) for easy handling, simple cleaning, and dishwasher-safe convenience.
- Operates with most oil reclamation systems.
- Easy-to-use filter controls.
- Oil drain valve interlock switch with (A), (D), and (C) controls for each tank.
- Hands-free oil return line is self-seating when drawer is closed.



View demo video

The KleenScreen® PLUS Filtration system comes with a stainless steel mesh, but also has a fabric filter option:

Included: Stainless Steel mesh

Filters down to 60 microns (size of grain of salt).
Compatible with third-party paper filters

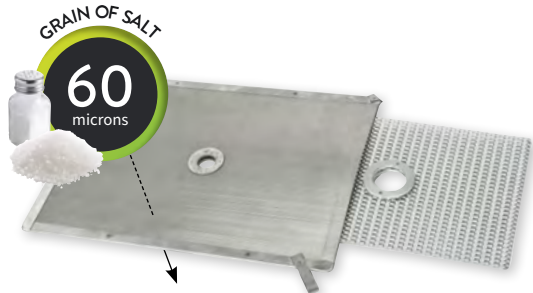

Upgrade: Fabric Filter

Filters down to .5 microns (size of red blood cell)

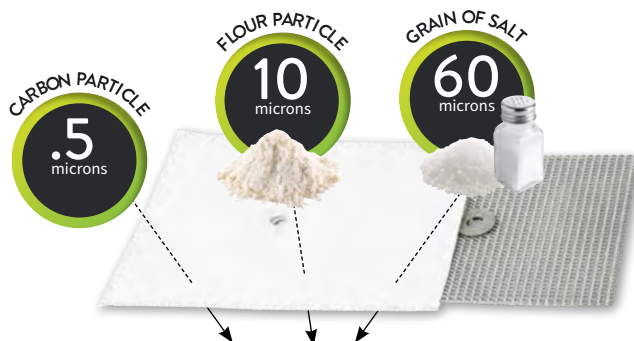

Micro-filtration conversion kit required.
See accessory page for more information.

Contact Vulcan Customer Service for additional options required when using solid shortening.



POWERFRY™ (TR & VK SERIES) | Filtration and Caster Locations

Screw Mount



Plate Mount



50 lb Vat Size

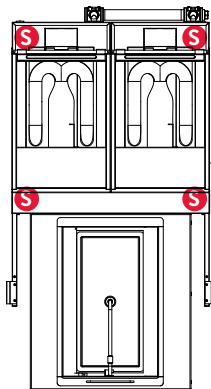

70 & 90 lb Vat Size

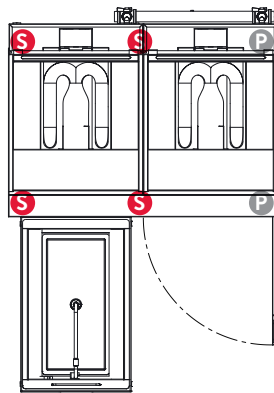

50 lb Vat Size

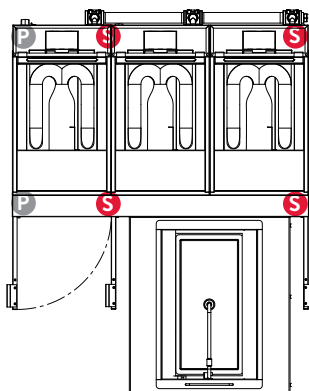

70 & 90 lb Vat Size

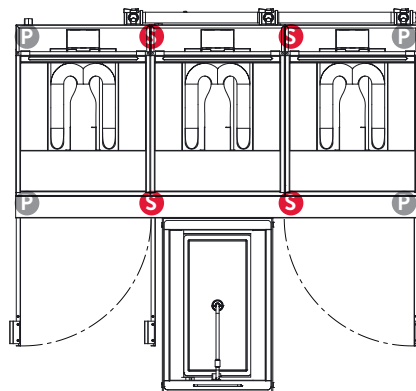

50 lb Vat Size

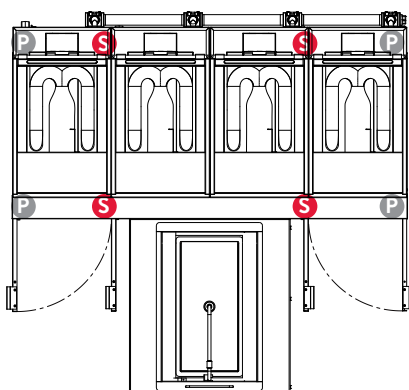

70 & 90 lb Vat Size

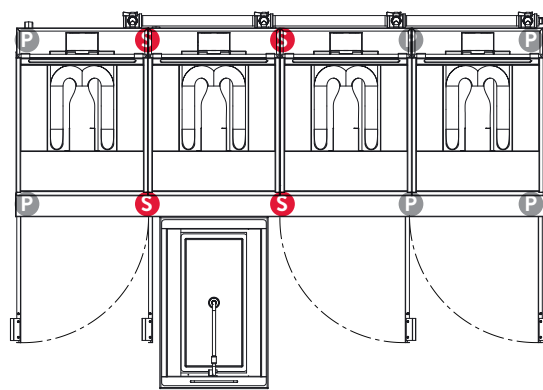

GR SERIES | Engineered for Effortless Operation and Maximum Time Savings



1GR45M*
Shown with VSPGARD-G/E

STANDARD FEATURES

- Designed to be versatile and used in nearly any location.
- No electrical hook-up required for M control fryers without filtration.
- Long-lasting, easy-to-clean stainless steel fry tank and cabinet.
- Tank brush, clean-out rod, and drain extension.
- Trouble-free adjustable casters—2 swivel non-locking and 2 swivel locking.
- GRMF models available with rear oil reclamation.
- 10-year limited tank warranty.

MILLIVOLT (M) CONTROL

- 200–400°F temperature range.
- Millivolt thermostat located behind door.
- Electric cord and plug not required (freestanding models).

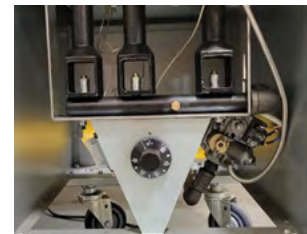

GR SERIES

Model	Dimensions (W x D x H)	Working Height	Number of Tanks	Tank Size	Total Oil Capacity	Total BTU/hr	Built-in Filtration
40 lb GR Fryers							
1GR35M	15½" x 30⅞" x 47⅞"	36¼"	1	14" x 14"	40 lbs	90,000	No
50 lb GR Fryers							
1GR45M	15½" x 30⅞" x 47⅞"	36¼"	1	14" x 14"	50 lbs	120,000	No
2GR45MF*	31" x 30⅞" x 47⅞"	36¼"	2	14" x 14"	100 lbs	240,000	Yes
3GR45MF*	46½" x 30⅞" x 47⅞"	36¼"	3	14" x 14"	150 lbs	360,000	Yes
4GR45MF*	62" x 30⅞" x 47⅞"	36¼"	4	14" x 14"	200 lbs	480,000	Yes
70 lb GR Fryers							
1GR65M	21" x 30⅞" x 47⅞"	36¼"	1	19½" x 14"	70 lbs	150,000	No
2GR65MF*	42" x 30⅞" x 47⅞"	36¼"	2	19½" x 14"	140 lbs	300,000	Yes
3GR65MF*	63" x 30⅞" x 47⅞"	36¼"	3	19½" x 14"	210 lbs	450,000	Yes
90 lb GR Fryers							
1GR85M	21" x 34⅜" x 47⅞"	36¼"	1	19½" x 18¼"	90 lbs	150,000	No
2GR85MF*	42" x 34⅜" x 47⅞"	36¼"	2	19½" x 18¼"	180 lbs	300,000	Yes
3GR85MF*	63" x 34⅜" x 47⅞"	36¼"	3	19½" x 18¼"	270 lbs	450,000	Yes







• For 50 lb, 70 lb and 90 lb Gas Fryers:

2-, 3- and 4-battery fryers come standard with KleenScreen® PLUS Filtration Systems.

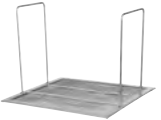
Models ending in "-1" indicate fryer uses natural gas. Models ending in "-2" indicate fryer uses propane gas (LP).

GRMF units require a power cord, to be supplied by customer; available with rear oil reclamation.

GR SERIES | Field-Installed Accessories

	DESCRIPTION	ITEM #	FOR
	SINGLE BASKETS 13" x 13.25" x 6" 17.5" x 12.5" x 6" 18.5" x 15.5" x 6"	VBASKET-SINGLE BASKET-1TK65 VBASKET-SING85	40 lb & 50 lb GR Fryers 70 lb GR Fryers 90 lb GR Fryers
	TWIN BASKETS 6.25" x 12.75" x 6" 8.5" x 13.25" x 6" 9.25" x 17.5" x 6"	BASKETS-TWINRD BASKETS-TWIN65 VBASKET-TWIN85	40 lb & 50 lb GR Fryers 70 lb GR Fryers 90 lb GR Fryers
	TRI BASKETS 6.25" x 12.75" x 6"	BASKETS-TRI65	70 lb & 90 lb GR Fryers
	CRUMB SCREEN Mesh crumb screen with handles	CRUMB-SCREEN 45CRUMB-SCREEN 65CRUMB-SCREEN 85CRUMB-SCREEN	40 lb GR Fryers 50 lb GR Fryers 70 lb GR Fryers 90 lb GR Fryers
	SPLASH GUARD 10" High stainless steel removable splash guard	VSPGARD-G/E VSPGARD-ELE85	40 lb, 50 lb & 70 lb GR Fryers 90 lb GR Fryers
	TANK COVER Stainless steel tank cover / work surface top	COVER-TANK COVER-TANK65 COVER-TANK85	40 lb & 50 lb GR Fryers 70 lb GR Fryers 90 lb GR Fryers
	HOSE 4' Gas flex hose & quick disconnect for freestanding fryers	3/4QD-HOSE-4 3/4" x 4' 11/4QDH-4FT 1-1/4" x 4'	all GR Fryers
	ADJUSTABLE LEGS 6" Adjustable legs (set of 4)	VULLEGS-PLTMNT	Single GR Fryers (not battered)
	CONNECTING KIT Secures 2 or more fryers together or with a Frymate™; includes grease strip and connecting hardware	CONNECT-KITVUL CONNECT-KITVUL85	40 lb, 50 lb & 70 lb GR Fryers 90 lb GR Fryers
	CONVERSION KIT Contains 3 fabric filter envelopes, stainless steel mesh insert and clip	CONVKIT-3 CONVKIT-2	40 lb & 50 lb GR Fryers 70 lb & 90 lb GR Fryers
	REFILL KIT Contains 6 fabric filter envelopes	REFILLKIT-3 REFILLKIT-2	40 lb & 50 lb GR Fryers 70 lb & 90 lb GR Fryers



GR SERIES | *KleenScreen® PLUS Filtration*

Longer oil life. Lower operating costs. Higher returns. Vulcan's KleenScreen® PLUS Filtration system all adds up to one thing—real savings for your kitchen.



2GR45MF

STANDARD FEATURES

- Patented filtration system extends oil life 200-400%.
- Operates with most oil reclamation systems.
- Hands-free oil return line is self-seating when drawer is closed.
- High-temperature discard hose.
- Easy-to-use filter controls.
- Lightweight stainless steel pan (under 12 lbs.) for easy handling, simple cleaning, and dishwasher-safe convenience.



View demo video

The KleenScreen® PLUS Filtration system comes with a stainless steel mesh, but also has a fabric filter option:

Included: Stainless Steel mesh

Filters down to 60 microns (size of grain of salt).
Compatible with third-party paper filters

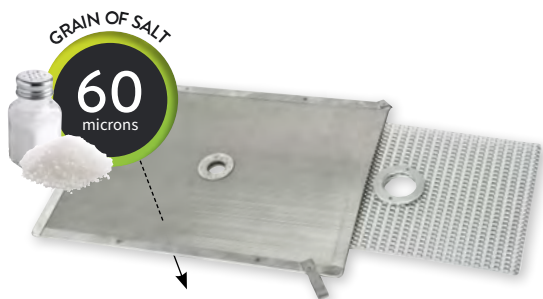

Please contact Vulcan Customer Service for additional options required when using solid shortening.

Upgrade: Fabric Filter

Filters down to .5 microns (size of red blood cell)

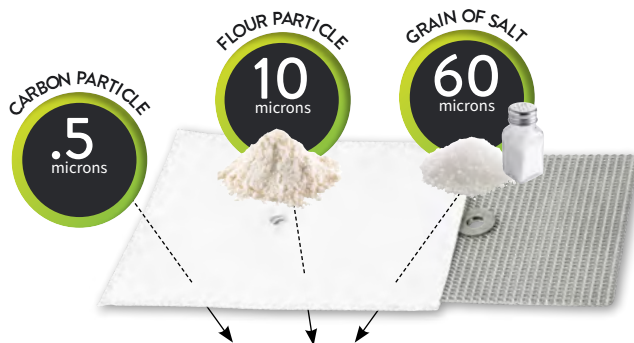

Micro-filtration conversion kit required.
See accessory page for more information.



GR SERIES | Filtration and Caster Locations

Screw Mount



Plate Mount



50 lb Vat Size

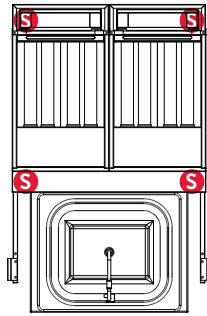

70 & 90 lb Vat Size

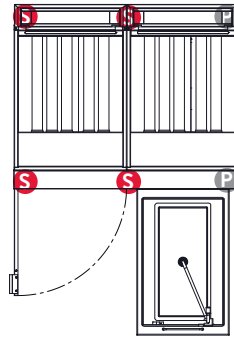

50 lb Vat Size

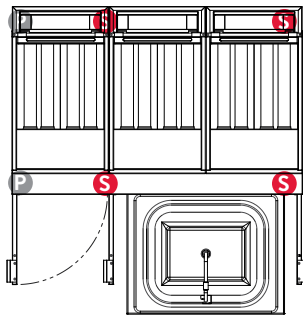

70 & 90 lb Vat Size

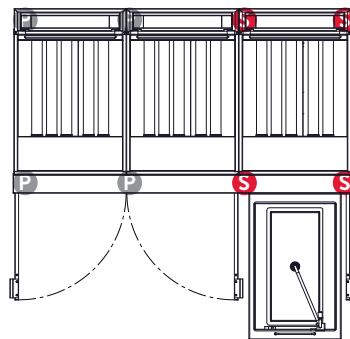

50 lb Vat Size

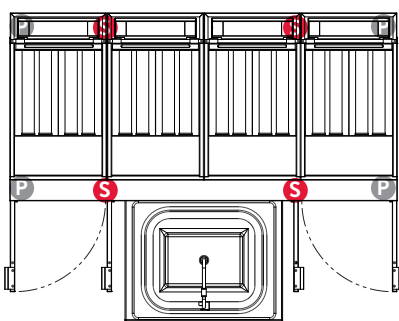

70 & 90 lb Vat Size

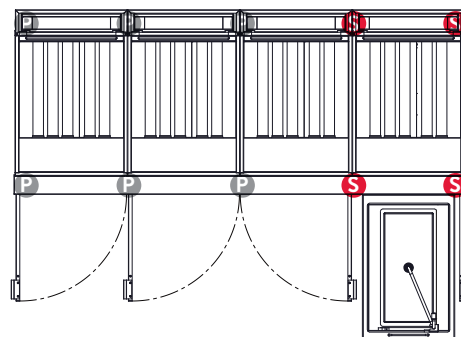



VEG SERIES | Value Priced — ENERGY STAR® Certified



1VEG35M
shown with accessory casters
(CASTERS-PLTMNT)

STANDARD FEATURES

- Efficient fryer that uses less gas without sacrificing production rate when compared to a standard economy fryer.
- Long-lasting, easy-to-clean stainless steel fry tank and front.
- Designed to be versatile and used in nearly any location — no electrical hook-up required.
- Drain extension and holder.
- Adjustable legs.
- 5-year limited tank warranty.
- ENERGY STAR® certified.

MILLIVOLT (M) CONTROL

- 200–400°F temperature range.
- Millivolt thermostat located behind door.
- Electric cord and plug not required (freestanding models).



VEG SERIES

Model	Dimensions (W x D x H)	Working Height	# of Tanks	Tank Size	Total Oil Capacity	Production lbs/hr	Total BTU/hr	Built-in Filtration
35 lb VEG Fryer								
1VEG35M-1	15½" x 29¾" x 46⅝"	34 ⅝"	1	14" x 14"	35 lbs	56.8 lbs	70,000	No
50 lb VEG Fryer								
1VEG50M-1	15½" x 29¾" x 46⅝"	34 ⅝"	1	14" x 14"	50 lbs	64.7 lbs	85,000	No

Propane not available.

LG SERIES | Dependable and Functional



LG300
shown with accessory casters
(CASTERS-PLTMNT)

STANDARD FEATURES

- Long-lasting, easy-to-clean stainless steel fry tank and front.
- Large cold zone area extends oil life.
- Designed to be versatile and used in nearly any location — no electrical hook-up required.
- High-limit shut-off protector shuts off gas combination valve and standing pilot if oil temperature gets too high.
- Drain extension and holder.
- Adjustable legs.
- 5-year limited tank warranty.

MILLIVOLT (M) CONTROL

- 200–400°F temperature range.
- Millivolt thermostat located behind door.
- Electric cord and plug not required (freestanding models).



LG SERIES

Model	Dimensions (W x D x H)	Working Height	Number of Tanks	Tank Size	Total Oil Capacity	Total BTU/hr	Built-in Filtration
40 lb LG Fryer							
LG300	15½" x 29¾" x 46⅝"	34 ⅝"	1	14" x 14"	40 lbs	90,000	No
50 lb LG Fryer							
LG400	15½" x 29¾" x 46⅝"	34 ⅝"	1	14" x 14"	50 lbs	120,000	No
70 lb LG Fryer							
LG500	21" x 29¾" x 46⅝"	34 ⅝"	1	19½" x 14"	70 lbs	150,000	No

• Models ending in "-1" indicate fryer uses natural gas. Models ending in "-2" indicate fryer uses propane gas (LP).

VEG & LG SERIES | *Field-Installed Accessories*

	DESCRIPTION	ITEM #	FOR
	SINGLE BASKETS 13" x 13.25" x 6" 17.5" x 12.5" x 6"	VBASKET-SINGLE BASKET-1TK65	VEG35 & LG300 Fryers LG500 Fryers
	TWIN BASKETS 6.25" x 12.75" x 6" 8.5" x 13.25" x 6"	BASKETS-TWINRD BASKETS-TWIN65	VEG35 & LG300 Fryers LG500 Fryers
	TRI BASKETS 6.25" x 12.75" x 6"	BASKETS-TRI65	LG500 Fryers
	CRUMB SCREEN Mesh crumb screen with handles	CRUMB-SCREEN 45CRUMB-SCREEN 65CRUMB-SCREEN	VEG35 & LG300 Fryers LG400 Fryers LG500 Fryers
	SPLASH GUARD 10" High stainless steel removable splash guard	VSPGUARD-G/E	All VEG / LG Fryers
	TANK COVER Stainless steel tank cover / work surface top	COVER-TANK COVER-TANK65	VEG35 & LG300 Fryers LG500 Fryers
	HOSE 4' gas flex hose & quick disconnect for freestanding fryers	3/4QD-HOSE-4 3/4" x 4' 11/4QDH-4FT 1-1/4" x 4'	All VEG / LG Fryers All VEG / LG Fryers
	CONNECTING KIT Secures 2 or more fryers together or with a Frymate™; includes grease strip and connecting hardware	CONNECT-KITVULPF CONNECT-KITVUL	All VEG Fryers All LG Fryers
	CASTERS Adjustable casters, 2 swivel non-locking & 2 swivel locking	CASTERS-PLTMNT	All VEG / LG Fryers

ER SERIES | Control Options



Feature	Solid State Analog Knob (A)	Solid State Digital Controls (D)	Programmable Computer Controls (C):
Temperature Control	Knob (200°–400°F)	Digital (200°–390°F)	Digital (200°–390°F)
Recovery ¹	Fast — reacts within 2°F of set temperature		
Melt Modes	Liquid & Solid	Liquid, Solid & No Melt	Liquid, Solid & No Melt
KleenScreen® PLUS Filtration System	✓	✓	✓
Boil-Out ²	N/A	Auto temp. controlled	Auto temp. controlled
Compensating time adjusts for load capacity	N/A	✓	✓
Basket lift ³ compatible	N/A	✓	✓
Countdown timer	N/A	2	N/A
Secondary Programming	N/A	N/A	Shake & Hold time
Screen	N/A	Digital display	Large digital display
Programmable menu items	N/A	N/A	10 w/product names

- ¹Recovery refers to the length of time it takes for the oil temperature to rise back to set temperature after frozen or cold food has been dropped in.
- ²Boil-Out is a popular method used to clean a commercial fryer by boiling water and cleaning solution in an empty frypot.
- ³Basket lifts automatically lift baskets from oil when the timer has stopped. This allows operators to produce consistent product each time and minimizes waste due to user error.



ER SERIES | *Energy Efficient and Highly Productive*



1ER85C
Shown with casters
(Casters-Pltmnt)

STANDARD FEATURES

- Ribbon style heating elements maximize surface area, recover quickly, and tilt up for easy cleaning.
- Long-lasting, easy-to-clean stainless steel front and cabinet.
- Adjustable legs.
- 17 kW elements on 50 lb models and 24 kW elements on 85 lb models.
- Tank brush, clean-out rod, and drain extension.
- C and D models available with basket lifts or rear oil reclamation.
- 10-year limited tank warranty.
- ENERGY STAR® certified.

ER SERIES | DIMENSIONS

Model	Controls	Dimensions (W x D x H)	Working Height	Tank Size
Freestanding ER Fryers 50 lb and 85 lb				
1ER50	A / D / C	15½" x 34¾" x 39⅞"	35¾"	14⅞" x 15½"
1ER50	AF / DF / CF	15½" x 34¾" x 39⅞"	35¾"	14⅞" x 15½"
1ER85	A / D / C	21" x 34¾" x 39⅞"	35¾"	19½" x 18"
1ER85	AF / DF / CF	21" x 34¾" x 39⅞"	35¾"	19½" x 18"
Battery: 2 ER Fryers 50 lb and 85 lb				
2ER50	AF / DF / CF	31" x 34¾" x 39⅞"	35¾"	14⅞" x 15½"
2ER85	AF / DF / CF	42" x 34¾" x 39⅞"	35¾"	19½" x 18"
Battery: 3 ER Fryers 50 lb and 85 lb				
3ER50	AF / DF / CF	46½" x 34¾" x 39⅞"	35¾"	14⅞" x 15½"
3ER85	AF / DF / CF	63" x 34¾" x 39⅞"	35¾"	19½" x 18"
Battery: 4 ER Fryers 50 lb				
4ER50	AF / DF / CF	62" x 34¾" x 39⅞"	35¾"	14⅞" x 15½"

- A = Solid State Analog (Knob) | D = Solid State Digital | C = Programmable Computer | F = KleenScreen® PLUS Filtration
- 2-, 3- and 4-battery fryers come standard with KleenScreen® PLUS Filtration System. Contact factory for 4ER85 Fryers.



ER SERIES | Energy Efficient and Highly Productive



1ER50AF
Solid State Knob
(A) Controls



1ER50D
Solid State Digital
(D) Controls



1ER50C
Programmable Computer
(C) Controls







1ER85D
Programmable Computer
(C) Controls

ER SERIES | CAPACITY & PRODUCTION

Model	Controls	Tanks	Total Oil Capacity	Production lbs/hr	kW	Built-in Filtration
50 lb ER Electric Fryers						
1ER50	A / D / C	1	50 lbs	57.7 lbs	17	No
1ER50	AF / DF / CF	1	50 lbs	57.7 lbs	17	Yes
2ER50	AF / DF / CF	2	100 lbs	115.4 lbs	34	Yes
3ER50	AF / DF / CF	3	150 lbs	173.10 lbs	51	Yes
4ER50	AF / DF / CF	4	200 lbs	230.8 lbs	68	Yes
85 lb ER Electric Fryers						
1ER85	A / D / C	1	85 lbs	81.8 lbs	24	No
1ER85	AF / DF / CF	1	85 lbs	81.8 lbs	24	Yes
2ER85	AF / DF / CF	2	170 lbs	163.6 lbs	48	Yes
3ER85	AF / DF / CF	3	255 lbs	243.9 lbs	72	Yes



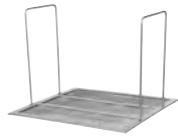

- A = Solid State Analog (Knob) | D = Solid State Digital | C = Programmable Computer | F = KleenScreen® PLUS Filtration
- Models ending in "-1" indicate 208V, 50-60 Hz, 3 Phase.
- Models ending in "-2" indicate 480V, 50-60 Hz, 3 Phase.
- Models ending in "-3" indicate 240V, 50-60 Hz, 3 Phase.
- Not available in 1 Phase.

ER SERIES | *Field-Installed Accessories*

	DESCRIPTION	ITEM #	FOR
	SINGLE BASKETS		
	13" x 13.25" x 6" 18.5" x 15.5" x 6"	VBASKET-SINGLE VBASKET-SING85	50 lb ER Fryers 85 lb ER Fryers
	TWIN BASKETS		
	6.25" x 12.75" x 6" 9.25" x 17.5" x 6"	BASKETS-TWINRD VBASKET-TWIN85	50 lb ER Fryers 85 lb ER Fryers
	TRI BASKETS		
	6.25" x 12.75" x 6"	BASKETS-TRI65	85 lb ER Fryers
	CRUMB SCREEN		
	Mesh crumb screen with handles	45CRUMB-SCREEN ER85CRUMB-SCREEN	50 lb ER Fryers 85 lb ER Fryers
	SPLASH GUARD		
	10" High stainless steel removable splash guard	VSPGARD-G/E VSPGARD-ELE85	50 lb ER Fryers 85 lb ER Fryers
	TANK COVER		
	Stainless steel tank cover / work surface top	COVER-TANK50 COVER-TNKE85	50 lb ER Fryers 85 lb ER Fryers

Continued on next page.

ER SERIES | *Field-Installed Accessories and Factory-Installed Options*

	DESCRIPTION	ITEM #	FOR
	CASTERS Trouble-free adjustable casters; 2 swivel non-locking & 2 swivel locking	CASTERS-PLTMNT Plate-mount	All ER Fryers
		CASTERS-VULSCR Screw-mount	All ER Fryers
			
	CONNECTING KIT Secures 2 or more fryers together or with a Frymate™; includes grease strip and connecting hardware	CONNECT-KITVUL	50 lb ER Fryers
		CONNECT-KITVUL85ELE	Second ER85 Fryer
		CONNECT-KITVUL85ELEVX	Frymate™ VX21S
	MICRO-FILTRATION CONVERSION UPGRADE (KLEENSCREEN® PLUS) CONVERSION KIT Contains 3 fabric filter envelopes, stainless steel mesh insert and clip	CONVKIT-1	50 lb ER Fryers
		CONVKIT-2	85 lb ER Fryers
	REFILL KIT Contains 6 fabric filter envelopes	REFILLKIT-1	50 lb ER Fryers
		REFILLKIT-2	85 lb ER Fryers

FACTORY-INSTALLED OPTION



DESCRIPTION	ITEM #	FOR
RECLAMATION HOOK UP Patented rear oil reclamation hook-up with lockable gate valve See page 150 for more detail	OR	50 lb & 85 lb ER freestanding and battery filtered units
BASKET LIFT Single basket lifts available only with (D) and (C) controls (adds 6 3/4" depth to unit)	SBL	50 lb & 85 lb ER Fryers

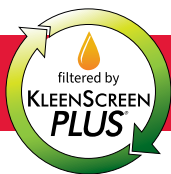

ER SERIES | *KleenScreen® PLUS Filtration*

Longer oil life. Lower operating costs. Higher returns. Vulcan's KleenScreen® PLUS Filtration system all adds up to one thing—real savings for your kitchen.



STANDARD FEATURES

- Patented filtration system extends oil life 200–400%.
- Operates with most oil reclamation systems.
- High-temperature discard hose.
- Lightweight stainless steel pan (under 12 lbs.) for easy handling, simple cleaning, and dishwasher-safe convenience.
- Easy-to-use filter controls.
- Oil drain valve interlock switch with (A), (D) and (C) controls for each tank.
- Hands-free oil return line is self-seating when drawer is closed.



View demo video

The KleenScreen® PLUS Filtration system comes with a stainless steel mesh, but also has a fabric filter option:

Included: Stainless Steel mesh

Filters down to 60 microns (size of grain of salt).
Compatible with third-party paper filters

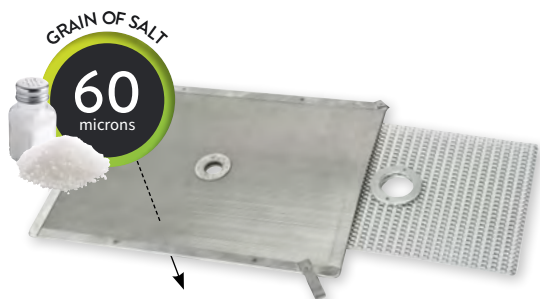

Upgrade: Fabric Filter

Filters down to .5 microns (size of red blood cell)

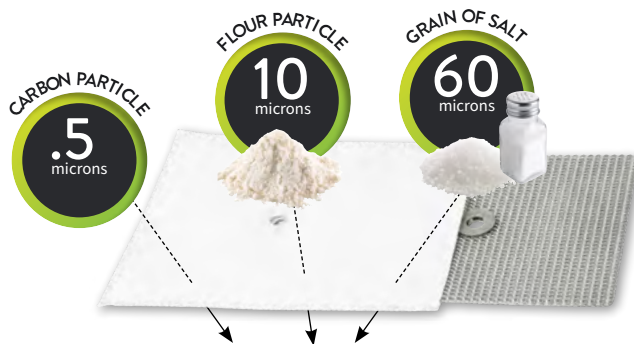

Micro-filtration conversion kit required.
See accessory page for more information.

Please contact Vulcan Customer Service for additional options required when using solid shortening.



ER SERIES | Filtration and Caster Locations

Screw Mount



Plate Mount



50 and 85 lb Vat Size

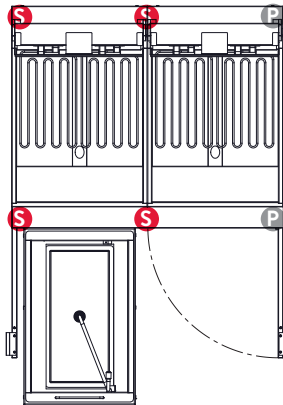

50 and 85 lb Vat Size

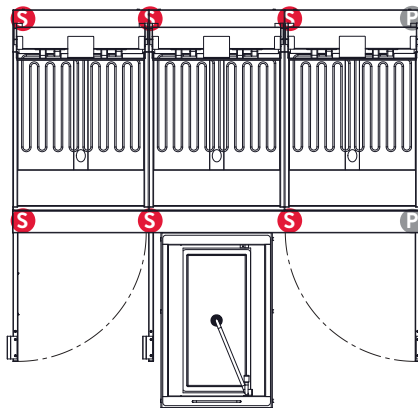

50 and 85 lb Vat Size

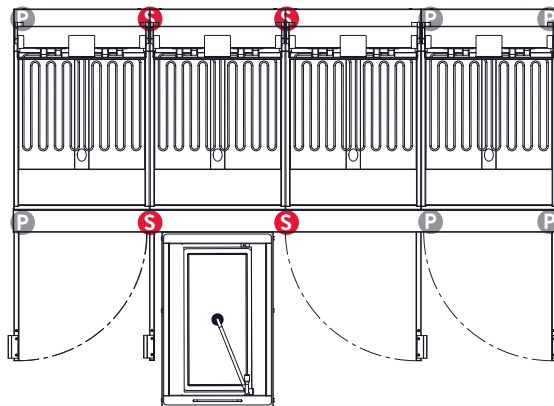

FRYMATE™ | *Keep Fried Food Warm and Ready To Serve*

The Frymate™ is a convenient fry holding station for both gas and electric fryers — either as an "add-on" or stand-alone model. Keep product warm with this easy-to-use fry station.



STANDARD FEATURES

- Stainless steel cabinet.
- Stainless steel curved pan to allow for easy removal of food products.
- Trouble-free adjustable casters — 2 swivel non-locking and 2 swivel locking.
- Storage area behind door.
- Can be installed on the left, right, or both sides of the fryer.

FRYMATE™ DUMP STATION

Model	Available Field Installed	Dimensions (W x D x H)
FRYMATE VX15	All 35-, 45-, 50- and 70 lb gas or electric fryers	15½" x 30⅝" x 36¼"
FRYMATE VX21S	All 85 lb gas or electric fryers	21" x 34⅜" x 36¼"

Each VX15 is shipped with a CONNECTKIT-VUL in the packaging and each VX21S is shipped with a CONNECTKIT-VUL85.

FIELD-INSTALLED ACCESSORIES

FRYER TANK COVER

Stainless steel tank cover / work surface top

COVER-TANK
for Frymate™ VX15

COVER-TANK85
for Frymate™ VX21S



FOOD WARMER

Infrared Food Warmer 120V (infrared food warming technology radiates uniform heat across surface)

FOOD-WARMER
For all Frymate™ Models



FRYMATE™ SERIES | *Field-Installed Connecting Kits*

Kits used for securing fryer to Frymate™. Includes grease strip and connecting hardware.

MODEL	CONNECTS TO	ITEM #
FOR 35 LB, 45 LB, 50 LB & 70 LB FRYERS:		
Frymate™ VX15	1VEG35M	CONNECT-KITVUL
	ER Freestanding Fryers - all 50 lb	CONNECT-KITVUL
	LG Freestanding Fryers - all 35-, 45- & 70 lb	CONNECT-KITVUL
	GR Freestanding Fryers - all 35-, 45- & 70 lb	CONNECT-KITVUL
	PowerFry5™ (VK) Freestanding Fryers - all 50- & 70 lb	CONNECT-KITVULPF
	PowerFry3™ (TR) Freestanding Fryers - all 50- & 70 lb	CONNECT-KITVULPF
FOR 85 LB & 90 LB FRYERS:		
Frymate™ VX21S	ER Freestanding Fryers - all 85 lb	CONNECT-KITVUL85ELEVX
	GR Freestanding Fryers - all 90 lb	CONNECT-KITVUL85
	PowerFry5™ (VK) Freestanding Fryers - all 90 lb	CONNECT-KITVUL85PF
	PowerFry3™ (TR) Freestanding Fryers - all 90 lb	CONNECT-KITVUL85PF

Each VX15 is shipped with a CONNECTKIT-VUL in the packaging and each VX21S is shipped with a CONNECTKIT-VUL85.

PORTABLE FILTRATION

Designed for versatility, Vulcan's Mobile Filter offers easy and efficient oil filtration for use with Vulcan Fryers or any brand of freestanding fryer.

STANDARD FEATURES

- Reusable stainless steel mesh filter screen assembly.
- 1/3 HP motor/pump, 8-gallon/min circulating hot oil.
- 6" wheels for ease of mobility with stainless steel handle.
- 300 Series, 16-gauge stainless steel filter vessel.
- 4' high-temperature oil discard hose.
- High oil capacity: holds up to 110 lbs. of oil.
- Removable large primary crumb catch basket.
- Filter pan removable for cleaning.
- Requires 14-gauge 5-15P plug extension cord (not supplied).



MF SERIES

Model	Description	Dimensions (W x D x H)
MF-1	120V, 60 Hz, 1 Phase	20" x 39 3/8" x 20 1/4"



FIELD-INSTALLED ACCESSORIES

MICRO-FILTRATION CONVERSION

Contains 3 fabric filter envelopes, stainless steel mesh insert and clip

CONVKIT-3
For MF-1



Micro-filtration filter envelopes refill (6-pack)

REFILLKIT-3
For MF-1



VPT PASS THROUGH (INSULATED) | *Most Durable Pass Through Available*



VPT13ES

Designed to keep food hot, fresh, and ready to serve, our Holding Cabinets deliver performance you can count on. With an energy-efficient design for faster preheating and recovery, plus durable construction built to last, they're a reliable addition to any kitchen operation.

STANDARD FEATURES:

- All components are 100% stainless steel.
- Digital controls.
- Dutch doors front and back (all VPT15 and VPT18 models).
- Welded frame.
- Accepts 18" x 26" (sheet pans) or 12" x 20" (hotel pans).
- Cabinet provides excellent heat distribution and recovery times.
- (4) 5" casters—2 swivel with locks and 2 rigid.

VPT SERIES

Model	Dimensions (W x D x H)	Sheet Pan Capacity	Hotel Pan Capacity	Adjustable Tray Slides	Volts	Watts	Amps
VPT7ES ¹	27¼" x 36½" x 40"	7	14	5	120	1,500	12.5
VPT13ES ¹	27¼" x 36½" x 59¾"	13	26	10	120	1,500	12.5
VPT15ES ¹	27¼" x 36½" x 65¼"	15	30	10	120	1,500	12.5
VPT18ES ¹	27¼" x 36½" x 69½"	18	36	15	120	1,500	12.5
VPT7SL ²	27¼" x 36½" x 40"	7	14	5	120	1,500	12.5
VPT15SL ²	27¼" x 36½" x 65¼"	15	30	10	120	1,500	12.5
VPT7LL ³	27¼" x 36½" x 40"	15	N/A	5	120	1,500	12.5
VPT15LL ³	27¼" x 36½" x 65¼"	30	N/A	10	120	1,500	12.5

Sheet pan = 18" x 26" | Hotel pan = 12" x 20"

¹Base models include fully adjustable tray slides.

²SL models include adjustable shelves.

³LL models include fixed lipload racking.



VBP INSTITUTIONAL SERIES (INSULATED)

Holding Cabinets that are ideal for schools, restaurants, and hospitals.

STANDARD FEATURES:

- All components are 100% stainless steel.
- Digital controls.
- Dutch doors (all VBP15ES and VBP18ES models).
- Field-reversible doors.
- Welded frame.
- Accepts 18" x 26" (sheet pans) or 12" x 20" (hotel pans).
- Cabinet provides excellent heat distribution and recovery times.
- (4) 5" casters—2 swivel with locks and 2 rigid (3" casters with VBP5ES).
- ENERGY STAR® certified.



VBP13ES



VBP7SL

*with optional glass door
(glass door units are not
ENERGY STAR® certified)*



VBP18ES

with optional bumper

VBP SERIES

Model	Dimensions (W x D x H)	Sheet Pan Capacity	Hotel Pan Capacity	Adjustable Tray Slides	Volts	Watts	Amps
*VBP5ES ¹	27¼" x 33¼" x 30½"	5	10	5	120	1,500	12.5
VBP7ES ¹	27¼" x 33¼" x 40¼"	7	14	5	120	1,500	12.5
VBP13ES ¹	27¼" x 33¼" x 59¾"	13	26	10	120	1,500	12.5
VBP15ES ¹	27¼" x 33¼" x 65½"	15	30	10	120	1,500	12.5
VBP18ES ¹	27¼" x 33¼" x 69½"	18	36	15	120	1,500	12.5
VBP7SL ²	27¼" x 33¼" x 40¼"	7	14	5	120	1,500	12.5
VBP15SL ²	27¼" x 33¼" x 65½"	15	30	10	120	1,500	12.5
VBP7LL ³	27¼" x 33¼" x 40¼"	15	N/A	5	120	1,500	12.5
VBP15LL ³	27¼" x 33¼" x 65¼"	30	N/A	10	120	1,500	12.5

Sheet pan = 18" x 26" | Hotel pan = 12" x 20"

**VBP5ES ships with 3" casters*

¹Base models include fully adjustable tray slides.

²SL models include adjustable shelves. VBP7SL includes 3 shelves; VBP15SL includes 6 shelves.

³LL models include fixed lipload racking.

VHP SLIM-LINE (INSULATED) HOTEL PAN SERIES

Holding Cabinets for those tight spaces.

STANDARD FEATURES:

- Field-reversible doors.
- All components are 100% stainless steel.
- Fixed tray slides.
- Accepts 12" x 20" hotel steam pans.
- Cabinet provides excellent heat distribution and recovery times.
- (4) 5" casters—2 swivel with locks and 2 rigid.





VBP SERIES

Model	Dimensions (W x D x H)	Hotel Pan Capacity	Volts	Watts	Amps
VHP7	17¼" x 27½" x 36¾"	7	120	1,500	12.5
VHP15	17¼" x 27½" x 60½"	15	120	1,500	12.5

Hotel pan = 12" x 20"

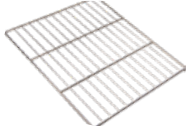
VPT, VBP & VHP SERIES | *Field-Installed Accessories & Factory-Installed Options*

	DESCRIPTION	ITEM #	FOR
	STACKING KIT Stacking kit	STACKIT-VBP-CH	VPT & VBP models
	HUMIDITY PAN Humidity pan	PAN-HMD	VPT, VBP & VHP models
	WIRE RACK Wire pan grid with feet	RACK-VCH	VPT & VBP models with adjustable tray slides
	WIRE SHELF Wire shelf	SHELF-VRH8	VBPSL & VPTSL models
	TRAY SLIDE Universal tray slide pair	VI/PAN-SLIDES	VPT, VBP & VHP models
	3" CASTERS 3" Caster kit, 2 swivel with locks and 2 rigid	CASTERS-3INRR4	All models
	5" CASTERS 5" Caster kit, 2 swivel with locks and 2 rigid	CASTERS-RR4RIGID	All models
	5" CASTERS 5" Caster kit, 4 swivel with locks	CASTERS-RR4	All models

FACTORY-INSTALLED OPTIONS

Option	For
208/240V, 50/60 Hz Change	VBP, VPT, and VHP Cabinets
Left hand hinged front	VBP, VPT, and VHP Cabinets
Left hand hinged back	All VPT Cabinets
Glass door(s) front	VBP7, VBP15*, VPT7, VPT15*
Glass door(s) rear	VPT7, VPT15*
Knob guard	VBP, VPT, and VHP Cabinets
Full perimeter bumper	VBP, VPT, and VHP Cabinets
Transport latch (includes hasp)	VBP, VPT, and VHP Cabinets

*2 dutch doors



CORRECTIONAL HOLDING CABINETS (INSULATED)



Security, Durability, Performance.

STANDARD FEATURES:

- Electronic control with digital display for holding at temperatures up to 200°F with lockable security cover and viewport.
- Blower fan for gentle and even temperature distribution.
- Solid door with solid hinges.
- 5" heavy duty casters (2 swivel with brakes and 2 rigid).
- Recessed and welded side mounted handles.
- 20-gauge stainless steel exterior and interior.
- Fully insulated 1½" interior left and right walls, and 2" top.
- Magnetic action door latch.
- Rear mounted cord with strain relief.
- 14-gauge lockable transport latch.
- Tamper-resistant fasteners throughout.
- Fully welded removable tray slides
VBP18ES-CBFT has 4" spacing
VBP18ES-CBFT-6 has 6" spacing
- Full perimeter bumper.
- 1-Year limited parts and labor warranty; 10-year parts warranty on heating elements.
- ENERGY STAR® certified.

VBP-CBFT SERIES

Model	Dimensions (W x D x H)	Sheet Pan Capacity	Hotel Pan Capacity	Volts	Watts	Amps
VBP18ES-CBFT	30½" x 36½" x 70"	12	24	120	1,500	12.5
VBP18ES-CBFT-6	30½" x 36½" x 70"	8	16	120	1,500	12.5

Sheet pan = 18" x 26" | Hotel pan = 12" x 20"

FACTORY-INSTALLED OPTION

No racking (stacked trays)



VBP18ES-CBFT



VBP18ES-CBFT-6

VHFA SERIES (NON-INSULATED)

Low volume operations with shorter holding periods.

STANDARD FEATURES:

- Structural components are 100% stainless steel.
- Fixed tray slides on 3" centers.
- Glass door (field reversible).
- (4) 5" casters—2 swivel with locks and 2 rigid.
- Field-reversible doors.



VHFA9



VHFA18

VHFA SERIES

Model	Dimensions (W x D x H)	Sheet Pan Capacity	Volts	Watts	Amps
VHFA9	25¼" x 30¾" x 45"	9	120	1,200	10
VHFA18	25¼" x 30¾" x 71"	18	120	2,000	16.7
VHFA18-IM3PN*	25¼" x 30¾" x 71"	18	120	2,000	16.7

*With 30 amp plug included, required for Canada.

FIELD-INSTALLED ACCESSORIES



DESCRIPTION

CASTERS
3" Caster kit, 2 swivel with locks and 2 rigid

ITEM

CASTERS-3INRR4

FOR

All VHFA models



CASTERS
5" Caster kit, 4 swivel with locks

CASTERS-RR4

All VHFA models

VCH INSTITUTIONAL SERIES

Low temperature cooking.

STANDARD FEATURES:

- Structural components are 100% stainless steel.
- Interior pan supports are removable for easy cleaning.
- Solid state temperature controls.
- 2 wire cooking racks with VCH5 and VCH8; 4 racks with VCH16 and VCH88.
- Set of (4) 5" casters—2 swivel with locks and 2 rigid.
- 208/240V dual voltage, 50/60 Hz, 1 Phase.
- 6' power cord with plug (2 cords with plugs with VCH88).
- 400°F roast thermostat allows for roasting, baking, and rethermalization.
- Low speed convected air browns and caramelizes with reduced shrinkage.
- Digital LED display shows: time, hold temperature, cook temperature, and cabinet temperature.



VCH SERIES

Model	Dimensions (W x D x H)	Sheet Pan Capacity	Hotel Pan Capacity	Volts	Watts (per section)	Amps
VCH5	27¼" x 36½" x 40"	5	10	208/240	1,900/2,530	9.6/11
VCH8	27¼" x 36½" x 59¾"	8	16	208/240	3,800/5,060	19/22
VCH16	27¼" x 36½" x 65¼"	16	32	208/240	5,700/7,590	28/32
VCH88*	27¼" x 36½" x 69½"	16	32	208/240	3,800/5,060	19/22

- Model VCH88 requires 2 separate electrical connections.
- Model VCH88 has 2 sections. All other models have 1.
- Model VCH88 ships with 2 ovens on casters and 1 stacking kit for field installation.
- Sheet pan = 18" x 26" | Hotel pan = 12" x 20"

FACTORY-INSTALLED OPTIONS

Description

- Full Perimeter Bumper
- Left Hand Hinged

FIELD-INSTALLED ACCESSORIES

Item

Description

- RACK-VCH Wire pan grid with feet (each)
- VI/PAN-SLIDES Universal tray slide pair

VRH SERIES



VRH88

8-Pan cook and hold oven with solid doors.

STANDARD FEATURES:

- Structural components are 100% stainless steel.
- Interior pan supports are removable for easy cleaning.
- Mechanical temperature controls.
- 3 wire cooking shelves with VRH8 and 6 shelves with VRH88.
- Set of (4) 5" casters—2 swivel with locks and 2 rigid.
- 208/240V dual voltage, 50/60 Hz, 1 Phase.
- 6' power cord with plug (2 cords with plugs with VRH88).
- 250°F roast thermostat allows for roasting and rethermalization.
- Low speed convected air browns and caramelizes with reduced shrinkage.
- Field-reversible doors.



VRH8

VRH SERIES

Model	Dimensions (W x D x H)	Sheet Pan Capacity	Hotel Pan Capacity	Volts	Watts (per section)	Amps
VRH8	27¼" x 33¼" x 43½"	8	16	208/240	2,250/3,000	10.8/12.5
VRH88*	27¼" x 33¼" x 81"	16	32	208/240	2,250/3,000	10.8/12.5

- Model VRH88 requires 2 separate electrical connections.
- Model VRH88 ships with 2 ovens on casters and 1 stacking kit for field installation.
- Sheet pan = 18" x 26" | Hotel pan = 12" x 20"

FIELD-INSTALLED ACCESSORIES

Item #	Description
STACKIT-VBP-CH	Stacking Kit
TRAYSLD-VRH8	Adjustable Tray Slide Kit
SHELF-VRH8	Wire Shelf for VRH Oven
CASTERS-3INRR4	3" Caster kit—2 swivel with locks and 2 rigid
CASTERS-RR4	5" Caster kit—4 swivel with locks

FACTORY-INSTALLED OPTIONS

Description
Full Perimeter Bumper
Left Hand Hinged

VP SERIES (NON-INSULATED)

Low volume operations with shorter holding periods.

STANDARD FEATURES:

- All components are 100% stainless steel.
- Cabinet provides excellent heat distribution and recovery times.
- Adjustable tray slides.
- Easy-to-use switch to convert proofing to holding mode.
- Half-gallon water pan.
- Drip trough and water collection pan.
- Glass door (field reversible).
- (4) 5" casters—2 swivel with locks and 2 rigid.



VP18

VP SERIES

Model	Dimensions (W x D x H)	Sheet Pan Capacity	Hotel Pan Capacity	Volts	Watts	Amps
VP18-1M3ZN (USA)	25¼" x 30¾" x 71"	18	36	120	2,000	16.7
VP18-IM3PN* (CA)	25¼" x 30¾" x 71"	18	36	120	2,000	16.7

*With 30 amp plug included, required for Canada. Sheet pan = 18" x 26" | Hotel pan = 12" x 20"

FIELD-INSTALLED ACCESSORIES

	DESCRIPTION	ITEM #	FOR
	3" CASTERS 3" Caster kit, 2 swivel with locks and 2 rigid	CASTERS-3INRR4	All VP models
	5" CASTERS 5" Caster kit, 4 swivel with locks	CASTERS-RR4	All VP models
	TRAY SLIDES Universal Tray Slide Pair	VI/PAN-SLIDES	All VP models

VW SERIES

Standard built-in and freestanding models.

STANDARD FEATURES:

- All components are 100% stainless steel.
- Separate heaters and thermostatic controls for each drawer.
- Drawers are removable for easy cleaning.
- 4" adjustable stainless steel legs (field installed).
- Heavy duty drawer frame allows pan to lift up straight.
- Optional trim ring available for built-in applications.



VW2S

VW SERIES

Model	Dimensions (W x D x H)	Hotel Pan Capacity	Volts	Watts	Amps
VW1S	27½" x 23½" x 11¼"	1	120	475	4
VW2S	27½" x 23½" x 20"	2	120	950	8
VW3S	27½" x 23½" x 28¾"	3	120	1,425	12

*Add 5" to the freestanding height with legs installed.
Hotel pan = 12" x 20"*

FACTORY-INSTALLED OPTION

208/240V, 50/60 Hz change

FIELD-INSTALLED ACCESSORIES

Item #	Description
TRIMKIT-VW1S	Trim kit to convert to 1 drawer built-in model
TRIMKIT-VW2S	Trim kit to convert to 2 drawer built-in model
TRIMKIT-VW3S	Trim kit to convert to 3 drawer built-in model
CASTERS-3INRR4SI	3" Caster kit—4 swivel, 2 with locks



TRIMKIT-VW1S

VS SERIES (SLIM-LINE)

Drawer warmers for those tight spaces.

STANDARD FEATURES:

- All components are 100% stainless steel.
- Separate heaters and thermostatic controls for each drawer.
- Drawers are removable for easy cleaning.
- 120 V, 60 Hz, 1 Phase.
- 4" adjustable stainless steel legs (field installed).
- 6' cord and plug.



VS SERIES

Model	Dimensions (W x D x H)	Hotel Pan Capacity	Volts	Watts	Amps
VSL1	20½" x 30½" x 11½"	1	120	475	4
VSL2	20½" x 30½" x 20½"	2	120	950	8

*Add 5" to the freestanding height with legs installed.
Hotel pan = 12" x 20"*

FIELD-INSTALLED ACCESSORIES

Item #	Description
TRIMKIT-VSL1	Trim kit to convert to 1 drawer built-in model
TRIMKIT-VSL2	Trim kit to convert to 2 drawer built-in model
WP1143SI-CASTER	3" Caster kit - 4 swivel, 2 with brakes

VCW SERIES

Nacho and tortilla chip warmer for warm and fresh chips.

STANDARD FEATURES:

- Top-load style.
- First-in / first-out design.
- 26- and 46-gallon capacities.
- Adjustable thermostat with easy-to-use on/off switch.
- 1,500 watts for fast heating (VCW46).



VCW46

VCW SERIES

Model	Dimensions (W x D x H)	Capacity Gallons	Volts	Watts	Amps
VCW26	20½" x 30½" x 30½"	26	120	1,000	8.3
VCW46	20½" x 30½" x 38"	46	120	1,500	12.5

Add 5" to the freestanding height with legs installed.



VCW26



VCW46



FREE Vulcan New Equipment Checkout

A PARTNERSHIP WITH HOBART & AUTHORIZED WARRANTY SERVICE PROVIDERS

To ensure new Vulcan equipment has been properly installed and is operating correctly, an authorized service technician will:

- Verify that the proper gas type (LP or natural) has been connected to the equipment.
- Verify that the proper voltage and electrical connections have been made.
- Verify that proper pressure regulators have been installed and adjusted, when applicable.
- Verify that gas supply size and pressure are adequate.
- Verify that proper water, steam, drain supplies and connections have been made.
- Check pilot and burner adjustments.
- Verify thermostat operation, including calibration, when required.
- Check functional parts of operation, for example: doors, lids, valves, etc.
- Advise on preventive maintenance procedures.
- Equipment must be completely installed and ready to operate before the equipment checkout request is made.
- Equipment checkout should be completed within 90 days after installation.

Note: Excludes combi ovens. This program is subject to change. Please contact your Vulcan sales representative for more information.

To schedule your FREE* CHECKOUT, please contact your Sales Representative!

**Purchaser is responsible for time and travel charges in excess of 50 miles (100 miles round trip) of an authorized service agency.*



PROTECT YOUR INVESTMENT!

*Enhance Performance and Efficiency with OEM Parts
for all your Vulcan Equipment.*

*Generic parts are not suitable for your equipment. Protect your investment with genuine
Original Equipment Manufactured parts.*

WHY USE OEM PARTS?

RELIABILITY

Designed specifically for your equipment to provide maximum performance and the most uptime.

AVAILABILITY

Currently available from hundreds of Hobart and Authorized Parts and Service Agencies.

WARRANTY PROTECTION

Keeps your equipment under product warranty and saves you money when repairs are needed.

ENERGY SAVINGS

Designed and tested for exact equipment specifications to work more efficiently, resulting in energy savings over time.



Locate an Authorized Parts or Service Center
vulcanequipment.com/service

Order Parts Online
hobartparts.com | 877.333.1863

TERMS AND CONDITIONS / WARRANTY

TERMS OF SALE

Sales of all items listed herein and all other products and services sold by Vulcan, a division of ITW Food Equipment Group LLC (“Vulcan”), are expressly limited to and made conditional on acceptance of its current terms and conditions of sale, found at <https://www.vulcanequipment.com/notices-and-terms#terms-of-sale> (“Vulcan Terms”), which are incorporated herein by reference. Any additional or different terms are hereby rejected. Commencement of work by Vulcan or acceptance of delivery of products by purchaser constitutes purchaser’s acceptance of the Vulcan Terms.

Vulcan FEG is not responsible for typographical/photographical errors.

WARRANTY INFORMATION



View Limited Original Commercial Equipment Warranty at <https://vulcanequip.co/warranty>



Continuous improvements and product additions are regularly made to the digital version of this catalog. Scan for latest updates.

VULCAN

vulcanequipment.com

800.814.2028