



**QUICKFRY™ SERIES**  
**2VHG70F, 3VHG70F, 4VHG70F**  
 Battery Gas Fryer With KleenScreen PLUS®  
 Built-in Filtering System



2VHG70CF



**SPECIFIER STATEMENT**

Built-in filter system, Vulcan Model No. (# of fryers, 2, 3, 4) VHG70 (control type A, D or C) F (add suffix-F to fryer battery Model No., i.e. 2VHG70DF). Filter system accommodates maximum of four cabinets. Filter vessel constructed of 16-gauge stainless steel. Filter pan weighs 18 lbs. ½ H.P. motor/pump circulates hot frying compound at the rate of 8 gallons per minute (60 Hz), activated by a one touch push button switch. System provided standard with stainless steel mesh filter screen. Optional micro-filtration conversion kit (CONVKIT-2) filter out particulate down to 0.5 microns. Dry fire prevention safety sequence comes standard on all VHG70 models. Standard equipment comes on adjustable casters, has a tank brush and clean-out rod. Hands free oil return line connection. Drain valve interlock switch turns fryer's burners off when drain valve is opened. Requires 120 volt, 50/60 Hz, 1 phase power supply. CSA design certified. NSF listed.

SELL SHEET

Project \_\_\_\_\_  
 AIA # \_\_\_\_\_ SIS # \_\_\_\_\_  
 Item # \_\_\_\_\_ Quantity \_\_\_\_\_ C.S.I. Section 114000

**MODELS**

- VHG70AF:** Solid state knob control with digital character display behind the access panel. Accurate temperature control 150-390°F (66-199°C). Electronic ignition. Digital temperatures: Fahrenheit or Celsius. Three melt modes.
- VHG70DF:** Accurate temperature control 150-390°F (66-199°C) with digital display. Cook with compensating time or actual time. Electronic ignition. Digital temperatures: Fahrenheit or Celsius. Three melt modes. Two count-down timers. Auto and manual boil-out mode.
- VHG70CF:** Programmable computer controls with digital character display. 18 menu timers display product name and cook times. Optional single, dual and triple lane. Offline programming of menu items uploaded through USB interface, software included. Menu can also be downloaded from control onto USB. Accurate temperature control 150-390°F (66-199°C) with digital display. Cook with compensating time or actual time. Electronic ignition. Digital temperatures: Fahrenheit or Celsius. Three melt modes. Auto and manual boil-out mode.

**STANDARD FEATURES**

- Stainless steel cabinet and fry tank; Includes 10-year limited tank warranty
- Drain valve interlock switch (turns off gas burners automatically when draining oil)
- 1¼" full port ball type drain valve
- 6" adjustable casters (locking and non-locking)
- Twin fry baskets with plastic coated handles
- Input rate is 110,000 BTU/hr. for natural gas and 100,000 BTU/hr. for propane
- Hi-limit shut-off
- Electronic matchless ignition
- Tank brush and clean-out rod
- Dry fire prevention safety sequence
- 120 volts, 50/60 Hz, 1 phase (NEMA 5-15P)
- One touch push button switch to engage pump and motor
- 16 gauge stainless steel filter pan; 90 lbs. frying compound capacity
- Stainless steel filter mesh screen filters from 2 sides; filter area = 462 square inches
- ½ H.P. motor and pump circulates frying compound at a rate of 8.0 gallons per minute (60 Hz)
- 6' high temperature discard hose
- One year limited parts and labor warranty

*Accessories and options on next page*

Approved by \_\_\_\_\_ Date \_\_\_\_\_ Approved by \_\_\_\_\_ Date \_\_\_\_\_

QUICKFRY™ SERIES 2VHG70F, 3VHG70F, 4VHG70F Battery Gas Fryer With KleenScreen PLUS® Built-In Filtering System

### TYPE OF GAS

Specify type of gas when ordering:

- Natural Gas**
- Propane Gas**

### ALTITUDE

Specify altitude when ordering:

- Specify **Natural** above 2,000 ft.
- Specify **Propane** above 5,000 ft.

### ACCESSORIES (PACKAGED AND SOLD SEPARATELY)



- 11/4QDH-4FT** 1¼" x 4' Flexible gas hose with quick disconnect



- COVER-TANKVHG70** Stainless steel tank cover, doubles as a work surface top



- BASKETS-TWIN65** Twin baskets for 70lb fryers



- BASKETS-TRI70** Tri baskets for 70lb fryers



- BASKET-1TK65** Single large basket with handles



- VSPGUARD-VHG70** 10" high stainless steel removable splash guard



- VHG70CRUMB-SCREEN** Crumb screen mesh with handles

Image N/A

- CONNECT-KITVHG70** Connecting kit for securing 2 or more fryers together. Includes grease strip and connecting hardware.



- CONVKIT-2** Micro-filtration conversion kit filters particles down to .5 microns. Contains 3 filter envelopes, stainless steel mesh insert and clip



- REFILLKIT-2** Micro-filtration fabric filter envelopes refill (6-pack)

### OPTIONS

- Rear oil reclamation discard connection (factory installed)
- Second year extended limited parts and labor warranty
- Heat Trace

## INSTALLATION INSTRUCTIONS

- A combination valve with pressure regulator is provided with this unit.
  - Natural Gas  
 Operating pressure – 3.5" W.C.  
 Recommended supply pressure 7-9" W.C.  
 Not to exceed 14" W.C. (1/2 PSI)
  - Propane Gas  
 Operating pressure – 10.0" W.C.  
 Recommended supply pressure 11-12" W.C.  
 Not to exceed 14" W.C. (1/2 PSI)
- An adequate ventilation system is required for Commercial Cooking Equipment. Information may be obtained by writing to the National Fire Protection Association, Batterymarch Park, Quincy, MA 02269. When writing refer to NFPA No. 96.
- All models require a 6" (152 mm) clearance at both sides and rear adjacent to combustible construction.
- All models require a 16" (407 mm) minimum clearance to adjacent open top burner units.
- This appliance is manufactured for commercial installation only and is not intended for home use.

### SERVICE CONNECTIONS:

- (P1)** 1¼" NPT-F rear gas connection.
- (E1)** NEMA 5-15P 120 volt cord & plug supplied with fryers (120 volts only). IEC320 C14 receptacle (120 volts).

## 2VHG70F

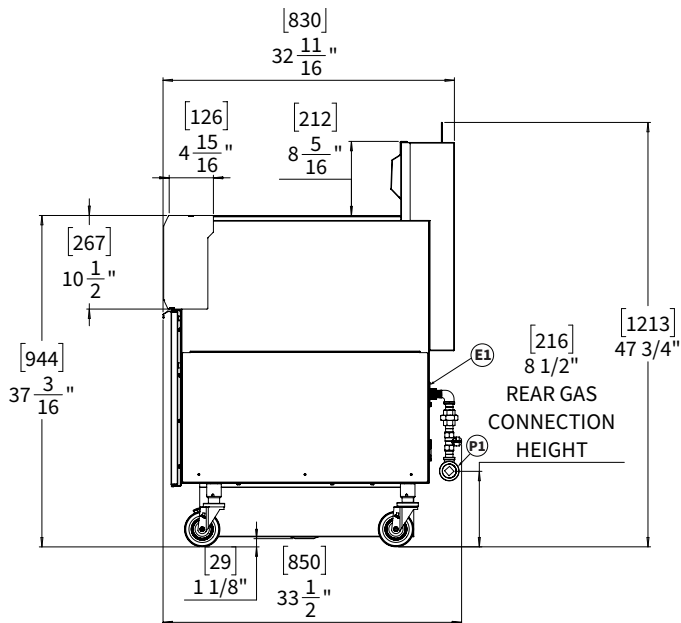
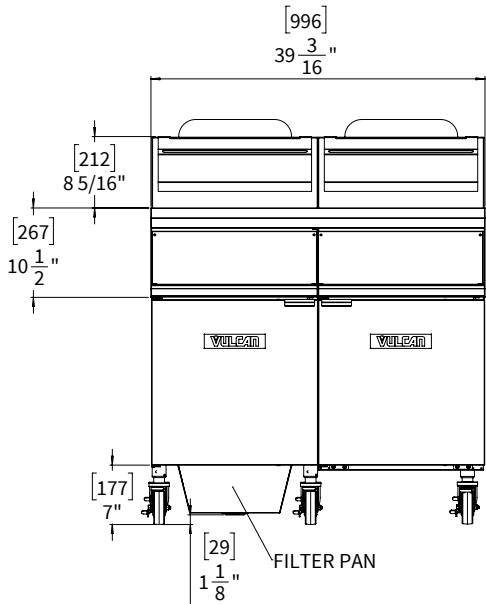
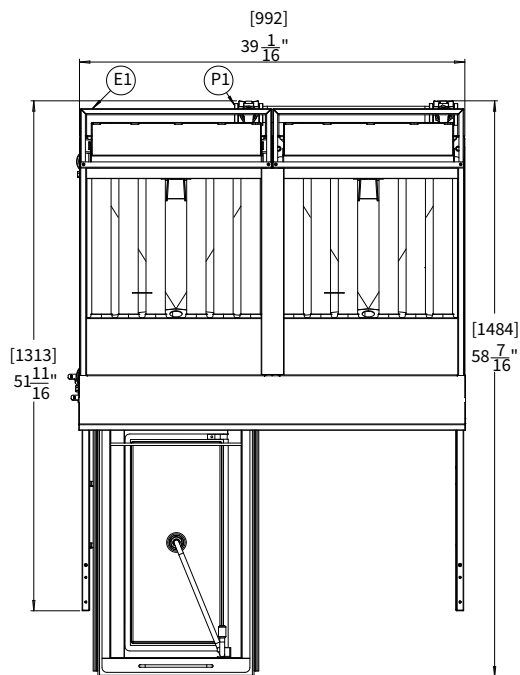

### Individual Fryer Specifications

Model	Frying Area	Oil Depth	Oil Capacity	BTU/hr.
VHG70	18 3/8" x 14 3/8"	4 1/2"	70 lbs.	110,000 Nat. Gas 100,000 Propane

[CAD and/or Revit Files Available](#)

Model	Production lbs./hr. per tank	Filter Pan Capacity	Filter Area Stainless Steel Fabric Envelope	Motor	Pump	Electric Power	Electric Amps
2VHG70F	111 lbs.	90 lbs.	462 sq. in	1725 RPM	8 Gal/Min	120V 50/60Hz 1Ph	7.2A

As continued product improvement is a policy of Vulcan, specifications are subject to change without notice.

## INSTALLATION INSTRUCTIONS

- A combination valve with pressure regulator is provided with this unit.
  - Natural Gas  
 Operating pressure – 3.5" W.C.  
 Recommended supply pressure 7-9" W.C.  
 Not to exceed 14" W.C. (1/2 PSI)
  - Propane Gas  
 Operating pressure – 10.0" W.C.  
 Recommended supply pressure 11-12" W.C.  
 Not to exceed 14" W.C. (1/2 PSI)
- An adequate ventilation system is required for Commercial Cooking Equipment. Information may be obtained by writing to the National Fire Protection Association, Batterymarch Park, Quincy, MA 02269. When writing refer to NFPA No. 96.
- All models require a 6" (152 mm) clearance at both sides and rear adjacent to combustible construction.
- All models require a 16" (407 mm) minimum clearance to adjacent open top burner units.
- This appliance is manufactured for commercial installation only and is not intended for home use.

### SERVICE CONNECTIONS:

- (P1)** 1/4" NPT-F rear gas connection.
- (E1)** NEMA 5-15P 120 volt cord & plug supplied with fryers (120 volts only). IEC320 C14 receptacle (120 volts).

**3VHG70F**

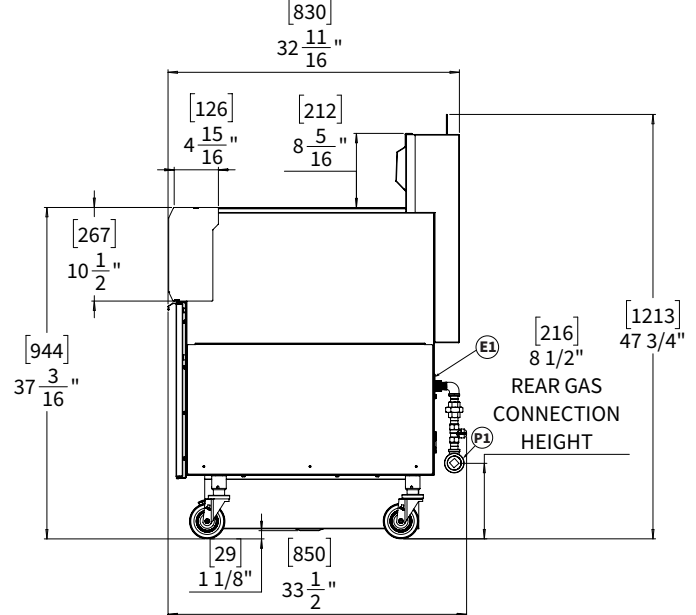
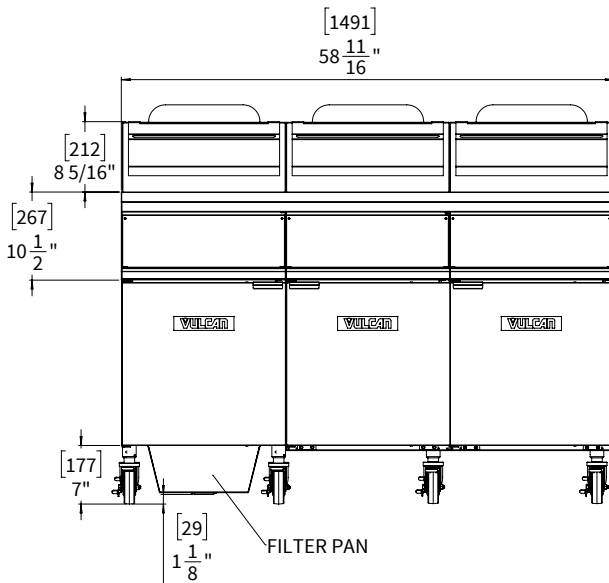
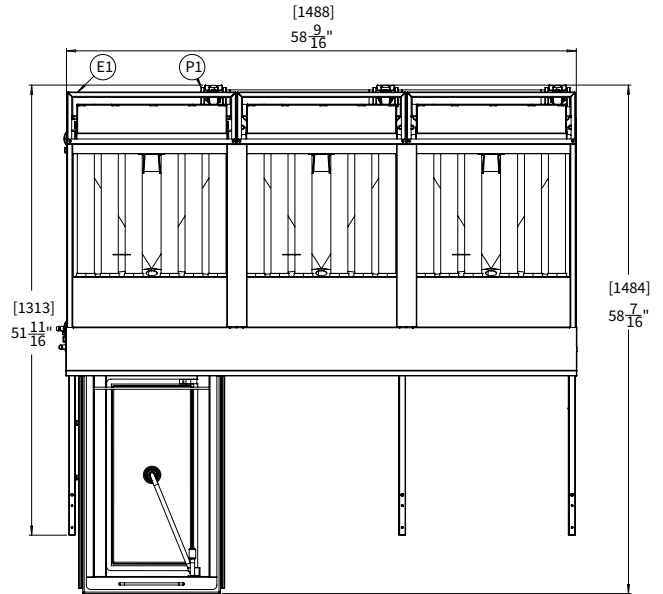

### Individual Fryer Specifications

Model	Frying Area	Oil Depth	Oil Capacity	BTU/hr.
VHG70	18 1/8" x 14 1/8"	4 1/2"	70 lbs.	110,000 Nat. Gas 100,000 Propane

[CAD and/or Revit Files Available](#)

Model	Production lbs./hr. per tank	Filter Pan Capacity	Filter Area Stainless Steel Fabric Envelope	Motor	Pump	Electric Power	Electric Amps
3VHG70F	111 lbs.	90 lbs.	462 sq. in	1725 RPM	8 Gal/Min	120V 50/60Hz 1Ph	7.5A

As continued product improvement is a policy of Vulcan, specifications are subject to change without notice.

## INSTALLATION INSTRUCTIONS

- A combination valve with pressure regulator is provided with this unit.
  - Natural Gas  
 Operating pressure – 3.5" W.C.  
 Recommended supply pressure 7-9" W.C.  
 Not to exceed 14" W.C. (1/2 PSI)
  - Propane Gas  
 Operating pressure – 10.0" W.C.  
 Recommended supply pressure 11-12" W.C.  
 Not to exceed 14" W.C. (1/2 PSI)
- An adequate ventilation system is required for Commercial Cooking Equipment. Information may be obtained by writing to the National Fire Protection Association, Batterymarch Park, Quincy, MA 02269. When writing refer to NFPA No. 96.
- All models require a 6" (152 mm) clearance at both sides and rear adjacent to combustible construction.
- All models require a 16" (407 mm) minimum clearance to adjacent open top burner units.
- This appliance is manufactured for commercial installation only and is not intended for home use.

### SERVICE CONNECTIONS:

- (P1)** 1¼" NPT-F rear gas connection.
- (E1)** NEMA 5-15P 120 volt cord & plug supplied with fryers (120 volts only). IEC320 C14 receptacle.

## 4VHG70F

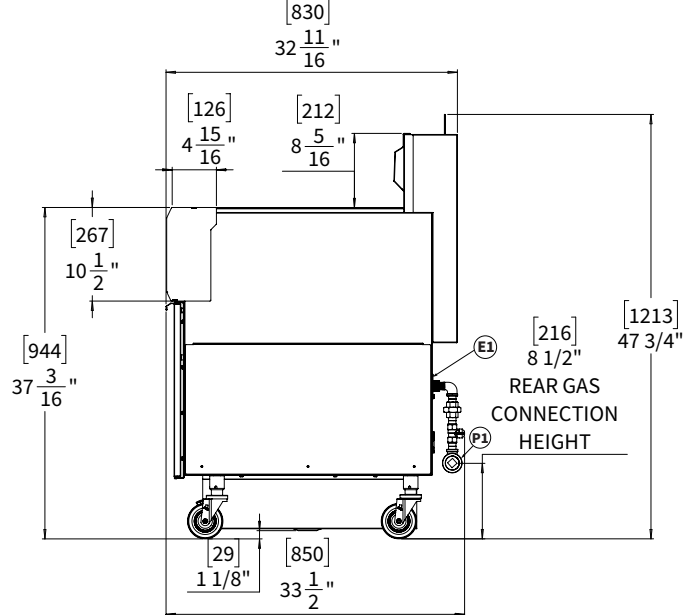
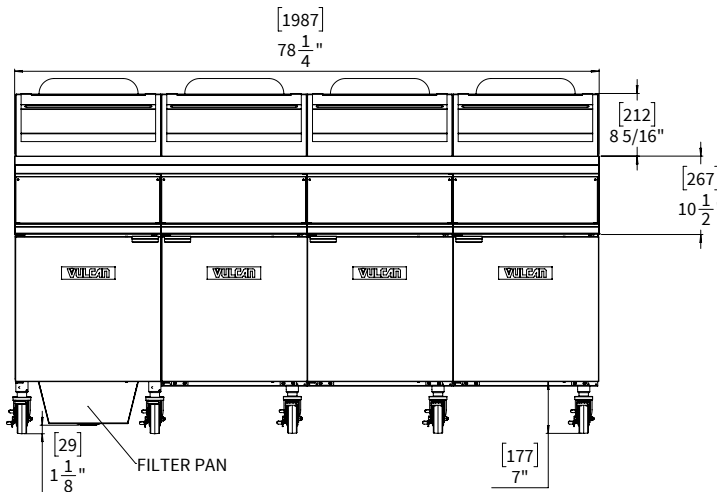
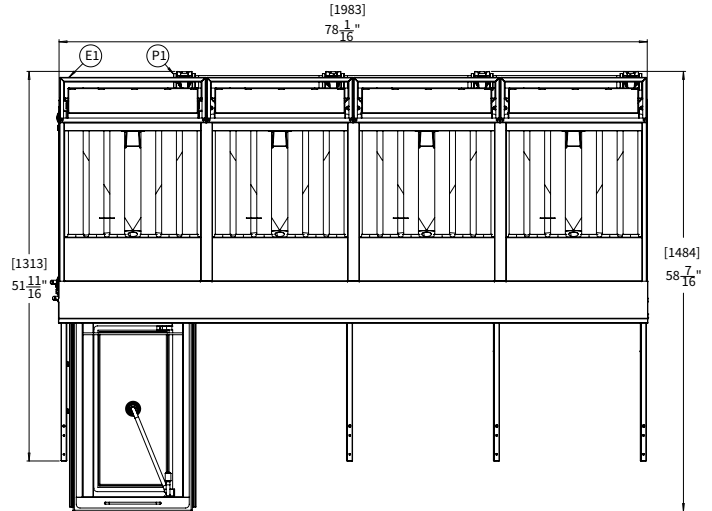

### Individual Fryer Specifications

Model	Frying Area	Oil Depth	Oil Capacity	BTU/hr.
VHG70	18 1/8" x 14 1/8"	4 1/2"	70 lbs.	110,000 Nat. Gas 100,000 Propane

[CAD and/or Revit Files Available](#)

Model	Production lbs./hr. per tank	Filter Pan Capacity	Filter Area Stainless Steel Fabric Envelope	Motor	Pump	Electric Power	Electric Amps
4VHG70F	111 lbs.	90 lbs.	462 sq. in	1725 RPM	8 Gal/Min	120V 50/60Hz 1Ph	7.8A

As continued product improvement is a policy of Vulcan, specifications are subject to change without notice.