

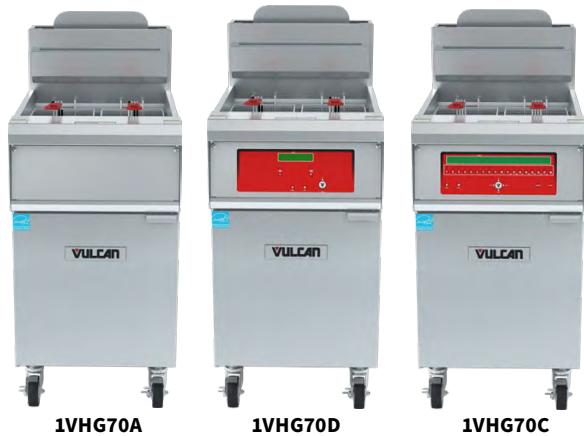

QUICKFRY™ SERIES 1VHG70

Free Standing Gas Fryers



SPECIFIER STATEMENT

70 lb. capacity free standing gas fryer, Vulcan Model No. (1VHG70A), (1VHG70D), (1VHG70C). Stainless steel cabinet. Set of four 6" adjustable casters (2 locking). Stainless steel fry tank with six heat exchanger tubes. ENERGY STAR® certified. 1¼" full port ball type drain valve. Twin fry baskets with plastic coated handles. Input rate is 110,000 BTU/hr. for natural gas and 100,000 BTU/hr. for propane. Solid state analog knob control, digital or programmable computer control systems all standard with electronic matchless ignition. Tank brush and clean-out rod included. Dry fire prevention safety sequence comes standard on all 1VHG70 models. Drain valve interlock switch turns fryer's burners off when drain valve is opened. Requires 120 volt, 50/60 Hz, 1 phase power supply.

Overall Dimensions:

19¹/₁₆"W x 32¹/₁₆"D x 47³/₁₆"H. Working height 37³/₁₆". CSA design certified. NSF listed.

SELL SHEET

Project _____
AIA # _____ SIS # _____
Item # _____ Quantity _____ C.S.I. Section 114000

MODELS

- 1VHG70A:** Solid state analog knob control with digital character display behind the access panel. Accurate temperature control 150-390°F (66-199°C). Electronic ignition. Digital temperature display: Fahrenheit or Celsius. Three melt modes.
- 1VHG70D:** Accurate temperature control 150-390°F (66-199°C) with digital display. Cook with compensating time or actual time. Electronic ignition. Digital temperatures: Fahrenheit or Celsius. Three melt modes. Two count-down timers. Auto and manual boil-out mode.
- 1VHG70C:** Programmable computer controls with digital character display. 18 menu timers display product name and cook times. Optional single, dual and triple lane. Offline programming of menu items uploaded through USB interface, software included. Menu can also be downloaded from control onto USB. Accurate temperature control 150-390°F (66-199°C) with digital display. Cook with compensating time or actual time. Electronic ignition. Digital temperatures: Fahrenheit or Celsius. Three melt modes. Auto and manual boil-out mode.

STANDARD FEATURES

- Stainless steel cabinet and fry tank, 70 lb. capacity; Includes 10-year limited tank warranty
- Drain valve interlock switch (turns off gas burners automatically when draining oil)
- 1¼" full port ball type drain valve
- Set of four 6" adjustable casters (2 locking)
- Twin fry baskets with plastic coated handles
- Input rate is 110,000 BTU/hr. for natural gas and 100,000 BTU/hr. for propane
- Hi-limit shut-off
- Electronic matchless ignition
- Tank brush and clean-out rod
- Dry fire prevention safety sequence
- 120 volts, 50/60 Hz, 1 phase (NEMA 5-15P)
- One year limited parts and labor warranty

Accessories and options on next page

QUICKFRY™ SERIES - 1VHG70 Free Standing Gas Fryer

Approved by _____ Date _____ Approved by _____ Date _____

TYPE OF GAS

Specify type of gas when ordering:

- Natural Gas**
- Propane Gas**

ALTITUDE

Specify altitude when ordering:

- Specify **Natural** above 2,000 ft.
- Specify **Propane** above 5,000 ft.

ACCESSORIES (PACKAGED AND SOLD SEPARATELY)



- 3/4QD-HOSE-4** ¾" x 4' Flexible gas hose with quick disconnect



- COVER-TANKVHG70** Stainless steel tank cover, doubles as a work surface top



- BASKETS-TWIN65** Twin baskets for 70lb fryers



- BASKETS-TRI70** Tri baskets for 70lb fryers



- BASKET-1TK65** Single large basket with handles



- VSPGUARD-VHG70** 10" high stainless steel removable splash guard



- VHG70CRUMB-SCREEN** Crumb screen mesh with handles

Image N/A

- CONNECT-KITVHG70** Connecting kit for securing 2 or more fryers together. Includes grease strip and connecting hardware.

OPTIONS

- Second year extended limited parts and labor warranty

INSTALLATION INSTRUCTIONS

- A combination valve with pressure regulator is provided with this unit.
 - Natural Gas
Operating pressure – 3.5" W.C.
Recommended supply pressure 7-9" W.C.
Not to exceed 14" W.C. (1/2 PSI)
 - Propane Gas
Operating pressure – 10.0" W.C.
Recommended supply pressure 11-12" W.C.
Not to exceed 14" W.C. (1/2 PSI)
- An adequate ventilation system is required for Commercial Cooking Equipment. Information may be obtained by writing to the National Fire Protection Association, Batterymarch Park, Quincy, MA 02269. When writing refer to NFPA No. 96.

- All models require a 6" (152 mm) clearance at both sides and rear adjacent to combustible construction.
- All models require a 16" (407 mm) minimum clearance to adjacent open top burner units.
- This appliance is manufactured for commercial installation only and is not intended for home use.

SERVICE CONNECTIONS:

- Ⓜ 1/2" (13 mm) ID and 3/4" (19 mm) OD rear gas connection.
- Ⓜ NEMA 5-15P 120 volt cord & plug supplied with fryers (120 volts only).
IEC320 C14 receptacle.

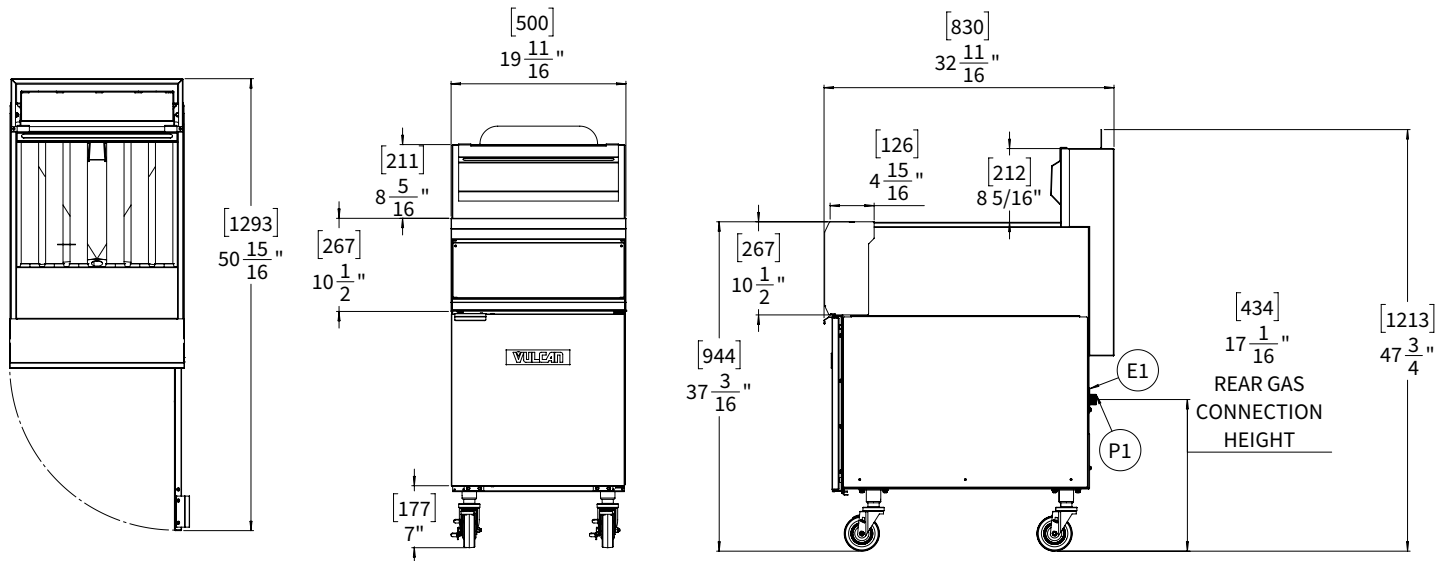

[CAD and/or Revit Files Available](#)

Fryer Specifications

Model	Production lbs./hr.	Frying Area	Oil Depth	Oil Capacity	Electric Power	Electric Amps
1VHG70	111 lbs.	18 7/8" x 14 1/8"	4 1/2"	70 lbs.	120V 50/60Hz 1Ph	0.3A

Model	Width	Depth	Overall Height	Working Height	BTU/hr.	Approximate Shipping Weight
1VHG70	19 1/16"	32 1/16"	47 3/4"	37 3/16"	110,000 (Natural Gas) 100,000 (Propane)	275 lbs.