



The Signature of Quality®

FEDERAL INDUSTRIES

A Standex Company

215 Federal Avenue
Belleville, Wisconsin 53508-9201

Phone: 800-356-4206

Fax: 608-424-3234

Email: Geninfo@Federalind.com

Website: Federalind.com

Project Name: _____

Item #: _____

Model #: _____ Qty: _____

Approval: _____

AIA #

SIS #

VISION SERIES - Curved End Self-Serve Non- Refrigerated Merchandiser - 60"

Designed with impulse sales in mind. Get maximum return from an attention-grabbing merchandiser and increase profits.



Model VNSS3660C

Shown with Options

MODEL	DIMENSIONS (Includes End Panels)
<input type="checkbox"/> VNSS3660C	36 x 33 x 60 (in) 914 x 838 x 1524 (mm)
<input type="checkbox"/> VNSS4860C	47.25 x 33 x 60 (in) 1200 x 838 x 1524 (mm)
<input type="checkbox"/> VNSS6060C	59.25 x 33 x 60 (in) 1505 x 838 x 1524 (mm)
<input type="checkbox"/> VNSS7260C	71.25 x 33 x 60 (in) 1810 x 838 x 1524 (mm)

STANDARD FEATURES

Model Features

- Black interior including shelves
- Stainless steel display deck
- Black powder coated base frame
- Tempered glass ends
- Moisture resistant end panel construction
- Choice of six standard colors on lower millwork panel
- Black trim
- Adjustable leg levelers
- Matches profile of the VRSS & VHSS models

Shelving

- Two tiers of adjustable black metal shelves with price tag molding. Shelves can be flat or slanted downwards at 10°

Lighting

- 3500K LED top light

Agency Approvals

- UL, C-UL, NSF2

OPTIONAL ACCESSORIES

- 3500K LED lights below shelves
- White interior (including shelves)
- Stainless steel interior (including shelves)
- Stainless steel shelves in lieu of black
- Deli meat pegs
- Additional lighted 3500K LED shelf
- Special exterior laminate finish
- Graphics Package
- Stainless steel exterior finish
- Solid right/left end panels (mirrored)
- Reflective end glass
- Clear or reflective sliding rear doors (solid hinged on 36" cases)
- Front cart bumper
- Recessed casters
- 2 1/2" or 4" casters
- Legs, 6"
- Seismic legs
- Skirt w/4" casters or legs
- Joining kit for continuous line-ups
- Front wire display basket
- Roll-down locking security cover (square end profile only)
- Black polycarbonate removable locking security cover

*Additional options available on the website and price list.



WARRANTY*
One year Parts and Labor
2nd thru 5th year part only
service compressor
(U.S.A. and Canada)

Note: Information is subject to change at any time. Visit www.federalind.com for the most current specs.

AIA #	VISION SERIES - Curved End Self-Serve Non- Refrigerated Merchandiser - 60"
SIS #	Product Specifications

Zone	Intended Product To Be Displayed
All	Non-Refrigerated Package Products

DIMENSION: xx"/(mm)
DIMENSION TOLERANCE +/- 0.25 (6.4)

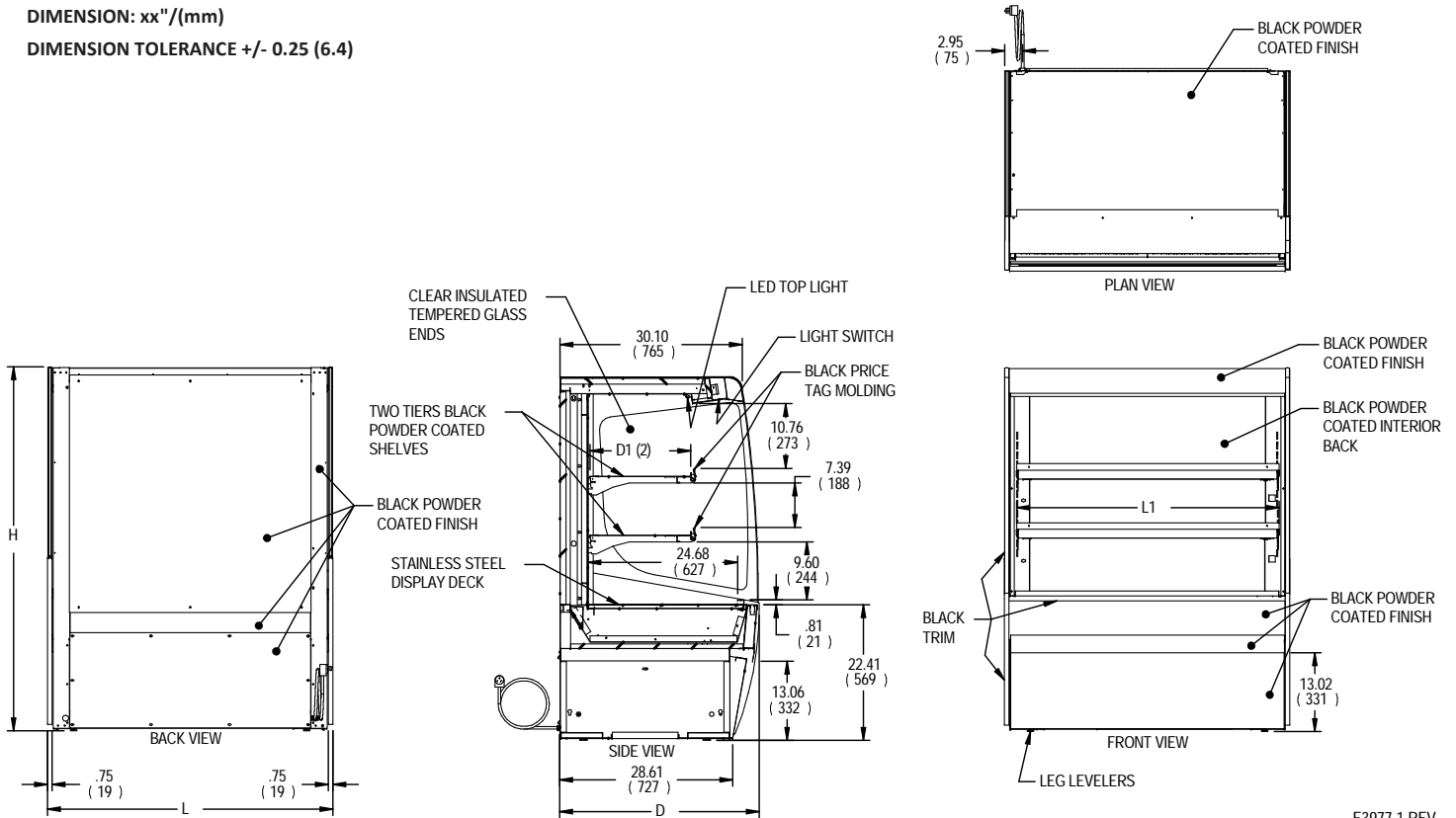

E3977-1 REV -

MODEL	DIMENSIONS			# OF TIERS	SHELVING		INTERIOR VOLUME CU FT	STANDARD CONNECTION CORD & PLUG			SHIP WEIGHT
	L	D	H		L1	D1		2 WIRE + GROUND		NEMA CORD & PLUG	
	in	in	in		in	in		120/60/1			
	mm	mm	mm		mm	mm		AMPS	MAX FUSE SIZE	KILO	
VNSS3660C	36	33	60	2	32.25	16.634	13.98	1.5	15	NEMA 5-15P	LBS
	914	838	1524		819	423					202
VNSS4860C	47.25	33	60	2	43.25	16.634	18.48	1.5	15	NEMA 5-15P	LBS
	1200	838	1524		1099	423					243
VNSS6060C	59.25	33	60	2	55.25	16.634	23.39	2.0	15	NEMA 5-15P	LBS
	1505	838	1524		1403	423					302
VNSS7260C	71.25	33	60	2	67.25	16.634	28.30	2.0	15	NEMA 5-15P	LBS
	1810	838	1524		1708	423					342

• Due to continuing engineering improvements, specifications are subject to change without notice



ANSI/NSF 2



FEDERAL INDUSTRIES
 A Standex Company
 215 Federal Avenue Belleville, Wisconsin 53508-9201

Phone: 800-356-4206
Fax: 608-424-3234
Email: Geninfo@Federalind.com
Website: Federalind.com