

PRODUCT SPECIFICATIONS

Elkay Pro Filtration™ Bottle Filling Station & Single ADA Cooler Refrig Ultra-Capacity Lead Reduction BK. Chilling Capacity of 8.0 GPH (gallons per hour) of 50° F drinking water, based on 80° F inlet water and 90° F ambient, per ASHRAE 18 testing. Features shall include Antimicrobial*, Automatic Filter Status Reset, Energy Savings, Filtered, Green Ticker™, Hands Free, Laminar Flow, Real Drain, Visual Filter Monitor, Alcove Light, Automatic Filter Flush, Stainless Steel Alcove, Pro Filtration System, Top Mount Quick Filter Change. Furnished with Flexi-Guard® Safety Bubbler. Electronic Bottle Filler Sensor with Electronic Front and Side Bubbler Pushbar activation. Product shall be Wall Mount (On Wall), for Indoor applications, serving 1 station(s). Unit shall be certified to UL 399 and CAN/CSA C22.2 No. 120.



Special Features:	Antimicrobial, Automatic Filter Status Reset, Energy Savings, Filtered, Green Ticker™, Hands Free, Laminar Flow, Real Drain, Visual Filter Monitor, Alcove Light, Automatic Filter Flush, Stainless Steel Alcove, Pro Filtration System, Top Mount Quick Filter Change
Finish:	Black Stainless (BK)
Power:	115V/60Hz
Bubbler Style:	Flexi-Guard® Safety Bubbler
Activation by:	Electronic Bottle Filler Sensor with Electronic Front and Side Bubbler Pushbar
Mounting Type:	Wall Mount (On Wall)
Chilling Capacity*:	8.0 GPH
Full Load Amps	5
Dimensions (L x W x H):	18-3/8" x 19" x 46-7/8"
Approx. Shipping Weight:	79 lbs.
Installation Location:	Indoor
No. of Stations Served:	1

*Based on 80° F inlet water & 90° F ambient air temp for 50° F chilled drinking water.

Included with Product: Bottle Filler, Water Cooler, Ultra Capacity Filter

Ships in one box.
A Century of Tradition and Quality. For more than 100 years, Elkay has been making innovative products and providing exceptional customer care. We take pride in offering plumbing products that make life easier, inspire change and leave the world a better place.



PRODUCT COMPLIANCE

- ADA & ICC A117.1
- ASME A112.19.3/CSA B45.4
- CAN/CSA C22.2 No. 120
- FCC & ISED
- NSF/ANSI 42, 53, 61 (Q≤1), 372 (lead free), & 401
- UL 399



This Zurn Elkay product has a certified Environmental Product Declaration (EPD) that complies with an independently verified life cycle assessment (LCA). Visit [Product Declarations and Certifications](#) for more information.

 Complies with ADA & ICC A117.1 accessibility requirements when installed according to the requirements outlined in these standards. Installation may require additional components and/or construction features to be fully compliant. Consult the local Authority Having Jurisdiction if necessary.

[Installation Instructions \(PDF\) - 200002266](#)

5 Year Limited Warranty on the refrigeration system of the unit. Electrical components and water system are warranted for 12 months from date of installation. **Warranty pertains to drinking water applications only. Non-drinking water applications are not covered under warranty.**

[Warranty \(PDF\)](#)

PART: _____ QTY: _____
 PROJECT: _____
 CONTACT: _____
 DATE: _____
 NOTES: _____ APP
 ROVAL: _____

In keeping with our policy of continuing product improvement, Elkay reserves the right to change product specifications without notice. Please visit [elkay.com](#) for the most current version of Elkay product specification sheets. This specification describes an Elkay product with design, quality, and functional benefits to the user. When making a comparison of other producers' offerings, be certain these features are not overlooked.



Model LZS8WSBPRO

Elkay Pro Filtration™ Bottle Filling Station & Single ADA Cooler
Refrig Ultra-Capacity Lead Reduction BK

TAG

Features	
<ul style="list-style-type: none"> High-Performance System: Pairs exclusively with Elkay Pro Filtration filters to deliver safer drinking water 	<ul style="list-style-type: none"> Faster Filter Changes: Replace filters easily and more efficiently at the top of the unit
<ul style="list-style-type: none"> Save Time and Resources: Top of unit houses both a stage 1 sediment prefilter and long-lasting contaminant filter for simplified maintenance 	<ul style="list-style-type: none"> Ultra-Capacity Filter Included: Elkay Pro Filtration 10,000-gallon filter is tested and certified to NSF/ANSI 42, 53 and 401 to reduce lead, microplastics and more; ideal for high-traffic areas
<ul style="list-style-type: none"> Automatic Filter Recognition: Elkay Pro Filtration system recognizes new filter and automatically resets filter status lights, shortening installation time 	<ul style="list-style-type: none"> Automatic Filter Flushing: System detects newly installed filters and automatically flushes the system to shorten installation time and clean debris and air from the waterway
<ul style="list-style-type: none"> Never Miss a Filter Change: The intuitive blue LCD filter life gauge instills confidence in users who can easily see remaining filter capacity. 	<ul style="list-style-type: none"> Elevated Design: Sleek, architectural design takes up little space and features innovative functionality for a minimalist, modern aesthetic
<ul style="list-style-type: none"> Smart Connected Units: Save time and resources when you track filter status, monitor performance, anticipate maintenance and flush the unit from anywhere. 	<ul style="list-style-type: none"> Sustainable Choice: Drink water sustainably; view number of 20-ounce plastic water bottles saved from waste and ounces dispensed on the unit's display
<ul style="list-style-type: none"> Energy and Cost Efficient: Hermetically sealed refrigeration system conserving energy and lowering operating costs 	<ul style="list-style-type: none"> Cleaner Basin: Real drain system eliminates standing water
<ul style="list-style-type: none"> Touchless Bottle Filling: Sensor-activated bottle filler delivers 20 ounces of water for an effortless, more hygienic experience 	<ul style="list-style-type: none"> Quick Fill: Bottle fill rate and filter flow rate match at 1.0 GPM for a quick fill, and laminar flow feature minimizes splash, while providing a clear stream of water
<ul style="list-style-type: none"> Tempered Glass Display: Designed for high-traffic environments to withstand impact and protect long-term performance. 	<ul style="list-style-type: none"> *Antimicrobial claims are in reference to components manufactured antimicrobial agents, helping to provide clean, stain- and odor-free surfaces.

Filtration Options	Suffix	Description	Filters Included
Total PFAS + Lead	-FLP4	Elkay Pro Filtration® 4,000 gallon Total PFAS and Lead filter is certified by IAPMO R&T to NSF/ANSI 42, 53 and 401 to reduce Total PFAS, lead, microplastics, cysts, asbestos, turbidity, particulate class 1, chlorine, and taste and odor, and to NSF/ANSI/CAN 372 for lead free compliance.	FLP4
Sediment Prefilter	-FSR5	Elkay Pro Filtration® Sediment Prefilter is certified by IAPMO R&T to NSF/ANSI 42 for material safety and structural integrity only, and to NSF/ANSI/CAN 372 for lead free compliance.	FL10 + FSR5
UV	-UV	Units are equipped with a built-in UVC-LED at the dispense point.	FL10

Optional Accessories

FL6	Elkay Pro Filtration® High-Capacity Lead + Microplastics 6000 gal. Filter	Spec Sheet (PDF)
FLP4	Elkay Pro Filtration® Total PFAS* + Lead + Microplastics 4000 gal. Filter	Spec Sheet (PDF)
FL10	Elkay Pro Filtration® Ultra-Capacity Lead + Microplastics 10000 gal. Filter	Spec Sheet (PDF)
FSR5	Elkay Pro Filtration® Stage 1 Sediment Prefilter	Spec Sheet (PDF)
ZGW-LORA-W1-LTE	Zurn Gateway for Connected Enabled Products	Spec Sheet (PDF)
SSBFUP-PRO	Back Panel Assembly Kit for Single Coolers with Elkay Pro Filtration Bottle Filler	Spec Sheet (PDF)
MLP100	In-wall Carrier for Single-station On-wall Bottle Fillers Coolers & Fountains	Spec Sheet (PDF)

In keeping with our policy of continuing product improvement, Elkay reserves the right to change product specifications without notice. Please visit elkay.com for the most current version of Elkay product specification sheets. This specification describes an Elkay product with design, quality, and functional benefits to the user. When making a comparison of other producers' offerings, be certain these features are not overlooked.

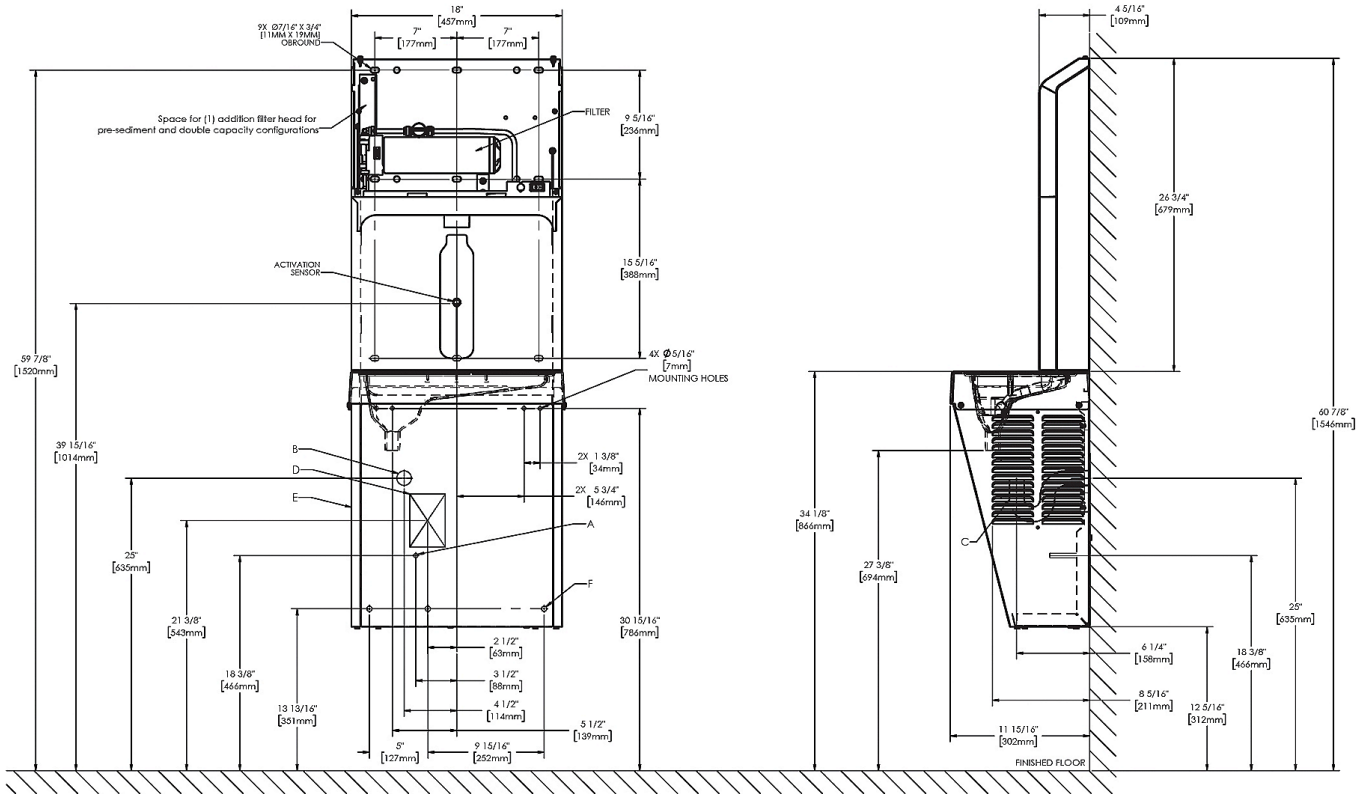

REDUCE HEIGHT BY 3 INCHES FOR INSTALLATION OF CHILDREN'S ADA COOLER

LEGEND:
 A = Recommended Water Supply location. Shut-off Valve (not furnished) to accept 3/8" O.D. unplated copper tube. Up to 3" (76mm) maximum out from wall.
 B = Recommended Waste Outlet location. To accommodate 1-1/4" nominal drain. Drain stub 2" (51mm) out from wall.
 C = 1-1/4" Trap (not furnished).
 D = Electrical Supply (3) Wire Recessed Duplex Outlet.
 E = Insure proper ventilation by maintaining 6" (152mm) minimum clearance from cabinet louvers to wall.
 F = 7/16" (11mm) Bolt Holes for fastening to wall.
 Note: New Installations Must Use Ground Fault Circuit Interrupter (GFCI).

In keeping with our policy of continuing product improvement, Elkay reserves the right to change product specifications without notice. Please visit elkay.com for the most current version of Elkay product specification sheets. This specification describes an Elkay product with design, quality, and functional benefits to the user. When making a comparison of other producers' offerings, be certain these features are not overlooked.

PRODUCT SPECIFICATIONS

Elkay Pro Filtration™ Ultra-Capacity Lead + Microplastics 10000 gal. Filter. Overall dimensions are 3-1/8" x 3-1/8" x 11-1/16".

Special Features:	Filtered
Dimensions:	3-1/8" x 3-1/8" x 11-1/16"
Shipping Weight:	2 lbs.
Flow Rate:	1.5 GPM (5.6 L/m)
Capacity:	10000 gal. (37854 L)
Temperature:	40-100°F (4-38°C)
Initial Pressure Drop:	2-5 PSI (14-34 kPa)
Maximum Pressure:	105 PSI (724 kPa)
Minimum Pressure:	20 PSI (138 kPa)
Water Inlet:	3/8" (9.5mm) O.D. tube
Water Outlet:	1/4" (6.4mm) O.D. tube

Special Note: Replacement filter exclusively for use in Elkay Pro Filtration Bottle Filling Stations

- **High-Performance System:** Pairs exclusively with Elkay Pro Filtration bottle filling stations to deliver safer drinking water
- **Certified Filtration:** Certified by IAPMO R&T to NSF/ANSI 42, 53 and 401 to reduce lead, microplastics, cysts, asbestos, turbidity, particulate class 1, chlorine, and taste and odor, and to NSF/ANSI/CAN 372 for lead free compliance
- **Ultra Capacity Filter:** Filter rated to last 10,000-gallons or up to one year after installation, resulting in fewer filter changes. Filter includes antiscalant to help prevent scale buildup and reduce maintenance costs
- **Automatic Filter Flushing:** Elkay Pro Filtration systems detect newly installed filters and automatically flush the system to make the filter ready for use within minutes of install.
- **Automatic Filter Recognition:** Elkay Pro Filtration system recognizes new filter and automatically resets filter status light, shortening installation time
- **Faster Filter Changes:** Filters are installed at the top of the unit, allowing for quick filter changes in seconds
- **Trusted Quality:** Get premier filtration from, Elkay, the industry-leading brand that's been innovating water delivery for more than 60 years



Included with Product: 10000 gallon replacement filter cartridge

A Century of Tradition and Quality.
For more than 100 years, Elkay has been making innovative products and providing exceptional customer care. We take pride in offering plumbing products that make life easier, inspire change and leave the world a better place.

Product Compliance: NSF 42
NSF 53
NSF 372 (lead free)
NSF 401



[Installation Instructions \(PDF\) - 2000001484](#)

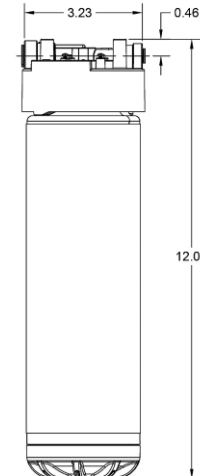
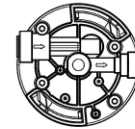

PART: _____ QTY: _____

PROJECT: _____

CONTACT: _____

DATE: _____

NOTES: _____

APPROVAL: _____

In keeping with our policy of continuing product improvement, Elkay reserves the right to change product specifications without notice. Please visit elkay.com for the most current version of Elkay product specification sheets. This specification describes an Elkay product with design, quality, and functional benefits to the user. When making a comparison of other producers' offerings, be certain these features are not overlooked.